

CATALOG #66 2025



BANJO LIQUID HANDLING PRODUCTS

2025

CATALOG #66 EFFECTIVE OCTOBER 2024





# INDEX

|                             |         |
|-----------------------------|---------|
| NEW & RETURNING             | 3-6     |
| VALVES                      | 8-19    |
| ELECTRIC VALVES             | 20-25   |
| KZVALVE                     | 26-27   |
| MANIFOLD FLANGE CONNECTIONS | 28-54   |
| DRY DISCONNECTS             | 55-65   |
| IBC/TANK ACCESSORIES        | 66-74   |
| CAM LEVER COUPLINGS         | 75-79   |
| PIPE FITTINGS               | 80-85   |
| LINE STRAINERS              | 86-97   |
| CENTRIFUGAL PUMPS           | 98-159  |
| REFERENCE                   | 160-174 |

# BECAUSE EVERY DROP COUNTS



95% **LESS** SPILLAGE, SAVING YOU MONEY



## 1" POLY DRY FIT™

### FEATURES

- Double poly-ball valves with integrated quick disconnect.
- 1" full-port (unrestricted flow)
- Allows high pressures and flow
- Economical and simpler design without handle locking feature
- 90% less spillage vs. 2 standard valves connected via a coupling.

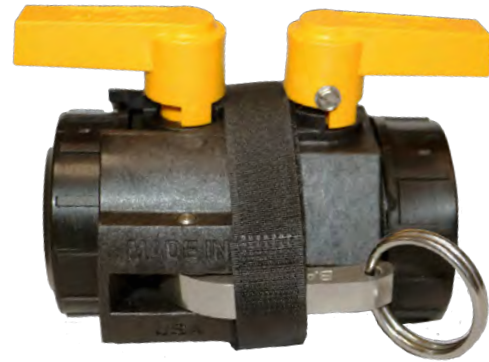

| 1" POLY DRY FIT™ |                                 |         |           |                   |     |
|------------------|---------------------------------|---------|-----------|-------------------|-----|
| PART NO          | DESCRIPTION                     | MAX PSI | PIPE SIZE | OPENING THRU BALL | QTY |
| DF100A           | 1" MALE X FPT NPT W/FKM SEALS   | 100     | 1"        | 1"                | 1   |
| DF100D           | 1" FEMALE X FPT NPT W/FKM SEALS | 100     | 1"        | 1"                | 1   |



## VALVE & REPAIR KITS & HANDLES

| PART NO   | DESCRIPTION  | QTY |
|-----------|--|-----|
| CV100V    | 1' FEMALE X FEMALE NPT CHECK                                   | 1   |
| MCV100V   | 1" MANIFOLD CHECK VALVE  | 1   |
| V10200    | KIT FOR V100FP, V125, MV100CF                                  | 1   |
| V20200    | KIT FOR V125FP, V150, V200                                     | 1   |
| V20353TS  | T HANDLE FOR V125SL, V150SL                                    | 1   |
| V25200    | KIT FOR MV220CF, V200FP, V204FP, VA200FP, VFMT200FP, VFMT204FP | 1   |
| V25200BL  | KIT FOR MV220BL, MV220SL, V200SL                               | 1   |
| V30200    | KIT FOR MV300, V300  | 1   |
| V35200    | KT FOR MV300CF, V300FP   | 1   |
| V40200    | KIT FOR V400   | 1   |
| VA200/150 | 2" FEMALE NPT X 1 1/2" NOZZLE                                  | 1   |
| VS30200   | KIT FOR MVSF300, MVSMT300, MVS300CF                            | 1   |
| VSS05200  | KIT FOR VSS050   | 1   |
| VSS10200  | KIT FOR VSS100   | 1   |
| VSS15200  | KIT FOR VSS150   | 1   |
| VSS25200  | KIT FOR VSFMT220SS, VSS200                                     | 1   |
| VSS35200  | KIT FOR VSS300   | 1   |

## PIPE FITTINGS

| PART NO    | DESCRIPTION                           | MAX PSI | LOT QTY |
|------------|---------------------------------------|---------|---------|
| CR025      | 1/4" POLY CROSS                       | 300     | 10/BAG  |
| CR038      | 3/8" POLY CROSS                       | 300     | 10/BAG  |
| HB038-025  | 3/8" MALE THREAD X 1/4" HOSE BARB     | 300     | 10/BAG  |
| HBF100-90  | 1" FEMALE THREAD X 1" 90 HOSE BARB    | 300     | 10/BAG  |
| HBT025     | 1/4" HOSE BARB TEE                    | 300     | 10/BAG  |
| HBT050-038 | 1/2" X 3/8" HOSE BARB TEE             | 300     | 10/BAG  |
| NIP400-SH  | 4" SHORT POLY NIPPLE                  | 300     | 1       |
| RB050-018  | 1/2" MNPT X 1/8" FNPT REDUCER BUSHING | 300     | 10/BAG  |
| RB100-018  | 1" MNPT X 1/8" FNPT REDUCER BUSHING   | 300     | 10/BAG  |
| RB125-038  | 1" X 3/8" FPT REDUCING BUSHING        | 300     | 10/BAG  |

## MANIFOLD

| PART NO     | DESCRIPTION                                      | MAX PSI | LOT QTY |
|-------------|--|---------|---------|
| M100125HBT  | 1" FLANGE X 1 1/4" HOSE BARB TEE                 | 300     | 10      |
| M101GSA     | 1" FULL PORT FLANGE X 1" PVC GLUE SOCKET FITTING | 300     | 10      |
| M200THB100  | 2" MANIFOLD T X 1" HOSE BARB                     | 150     | 1       |
| M201TEEV075 | 2" STANDARD VENTURI T W/ 3/4"                    | 200     | 1       |
| M220150HBT  | 1 1/2" HOSE BARB X 1 1/2" HOSE BARB              | 300     | 10      |
| M220SWP90   | 2" PULL PORT FLANGE X FLANGE SWEEP               | 300     | 10      |
| M220SWPG90  | 2" FULL PORT FLANGE X FLANGE SWEEP 1/4" PORT     | 300     | 1       |
| M221SWP90   | 2" FULL PORT MANIFOLD 90° SWEEP                  | 300     | 1       |
| MLSTM100-80 | 1" MANIFOLD MINI T STRAINER 80 MESH              | 300     | 1       |
| MLSTM100HB  | 1" MANIFOLD MINI T STRAINER HEAD & BOWL          | N/A     | 1       |
| MLSTM100HBC | 1" MANIFOLD MINI T STRAINER HEAD & CLEAR BOWL    | N/A     | 1       |
| MTF100BD    | 1" FLANGE X 1" FEMALE THREAD W/EPDM GASKET       | 300     | 10      |

## PUMPS

| PART NO    | DESCRIPTION   | HP  | QTY | SKID QTY |
|------------|---|-----|-----|----------|
| 12049F     | HYDRAULIC PEDESTAL HOUSING  | N/A | 1   | N/A      |
| 17049A     | HYDRAULIC ADAPTER   | N/A | 1   | N/A      |
| 200PIHA    | 2" CAST IRON HYDRAULIC W/O MOTOR  | N/A | 1   | N/A      |
| 333POICF   | 3" CAST IRON PUMP ONLY W/1 3/8" SHAFT & 5 VANE IMPELLER UNASSEMBLED FOR 215TC FRAME | N/A | 1   | 6        |
| BEM10-100  | 10 HP ELECTRIC MOTOR, 1" SHAFT DIAMETER 3 PHASE                                     | 10  | 1   | N/A      |
| BEM101-100 | 10 HP SINGLE PHASE WITH 1" SHAFT  | 10  | 1   | N/A      |
| BEM15      | 15 HP, 215TC, 3PH   | 15  | 1   | N/A      |
| BEM15-100  | 15 HP MOTOR WITH 1" DIAMETER SHAFT  | 15  | 1   | N/A      |
| BEM5       | CM3613T, 5HP, 184TC, 3PH  | 5   | 1   | N/A      |

## GASKETS

| PART NO | DESCRIPTION                         | HOLE SIZE | FITS POLY     | FITS SS           | LOT QTY |
|---------|-------------------------------------|-----------|---------------|-------------------|---------|
| TF100G  | 1" & 1/4" POLY BULKHEAD EPDM GASKET | 2 1/4"    | TF100 & TF125 | TF100SS & TF125SS | 25      |
| TF100GV | 1" & 1/4" POLY BULKHEAD FKM GASKET  | 2 1/4"    | TF100 & TF125 | TF100SS & TF125SS | 10      |

## 2" POLY DRY-MATES

| PART NO | DESCRIPTION                         | MAX PSI | PIPE SIZE | OPENING THRU BALL | QTY |
|---------|-------------------------------------|---------|-----------|-------------------|-----|
| DM200AT | 2" MALE X FPT NPT W/KALREZ® SEALS   | 100     | 2"        | 1 1/2"            | 1   |
| DM200DT | 2" FEMALE X FPT NPT W/KALREZ® SEALS | 100     | 2"        | 1 1/2"            | 1   |

## FEATURES

### 1 1/2" LSQ STRAINERS

| PART NO    | DESCRIPTION                           | MAX PSI | LOT QTY |
|------------|---------------------------------------|---------|---------|
| LSS300-C   | 3" STAINLESS STEEL LINE CAP           | N/A     | 1       |
| LST220SS   | 20 MESH SS SCREEN                     | N/A     | 1       |
| LSQ150-B/C | 1 1/2" X 1 1/2" LSQ STRAINER BODY/CAP | N/A     | 1       |
| LSQ200-GV  | 2" FKM GASKET                         | N/A     | 1       |



## FITTINGS WITH GAUGE PORTS

| PART NO       | DESCRIPTION   | MAX PSI | LOT QTY |
|---------------|---|---------|---------|
| M100BRBSWPG90 | 1" FULL PORT X 1" HOSE BARB WITH 1/4" GAUGE PORT        | 300     | 10/BAG  |
| M100SWPG90    | 1" FLANGE X FLANGE SWEEP WITH 1/4" GAUGE PORT           | 300     | 10/BAG  |
| M220SWP038G90 | 2" FULL PORT MANIFOLD SWEEP WITH 3/8" FNPT GAUGE PORT   | 300     | 10/BAG  |
| M220SWP050G90 | 2" FULL PORT FLANGE X FLANGE SWEEP WITH 1/2" GAUGE PORT | 300     | 10/BAG  |
| M221SWP90     | 2" FULL PORT MANIFOLD SWEEP WITH BLIND GAUGE PORT       | 300     | 1       |
| M300BRBSWPG90 | 3" HOSE BARB X FLANGE SWEEP WITH 1/4" GAUGE PORT        | 225     | 1       |
| M300SWP050G90 | 3" MANIFOLD SWEEP W/ .5" NPT PORT                       | 300     | 1       |
| M300SWPG90    | 3" FLANGE X FLANGE SWEEP WITH 1/4" GAUGE PORT           | 200     | 1       |
| M200300TEG075 | M200 X M200 X M300 WITH 3/4" THREAD PORT                | 300     | 1       |
| M200YG45      | 2" FULL PORT 45° Y FLANGE WITH GAUGE PORT               | 225     | 1       |
| M220YG45      | 2" FULL PORT 45° Y FLANGE WITH 3/4" GAUGE PORT          | 300     | 1       |
| M300YG45      | 3" FULL PORT Y FLANGE WITH 3/4 GAUGE PORT               | 200     | 1       |
| M300220WYCG   | M300 X M220 Y CROSS WITH 1/4" GAUGE PORT                | 300     | 1       |
| TEG075        | 3/4" POLY T WITH 1/4" FEMALE THREAD                     | 300     | 10/BAG  |
| TEG100        | 1" POLY TEE WITH 1/4" FEMALE THREAD                     | 300     | 10/BAG  |
| TM075/050     | 8 STATION POLY MANIFOLD                                 | 225     | 1       |

## COUPLINGS WITH GAUGE PORTS

| PART NO      | DESCRIPTION  | MAX PSI | LOT QTY |
|--------------|--|---------|---------|
| M100CPG025G  | 1" MANIFOLD COUPLING 2 1/4" PORT                         | 300     | 10/BAG  |
| M101CPG      | 1" MANIFOLD COUPLING 2 1/4" LONG W/ BLIND GAUGE PORT     | 300     | 10/BAG  |
| M200CPG025G  | 2" MANIFOLD COUPLING 4 1/2" LONG W/ 1/4" PORT            | 300     | 10/BAG  |
| M201CPG      | 2" MANIFOLD COUPLING 4 1/2" LONG W/ BLIND GAUGE PORT     | 300     | 10/BAG  |
| M220CPG2GISO | 2" FULL PORT MANIFOLD COUPLING 2" LONG W/ G 1/4" PORT    | 300     | 10/BAG  |
| M220CPG3G    | 2" FULL PORT MANIFOLD COUPLING 3" LONG W/ 1/2" PORTS (3) | 225     | 10/BAG  |
| M220CPG6025G | 2" FULL PORT MANIFOLD COUPLING 6" LONG W/ 1/4" PORTS     | 300     | 10/BAG  |
| M221CPG      | 2" FP MANIFOLD COUPLING 3" LONG W/ 3 BLIND GAUGE PORTS   | 300     | 1       |
| M221CPG6     | 2" FP MANIFOLD COUPLING 6" LONG W/ BLIND GAUGE PORT      | 300     | 10/BAG  |
| M300CPG12G   | 3" FP MANIFOLD COUPLING 12" LONG W/ 1/2" GAUGE PORT      | 150     | 1       |
| M300CPG2     | 3" FP MANIFOLD COUPLING 4" LONG W/ BLIND GAUGE PORT      | 200     | 1       |
| M300CPG55G   | 3" FULL PORT MANIFOLD COUPLING 5.5" LONG W/ 1/4" PORT    | 150     | 1       |
| M300CPG7025G | 3" MANIFOLD COUPLING 7" LONG W/ 1/4" PORT                | 300     | 1       |
| M301CPG7     | 3" MANIFOLD COUPLING 7" LONG                             | 225     | 1       |
| M300CPG2GISO | 3" MANIFOLD COUPLING 2" LONG W/ G 1/4" GAUGE PORT        | 300     | 1       |

## PLUGS WITH GAUGE PORTS

| PART NO    | DESCRIPTION                         | MAX PSI | LOT QTY |
|------------|-------------------------------------|---------|---------|
| M100PLG025 | 1" FLANGE PLUG WITH 1/4" FEMALE NPT | 300     | 10/BAG  |
| M100PLG050 | 1" FLANGE PLUG WITH 1/2" FEMALE NPT | 300     | 10/BAG  |
| M200PLG025 | 2" FLANGE PLUG WITH 1/4" FPT        | 225     | 10/BAG  |
| M200PLG038 | 2" MANIFOLD PLUG WITH 3/8" FPT      | 300     | 10/BAG  |
| M200PLG050 | 2" FLANGE PLUG WITH 1/2" FPT        | 225     | 10/BAG  |
| M200PLG075 | 2" FLANGE PLUG WITH 3/4" FPT        | 225     | 10/BAG  |
| M200PLG100 | 2" FLANGE PLUG WITH 1" FPT          | 225     | 10/BAG  |
| M220PLG038 | 2" FP MNFLD PLUG WITH 3/8" FPT      | 150     | 10/BAG  |
| M220PLG075 | 2" FP FLANGE PLUG WITH 3/4" FPT     | 225     | 10/BAG  |
| M300PLG075 | 3" FLANGE PLUG WITH 3/4" FPT        | 200     | 1       |
| M300PLG100 | 3" FLANGE PLUG WITH 1" FPT          | 200     | 1       |

# M350

**500+ GALLONS PER MINUTE  
NO LEAKS. NO WEAR. NO WORRIES  
PATENTED WET SEAL DESIGN  
ATTACHES EASILY**

More information on our M350 series is on page 122.





## EASY-FILL™ VALVES

### FEATURES

- Eliminates multiple fittings for fill applications
- Available in 2" and 3" sizes
- Full flow (full port) design
- Stubby valve configuration reduces profile
- Extended coupler prevents handle interference



| EASY-FILL™ VALVES |  |         |         |              |            |
|-------------------|--|---------|---------|--------------|------------|
| PART NO           | DESCRIPTION                                  | MAX PSI | LOT QTY | VALVE HANDLE | REPAIR KIT |
| VSBHB204FP        | 2" FULL PORT EASY-FILL™ VALVE                | 150     | 2/BOX   | VS25153      | VS25200    |
| VSBHB205FP        | 2" FULL PORT EASY-FILL™ VALVE W/CARRY HANDLE | 150     | 4/BOX   | VS25153      | VS25200    |
| VSBHB304FP        | 3" FULL PORT EASY-FILL™ VALVE                | 150     | 2/BOX   | V25153       | N/A        |
| VSBHB305FP        | 3" FULL PORT EASY-FILL™ VALVE W/CARRY HANDLE | 150     | 4/BOX   | V25153       | N/A        |
| H25053            | 2" & 3" CARRY HANDLE                         | N/A     | 1       | N/A          | N/A        |

## 1/4" -1" POLY MICRO VALVES

### FEATURES

- 90° rotating handle
- 90° locking, rotating handle (with asterisk \*)
- Precision molded polypropylene is reinforced with fiberglass for additional strength.
- Standard FKM seats and O-Rings

**JG John Guest® Fitting**  
The brand "John Guest" is a registered trademark of John Guest International Limited.

### MICRO VALVES

| PART NO    | DESCRIPTION                        | MAX PSI | THREAD SIZE | OPENING THRU BALL | LOT QTY |
|------------|------------------------------------|---------|-------------|-------------------|---------|
| LV025V     | 1/4" FEMALE NPT MICRO VALVE        | 300     | 1/4"        | 3/8"              | 10      |
| LV038V     | 3/8" FEMALE NPT MICRO VALVE        | 300     | 3/8"        | 3/8"              | 10      |
| LV050V     | 1/2" FEMALE NPT MICRO VALVE        | 300     | 1/2"        | 15/32"            | 10      |
| LV050SLV   | 1/2" SIDE LOAD MICRO VALVE         | 300     | 1/2"        | 1/2"              | 10      |
| LV050SLLV* | 1/2" SIDE LOAD LOCKING MICRO VALVE | 300     | 1/2"        | 15/32"            | 10      |

### MICRO VALVES

| PART NO  | DESCRIPTION                | MAX PSI | THREAD SIZE | OPENING THRU | LOT QTY |
|----------|----------------------------|---------|-------------|--------------|---------|
| LVBH038V | 3/8" HOSE BARB MICRO VALVE | 300     | 3/8"        | 3/8"         | 10      |
| LVBH050V | 1/2" HOSE BARB MICRO VALVE | 300     | 1/2"        | 3/8"         | 10      |
| LVBH075V | 3/4" HOSE BARB MICRO VALVE | 300     | 3/4"        | 15/32"       | 10      |

### MICRO VALVES

| PART NO       | DESCRIPTION                                     | MAX PSI | THREAD SIZE | OPENING THRU BALL | LOT QTY |
|---------------|---|---------|-------------|-------------------|---------|
| LV025MTV      | 1/4" FEMALE X MALE NPT MICRO VALVE              | 300     | 1/4"        | 3/8"              | 10      |
| LV038MTV      | 3/8" FEMALE X MALE NPT MICRO VALVE              | 300     | 3/8"        | 3/8"              | 10      |
| LV038050MTV   | 3/8" FEMALE X 1/2" MALE NPT MICRO VALVE         | 300     | 3/8" x 1/2" | 3/8"              | 10      |
| LV038050MTLV* | 3/8" FEMALE X 1/2" MALE NPT LOCKING MICRO VALVE | 300     | 3/8" x 1/2" | 3/8"              | 10      |
| LV050MTV      | 1/2" FEMALE X MALE NPT MICRO VALVE              | 300     | 1/2"        | 15/32"            | 10      |
| LV050100MTV   | 1/2" FEMALE X 1" MALE NPT MICRO VALVE           | 300     | 1/2"        | 15/32"            | 10      |
| LV050100MTLV* | 1/2" FEMALE X 1" MALE NPT LOCKING MICRO VALVE   | 300     | 1/2" x 1"   | 15/32"            | 10      |

### MICRO VALVES

| PART NO        | DESCRIPTION                                      | MAX PSI | THREAD SIZE | OPENING THRU BALL | LOT QTY |
|----------------|--|---------|-------------|-------------------|---------|
| LVBH038050MTV  | 3/8" HOSE BARB X 1/2" MALE NPT MICRO VALVE       | 300     | 1/2"        | 3/8"              | 10      |
| LVBH075MTV     | 3/4" HOSE BARB X 3/4" MALE NPT MICRO VALVE       | 300     | 3/4"        | 1/2"              | 10      |
| LVBH075100MTV  | 3/4" HOSE BARB X 1" MALE NPT MICRO VALVE         | 300     | 1"          | 15/32"            | 10      |
| LVBH075100MTLV | 3/4" HOSE BARB X 1" MALE NPT LOCKING MICRO VALVE | 300     | 1"          | 15/32"            | 10      |

### MICRO VALVES

| PART NO  | DESCRIPTION                       | MAX PSI | THREAD SIZE | OPENING THRU BALL | LOT QTY |
|----------|-----------------------------------|---------|-------------|-------------------|---------|
| LVPL025V | 1/4" FEMALE PUSH LOCK MICRO VALVE | 300     | 1/4"        | 3/8"              | 10      |
| LVPL038V | 3/8" FEMALE PUSH LOCK MICRO VALVE | 150     | 3/8"        | 3/8"              | 10      |



## ½" - 2" 4 BOLTED VALVES

### FEATURES

- FKM seals.
- Precision molded polypropylene is reinforced with fiberglass for additional strength.
- Self-aligning ball moves freely against the PTFE seats for smooth operation. The valve opens and closes with very little pressure on the handle.
- Ball is diamond turned, after molding, to make it spherically perfect, which provides precise contact between ball and seats.
- PTFE self-lubricating stem bushings and seats cannot stick or bind.
- Stainless steel bolts.

### REPAIR KIT INCLUDES:

- Ball
- Body gasket
- Thrust washer
- Ball seats
- Upper stem bushing
- Stem o-ring



| 4 BOLTED VALVES |                         |         |           |              |         |                    |            |
|-----------------|-------------------------|---------|-----------|--------------|---------|--------------------|------------|
| PART NO         | DESCRIPTION             | MAX PSI | PIPE SIZE | OPENING THRU | LOT QTY | REPLACEMENT HANDLE | REPAIR KIT |
| V050            | ½" FULL PORT VALVE      | 300     | ½"        | ¾"           | 6       | V10153A            | N/A        |
| V075            | ¾" FULL PORT VALVE      | 300     | ¾"        | ¾"           | 12      | V10153A            | N/A        |
| V100            | 1" STANDARD PORT VALVE  | 225     | 1"        | ¾"           | 12      | V10153A            | N/A        |
| V100FP          | 1" FULL PORT VALVE      | 300     | 1"        | 1"           | 12      | V10153A            | V10200     |
| V125            | 1¼" STANDARD PORT VALVE | 300     | 1¼"       | 1"           | 6       | V10153A            | V10200     |
| V125FP          | 1¼" FULL PORT VALVE     | 225     | 1¼"       | 1½"          | 6       | V20153             | V20200     |
| V150            | 1½" FULL PORT VALVE     | 225     | 1½"       | 1½"          | 6       | V20153             | V20200     |
| V200            | 2" STANDARD PORT VALVE  | 225     | 2"        | 1½"          | 12      | V20153             | V20200     |

## 2" FULL PORT 4 BOLTED BALL VALVES

### FEATURES

- FKM seals
- Stainless steel bolts
- PTFE self-lubricating stem bushings and seats cannot stick or bind
- Precision molded in fiberglass reinforced polypropylene
- Self-aligning ball moves freely against the PTFE seats for smoother operation
- Valve opens and closes with very little pressure on the handle
- Ball is diamond turned after molding to make it spherically perfect, which provides precise contact between ball and seats



| 4 BOLTED FULL PORT VALVES |  |         |           |                   |         |                    |            |
|---------------------------|--|---------|-----------|-------------------|---------|--------------------|------------|
| PART NO                   | DESCRIPTION                                | MAX PSI | PIPE SIZE | OPENING THRU BALL | LOT QTY | REPLACEMENT HANDLE | REPAIR KIT |
| VFMT204FP                 | 2" FULL PORT VALVE MALE NPT X MALE ADAPTER | 150     | 2"        | 2"                | 6/BOX   | V25153             | V25200     |
| V204FP                    | 2" FULL PORT VALVE                         | 150     | 2"        | 2"                | 8/BOX   | V25153             | V25200     |

## 2"-4" 6 BOLTED VALVES

### FEATURES

- FKM seals.
- Precision molded polypropylene is reinforced with fiberglass for additional strength.
- Self-aligning ball moves freely against the PTFE seats for smooth operation. The valve opens and closes with very little pressure on the handle.
- Ball is diamond turned, after molding, to make it spherically perfect, which provides precise contact between ball and seats.
- PTFE self-lubricating stem bushings and seats cannot stick or bind.
- Stainless steel bolts.

### REPAIR KIT INCLUDES:

- Ball
- Body gasket
- Thrust washer
- Ball seats
- Upper stem bushing
- Stem o-ring



| 6 BOLTED VALVES |                                 |         |           |                   |         |                    |            |
|-----------------|---------------------------------|---------|-----------|-------------------|---------|--------------------|------------|
| PART NO         | DESCRIPTION                     | MAX PSI | PIPE SIZE | OPENING THRU BALL | LOT QTY | REPLACEMENT HANDLE | REPAIR KIT |
| V200FP          | 2" FULL PORT VALVE              | 225     | 2"        | 2"                | 8/BOX   | V25153             | V25200     |
| VFMT200FP       | 2" FULL PORT VALVE W/ F ADAPTER | 225     | 2"        | 2"                | 6/BOX   | V25153             | V25200     |
| V300            | 3" STANDARD PORT VALVE          | 225     | 3"        | 2½"               | 8/BOX   | V25153             | V30200     |
| V300FP          | 3" FULL PORT VALVE              | 200     | 3"        | 3"                | 6/BOX   | V25153             | V35200     |
| V400            | 4" STANDARD PORT VALVE          | 100     | 4"        | 3½"               | 1       | V25153             | V40200     |

## 2" FULL PORT ANSI FLANGE BOLTED BALL VALVES

### FEATURES

- 100% PTFE seats
- FKM seals
- Glass-filled polypropylene
- Unique compact design
- Lightweight
- Gaskets featured on page 74

### REPAIR KIT INCLUDES:

- Ball
- Body gasket
- Thrust washer
- Ball seats
- Upper stem bushing
- Stem o-ring

### FULL PORT ANSI FLANGE BOLTED VALVES

| PART NO    | DESCRIPTION                                      | MAX PSI | PIPE SIZE | OPENING THRU BALL | LOT QTY | REPLACEMENT HANDLE | REPAIR KIT |
|------------|--|---------|-----------|-------------------|---------|--------------------|------------|
| VSF200PPAF | 2" FULL PORT VALVE MALE ADAPTER X 2" ANSI FLANGE | 200     | 2"        | 2"                | 6/BOX   | V25153SH           | VS25200    |





VALVE ACCESSORIES

FEATURES

- 304 stainless steel construction
- Installs under valve handle
- Comes complete with handle and locking device
- Padlock not included



| VALVE ACCESSORIES |                                 |                         |         |
|-------------------|---------------------------------|-------------------------|---------|
| PART NO           | DESCRIPTION                     | FITS VALVES             | LOT QTY |
| V10200            | VALVE REPAIR KIT 1" FP & 1 1/4" | V100FP, V125M MV100CF   | 1       |
| V10270            | STRAIGHT MOUNTING BRACKET       | V100FP, V125            | 1       |
| V10271            | 90° MOUNTING BRACKET            | V100FP, V125            | 1       |
| VL20153           | LOCKING DEVICE                  | V125, V150, V200        | 1       |
| V25270            | STRAIGHT MOUNTING BRACKET       | V125FP, V150, V200      | 1       |
| V25271            | 90° MOUNTING BRACKET            | V125FP, V150, V200      | 1       |
| V10153138         | 1" X 1 3/8" HANDLE OFFSET       | V100FP, V125            | 1       |
| V20153138         | 2" X 1 3/8" HANDLE OFFSET       | V125FP, V150, V200      | 10      |
| V25153138         | 2" FP X 1 3/8" HANDLE OFFSET    | V200FP                  | 1       |
| V10153138BL       | 1" X 1 3/8" BL HANDLE OFFSET    | V100BL, MV100BL         | 1       |
| V20153138BL       | 2" X 1 3/8" BL HANDLE OFFSET    | V125BL, V150BL, MV200BL | 10      |
| V25153138BL       | 2" FP X 1 3/8" BL HANDLE OFFSET | V200BL, MV220BL         | 1       |

VALVE ACCESSORIES

FEATURES

- Stainless steel hardware
- Locks in open and closed positions
- Locking handle replaces standard handle (sold separately)
- Padlock not included



| VALVE ACCESSORIES |                           |                                       |     |
|-------------------|---------------------------|---------------------------------------|-----|
| PART NO           | DESCRIPTION               | FITS VALVES                           | QTY |
| VL25153           | LOCKING HANDLE            | V200FP, V300, V300FP, V400, VFMT200FP | 1   |
| V25270            | STRAIGHT MOUNTING BRACKET | V200FP, V300, V300FP, V400, VFMT200FP | 1   |
| V25271            | 90° MOUNTING BRACKET      | V200FP, V300, V300FP, V400, VFMT200FP | 1   |



| 2" STANDARD PORT STUBBY VALVES |                                 |         |           |                   |         |                    |            |
|--------------------------------|---------------------------------|---------|-----------|-------------------|---------|--------------------|------------|
| PART NO                        | DESCRIPTION                     | MAX PSI | PIPE SIZE | OPENING THRU BALL | LOT QTY | REPLACEMENT HANDLE | REPAIR KIT |
| VSF200                         | 2" MALE ADAPTER X 2" FEMALE NPT | 100     | 2"        | 1 1/2"            | 6       | VS20152SH          | VS20200    |
| VSMT200                        | 2" MALE NPT X 2" FEMALE NPT     | 100     | 2"        | 1 1/2"            | 6       | VS20152SH          | VS20200    |
| VSFMT200                       | 2" MALE ADAPTER X 2" MALE NPT   | 225     | 2"        | 1 1/2"            | 12      | VS20152SH          | VS20200    |
| VSFHB200                       | 2" MALE ADAPTER X 2" HOSE BARB  | 100     | 2"        | 1 1/2"            | 6       | VS20152SH          | VS20200    |

2" STANDARD PORT STUBBY BALL VALVES

FEATURES

- Stainless steel bolts
- Glass reinforced polypropylene
- Multiple design options
- Unique patented compact design
- Lightweight
- All PTFE seals



| 2" FULL PORT STUBBY STAINLESS STEEL VALVE |   |         |           |                   |     |                    |            |
|---|---|---------|-----------|-------------------|-----|--------------------|------------|
| PART NO                                   | DESCRIPTION   | MAX PSI | PIPE SIZE | OPENING THRU BALL | QTY | REPLACEMENT HANDLE | REPAIR KIT |
| VSFMT220SS                                | 2" FULL PORT STUBBY SS VALVE MALE THREAD X MALE ADAPTER | 225     | 2"        | 2"                | 1   | VSS20153           | VSS25200   |

2" FP STUBBY STAINLESS STEEL VALVE

FEATURES

- PTFE seals, no elastomers
- Self-aligning ball moves freely against the PTFE seats for smooth operation. The valve opens and closes with very little pressure on the handle
- PTFE self-lubricating stem bushings and seats cannot stick or bind



# VALVES

## 2" FULL PORT STUBBY BALL VALVES

### FEATURES

- Stainless steel bolts
- 100% PTFE ball seats
- Glass reinforced polypropylene
- Unique patented compact design
- Lightweight
- FKM body seals

### REPAIR KIT INCLUDES:

- Ball
- Body gasket
- Thrust washer
- Ball seats
- Upper stem bushing
- Stem o-ring



VSMT204FP



VSF204FP



VS204FP



VSFMT204FP



VSFMT204HSFP

### 2" FULL PORT STUBBY VALVES

| PART NO      | DESCRIPTION  | MAX PSI | PIPE SIZE | OPENING THRU BALL | LOT QTY | REPLACEMENT HANDLE | REPAIR KIT |
|--------------|--|---------|-----------|-------------------|---------|--------------------|------------|
| VSMT204FP    | 2" MALE NPT X 2" FEMALE NPT                                | 200     | 2"        | 2"                | 6       | VS25153            | VS25200    |
| VSF204FP     | 2" MALE ADAPTER X 2" FEMALE NPT                            | 100     | 2"        | 2"                | 6       | VS25153            | VS25200    |
| VS204FP      | 2" FEMALE NPT X 2" FEMALE NPT                              | 225     | 2"        | 2"                | 6       | VS25153            | VS25200    |
| VSFMT204FP   | 2" MALE ADAPTER X 2" MALE NPT                              | 150     | 2"        | 2"                | 6       | VS25153            | VS25200    |
| VSFMT204HSFP | 2" FP MALE ADAPTER X 2" MALE NPT W/ SS BALL, STEM & HANDLE | 150     | 2"        | 2"                | 6       | N/A                | VSSH25200  |



VSF300



VSMT300



VSFMT300

### 3" STANDARD PORT STUBBY VALVES

| PART NO  | DESCRIPTION                     | MAX PSI | PIPE SIZE | OPENING THRU BALL | LOT QTY | REPLACEMENT HANDLE STRAIGHT | REPLACEMENT HANDLE SHORT | REPAIR KIT |
|----------|---------------------------------|---------|-----------|-------------------|---------|-----------------------------|--------------------------|------------|
| VSF300   | 3" FEMALE NPT X 3" MALE ADAPTER | 100     | 3"        | 2½"               | 6/BOX   | V25153                      | V25153SH                 | VS30200    |
| VSMT300  | 3" FEMALE NPT X 3" MALE NPT     | 100     | 3"        | 2½"               | 6/BOX   | V25153                      | V25153SH                 | VS30200    |
| VSFMT300 | 3" MALE NPT X 3" MALE ADAPTER   | 225     | 3"        | 2½"               | 6/BOX   | V25153                      | V25153SH                 | VS30200    |



VSFMT300FP



VSFMT300HSFP

### 3" FULL PORT STUBBY VALVES

| PART NO      | DESCRIPTION  | MAX PSI | PIPE SIZE | OPENING THRU BALL | LOT QTY | REPLACEMENT HANDLE | REPAIR KIT |
|--------------|--|---------|-----------|-------------------|---------|--------------------|------------|
| VSFMT300FP   | 3" FULL PORT MALE ADAPTER X 3" MALE NPT                          | 100     | 3"        | 3"                | 6/BOX   | V25153             | VS35200    |
| VSFMT300HSFP | 3" FULL PORT MALE ADAPTER X 3" MALE NPT W/SS BALL, STEM & HANDLE | 100     | 3"        | 3"                | 6/BOX   | VS30153SS          | N/A        |

## 3" STANDARD PORT STUBBY BALL VALVES

### FEATURES

- Stainless steel bolts
- Glass reinforced polypropylene
- FKM body seals
- Unique patented compact design
- Lightweight
- All PTFE seats
- Note: If repair kits not listed, components available.

## 3" FULL PORT STUBBY BALL VALVES

### FEATURES

- Stainless steel bolts
- Glass reinforced polypropylene
- FKM body seals
- Unique patented compact design
- Lightweight
- All PTFE ball seats
- Note: If repair kits not listed, components available.



## 3 WAY BOTTOM LOAD BALL VALVES

### FEATURES

- Stainless steel bolts
- Precision molded in fiberglass reinforced polypropylene for additional strength
- Self-aligning ball moves freely against the PTFE seats for smooth operation
- Ball is diamond turned after molding to make it spherically perfect, which provides precise contact between ball and seats
- PTFE self-lubricating stem bushings and seats
- FKM body seals
- Directional flow, right or left. Valve can be turned off to stop flow



| 3 WAY BOTTOM LOAD VALVES |                                   |         |           |                   |         |             |                    |            |
|--------------------------|-----------------------------------|---------|-----------|-------------------|---------|-------------|--------------------|------------|
| PART NO                  | DESCRIPTION                       | MAX PSI | PIPE SIZE | OPENING THRU BALL | LOT QTY | HANDLE TYPE | REPLACEMENT HANDLE | REPAIR KIT |
| V075BL                   | 3/4" 3-WAY BOTTOM LOAD VALVE      | 200     | 3/4"      | 1"                | 6       | T           | V10353TB           | N/A        |
| V100BL                   | 1" FP 3-WAY BOTTOM LOAD VALVE     | 225     | 1"        | 1"                | 6       | T           | V10353TB           | N/A        |
| V125BL                   | 1 1/4" 3-WAY BOTTOM LOAD VALVE    | 300     | 1 1/4"    | 1 1/2"            | 6       | T           | V20353TB           | N/A        |
| V150BL                   | 1 1/2" FP 3-WAY BOTTOM LOAD VALVE | 225     | 1 1/2"    | 1 1/2"            | 6       | T           | V20353TB           | N/A        |
| V200BL                   | 2" FP 3-WAY BOTTOM LOAD VALVE     | 200     | 2"        | 2"                | 8/BOX   | STRAIGHT    | V25353B            | V25200BL   |

## 3 WAY SIDE LOAD BALL VALVES

### FEATURES

- Stainless steel bolts
- Precision molded in fiberglass reinforced polypropylene for additional strength
- Self-aligning ball moves freely against the PTFE seats for smooth operation
- Ball is diamond turned after molding to make it spherically perfect, which provides precise contact between ball and seats
- PTFE self-lubricating stem bushings and seats
- FKM body seals
- Directional flow, right or left. Valve cannot be turned off to stop flow



| 3 WAY SIDE LOAD VALVES |                                 |         |           |                   |         |             |                    |            |
|------------------------|---------------------------------|---------|-----------|-------------------|---------|-------------|--------------------|------------|
| PART NO                | DESCRIPTION                     | MAX PSI | PIPE SIZE | OPENING THRU BALL | LOT QTY | HANDLE TYPE | REPLACEMENT HANDLE | REPAIR KIT |
| V075SL                 | 3/4" 3-WAY SIDE LOAD VALVE      | 200     | 3/4"      | 1"                | 6       | STRAIGHT    | V10153A            | N/A        |
| V100SL                 | 1" FP 3-WAY SIDE LOAD VALVE     | 200     | 1"        | 1"                | 6       | STRAIGHT    | V10153A            | N/A        |
| V125SL                 | 1 1/4" 3-WAY SIDE LOAD VALVE    | 300     | 1 1/4"    | 1 1/2"            | 6       | T           | V20353TS           | N/A        |
| V150SL                 | 1 1/2" FP 3-WAY SIDE LOAD VALVE | 225     | 1 1/2"    | 1 1/2"            | 6       | T           | V20353TS           | N/A        |
| V200SL                 | 2" FP 3-WAY SIDE LOAD VALVE     | 225     | 2"        | 2"                | 8/BOX   | STRAIGHT    | V25153SH           | V25200BL   |

## 1 1/2" - 2" NOZZLE VALVES

### FEATURES

- Lightweight hose end valve for convenient transfer of liquids into drums, tanks etc
- Angled end flange with 8" long polypropylene fill spout
- All stainless steel bolts



| 1 1/2"-2" NOZZLE VALVES |                                    |         |             |                   |            |         |                    |                    |            |
|-------------------------|------------------------------------|---------|-------------|-------------------|------------|---------|--------------------|--------------------|------------|
| PART NO                 | DESCRIPTION                        | MAX PSI | PIPE SIZE   | OPENING THRU BALL | FEMALE NPT | LOT QTY | REPLACEMENT HANDLE | REPLACEMENT NOZZLE | REPAIR KIT |
| VA150                   | 1 1/2" NOZZLE VALVE WITH 90° ELBOW | 225     | 1 1/2" x 8" | 1 1/2"            | 1 1/2"     | 6       | V20152             | V20166             | V20200     |
| VA200                   | 2" NOZZLE VALVE WITH 90° ELBOW     | 200     | 2" x 8"     | 1 1/2"            | 2"         | 6       | V20152             | V25156             | V20200     |
| VA200/150               | 2" FEMALE NPT X 1 1/2" NOZZLE      | 200     |             | 1 1/2"            | 1 1/2"     | 1       | V20152             | V25156             | V20200     |
| VA200FP                 | 2" FP NOZZLE VALVE WITH 90° ELBOW  | 225     | 2" x 8"     | 2"                | 2"         | 6/BOX   | V25152             | V25156             | V25200     |

## 1" DISPENSING NOZZLES

### FEATURES

- Glass reinforced polypropylene
- 304 stainless steel handle, spring and pin
- FKM rubber parts only
- Resists corrosion



| 1" DISPENSING NOZZLE |   |         |           |     |            |
|----------------------|---|---------|-----------|-----|------------|
| PART NO              | DESCRIPTION   | MAX PSI | PIPE SIZE | QTY | REPAIR KIT |
| VN100                | 1" DISPENSING NOZZLE  | 150     | 1"        | 1   | VN10200    |
| V10161               | 1" NOZZLE PIPE FOR USE WITH V100, V100FP, UV100FP, SUV100FP | 150     | 1"        | 1   | N/A        |



# VALVES

## 1/2" - 2" SINGLE UNION SPINWELD VALVES

### FEATURES

- Precision molded in glass reinforced polypropylene for strength and chemical resistance
- PTFE seats for smooth and proper sealing characteristics
- EPDM O-rings to handle most fertilizers and many chemicals
- Double O-rings in stem area for extra sealing protection
- Interlocking body and end plate to allow easy thread connection when installing valves
- Replacement parts not available



SUV125FP

MSUV100FP

### 1/2"-2" SINGLE UNION SPINWELD VALVES

| PART NO   | DESCRIPTION                                       | MAX PSI | PIPE SIZE | OPENING THRU BALL | LOT QTY |
|-----------|---|---------|-----------|-------------------|---------|
| SUV050FP  | 1/2" FULL PORT SINGLE UNION SPINWELD VALVE        | 300     | 1/2"      | 1/2"              | 10      |
| SUV075FP  | 3/4" FULL PORT SINGLE UNION SPINWELD VALVE        | 300     | 3/4"      | 3/4"              | 10      |
| SUV100FP  | 1" FULL PORT SINGLE UNION SPINWELD VALVE          | 300     | 1"        | 1"                | 10      |
| SUV125FP  | 1 1/4" FULL PORT SINGLE UNION SPINWELD VALVE      | 300     | 1 1/4"    | 1 1/4"            | 10      |
| SUV150FP  | 1 1/2" FULL PORT SINGLE UNION SPINWELD VALVE      | 300     | 1 1/2"    | 1 1/2"            | 10      |
| SUV200FP  | 2" FULL PORT SINGLE UNION SPINWELD VALVE          | 200     | 2"        | 2"                | 10      |
| MSUV100FP | 1" MANIFOLD FULL PORT SINGLE UNION SPINWELD VALVE | 300     | 1"        | 1"                | 10      |

## 1/2" - 2" SINGLE UNION VALVES

### FEATURES

- Precision molded in glass reinforced polypropylene for strength and chemical resistance
- PTFE seats for smooth and proper sealing characteristics
- Double O-rings in stem area for extra sealing protection
- Interlocking body and end plate to allow easy thread connection when installing valves
- Replacement parts not available



### 1/2"-2" SINGLE UNION VALVES

| PART NO | DESCRIPTION                         | MAX PSI | PIPE SIZE | OPENING THRU BALL | LOT QTY |
|---------|-------------------------------------|---------|-----------|-------------------|---------|
| UV050FP | 1/2" FULL PORT SINGLE UNION VALVE   | 300     | 1/2"      | 3/4"              | 10      |
| UV075FP | 3/4" FULL PORT SINGLE UNION VALVE   | 300     | 3/4"      | 3/4"              | 10      |
| UV100FP | 1" FULL PORT SINGLE UNION VALVE     | 300     | 1"        | 1"                | 10      |
| UV125FP | 1 1/4" FULL PORT SINGLE UNION VALVE | 225     | 1 1/4"    | 1 1/4"            | 10      |
| UV150FP | 1 1/2" FULL PORT SINGLE UNION VALVE | 200     | 1 1/2"    | 1 1/2"            | 10      |
| UV200FP | 2" FULL PORT SINGLE UNION VALVE     | 300     | 2"        | 2"                | 10      |

## 1/2" - 3" CHECK VALVES

### FEATURES

- One piece construction
- Glass reinforced polypropylene
- 316 stainless steel springs
- EPDM gasket



### 1/2"-3" CHECK VALVES

| PART NO | DESCRIPTION                      | CRACKING PRESSURE PSI | MAX PSI | PIPE SIZE | LOT QTY |
|---------|----------------------------------|-----------------------|---------|-----------|---------|
| CV050   | 1/2" CHECK VALVE                 | 6-7                   | 300     | 1/2"      | 10      |
| CV100   | 1" CHECK VALVE                   | 1                     | 300     | 1"        | 10      |
| CV100MT | 1" MALE X FEMALE NPT CHECK VALVE | 1                     | 300     | 1"        | 10      |
| CV100V  | 1" FEMALE X FEMALE NPT CHECK     | 1                     | 300     | 1"        | 1       |
| CV221   | 2" FULL PORT CHECK VALVE         | >0.5                  | 300     | 2"        | 10      |
| CV300   | 3" FULL PORT CHECK VALVE         | 1.5                   | 300     | 3"        | 1       |
| CV301   | 3" FULL PORT CHECK VALVE         | >0.5                  | 300     | 3"        | 1       |



### 1/4"-3" STAINLESS STEEL FULL PORT VALVES

| PART NO | DESCRIPTION               | MAX PSI | PIPE SIZE | OPENING THRU BALL | QTY | REPAIR KIT | REPLACEMENT HANDLE |
|---------|---------------------------|---------|-----------|-------------------|-----|------------|--------------------|
| VSS025  | 1/4" SS FULL PORT VALVE   | 1000    | 1/4"      | 1/4"              | 1   | VSS02500   | VSS05153           |
| VSS038  | 3/8" SS FULL PORT VALVE   | 1000    | 3/8"      | 3/8"              | 1   | VSS02500   | VSS05153           |
| VSS050  | 1/2" SS FULL PORT VALVE   | 1000    | 1/2"      | 1/2"              | 1   | VSS05200   | VSS05153           |
| VSS075  | 3/4" SS FULL PORT VALVE   | 1000    | 3/4"      | 3/4"              | 1   | VSS07200   | VSS07153           |
| VSS100  | 1" SS FULL PORT VALVE     | 1000    | 1"        | 1"                | 1   | VSS10200   | VSS10153           |
| VSS150  | 1 1/2" SS FULL PORT VALVE | 1000    | 1 1/2"    | 1 1/2"            | 1   | VSS15200   | N/A                |
| VSS200  | 2" SS FULL PORT VALVE     | 1000    | 2"        | 2"                | 1   | VSS25200   | VSS20153           |
| VSS300  | 3" SS FULL PORT VALVE     | 1000    | 3"        | 3"                | 1   | VSS35200   | N/A                |

## 3/4" - 1" PINCH VALVES

- Open position allows full unobstructed flow of 50-60 GPM
- Air pressure collapses the internal rubber sleeve to provide positive shut off
- Standard EPDM rubber bladder seal and FKM available
- Female NPT threads
- ATTENTION: Normally an open valve and has a maximum liquid pressure of 70 PSI. Pressure differential = pressure it takes to close valve

### 3/4"-1" PINCH VALVES

| PART NO    | DESCRIPTION             | GASKET | MAX PSI | PIPE SIZE | PRESSURE DIFFERENTIAL | LOT QTY |
|------------|-------------------------|--------|---------|-----------|-----------------------|---------|
| PV075      | 3/4" X 3/4" PINCH VALVE | EPDM   | 300     | 3/4"      | 15 TO 20 PSI          | 10      |
| PV100      | 1" X 1" PINCH VALVE     | EPDM   | 300     | 1"        | 15 TO 20 PSI          | 1       |
| PV100-075  | 1" X 3/4" PINCH VALVE   | EPDM   | 300     | 1" X 3/4" | 15 TO 20 PSI          | 10      |
| PV100-075V | 1" X 3/4" PINCH VALVE   | FKM    | 300     | 1" X 3/4" | 15 TO 20 PSI          | 1       |
| PV10265    | BLADDER FOR PINCH VALVE | EPDM   | N/A     | N/A       | N/A                   | 1       |
| PV10265V   | BLADDER FOR PINCH VALVE | FKM    | N/A     | N/A       | N/A                   | 1       |





**SMALLER**

- EVX 2" full port and 3" models are over 35% smaller than the average competitive valve. The 1½", 2" full port and 3" models are also substantially lighter than the average competitive valve.

**SMARTER**

- EVX offers many protocol options for your needs:
  - On/Off
  - Regulating
  - Regulating with linear feedback
  - CAN/ISO BUS
  - Proportional control
- Diagnostic options for CANBUS
  - Voltage
  - Temperature
  - Cycle Count

**TOUGHER**

- Setting the new standard for electric valve toughness, EVX passes 52 separate durability torture tests including mechanical shock, vibration, extreme temperature, rain/shine, operating pressure, and rigorous longevity tests.



**SMALLER / SMARTER / TOUGHER**

**¾" - 1½" EVX SERIES**

**FEATURES**

- 12-volt DC operated
- 24-volt available
- Open/closed indicator
- ¾"-1¼" ON/OFF has ¼ sec response
- 1½" ON/OFF has ½ sec response
- Regulating has 4 sec response
- Open/Close verification wires available
- IP68 waterproof
- -0 to 150F (-18 to 65C) operating
- -67 to 221F (-55 to 105C) storage
- On/Off Actuator rated to 500,000 cycles
- Regulating Actuator rated to 250,000 cycles
- Valve rated to 50,000 cycles leak-free
- Bolted valves have the same exact dimensions as our legacy EV valves.
- Additional protocols available including CAN/ISO BUS

**MATERIALS**

- 316 stainless steel ball & stem
- Stainless steel hardware
- Fiberglass reinforced polypropylene
- PTFE seats
- FKM stem seals

**ON/OFF**

- Red = +12V DC
- Black = Ground
- White = +12VDC (Open)  
0VDC (Close)

**4 WIRE REGULATING**

- Red = +12V DC (Open)
- White = Ground (Open)
- Black = +12V DC (Close)
- Green = Ground (Close)



| ¾" - 1½" EVX ON/OFF BOLTED ELECTRIC VALVES |                                  |         |           |                   |     |                     |            |
|--|----------------------------------|---------|-----------|-------------------|-----|---------------------|------------|
| PART NO                                    | DESCRIPTION                      | MAX PSI | PIPE SIZE | OPENING THRU BALL | QTY | OPTIONAL HANDLE KIT | REPAIR KIT |
| EVX071                                     | ¾" FULL PORT ELECTRIC VALVE      | 300     | ¾"        | 1"                | 1   | VP20153SH           | EVX10200   |
| EVX101                                     | 1" FULL PORT ELECTRIC VALVE      | 300     | 1"        | 1"                | 1   | VP20153SH           | EVX10200   |
| EVX121                                     | 1¼" STANDARD PORT ELECTRIC VALVE | 300     | 1¼"       | 1"                | 1   | VP20153SH           | EVX10200   |
| EVX151                                     | 1½" FULL PORT ELECTRIC VALVE     | 250     | 1½"       | 1½"               | 1   | VP20153SH           | EVX20200   |

| ¾" - 1½" EVX REGULATING BOLTED ELECTRIC VALVES |                              |         |           |                   |     |                     |            |
|--|------------------------------|---------|-----------|-------------------|-----|---------------------|------------|
| PART NO  | DESCRIPTION                  | MAX PSI | PIPE SIZE | OPENING THRU BALL | QTY | OPTIONAL HANDLE KIT | REPAIR KIT |
| EVXR071  | ¾" FULL PORT ELECTRIC VALVE  | 300     | ¾"        | 1"                | 1   | VP20153SH           | EVX10200   |
| EVXR101  | 1" FULL PORT ELECTRIC VALVE  | 300     | 1"        | 1"                | 1   | VP20153SH           | EVX10200   |
| EVXR151  | 1½" FULL PORT ELECTRIC VALVE | 250     | 1½"       | 1½"               | 1   | VP20153SH           | EVX20200   |



## 2" EVX SERIES

## 3" EVX SERIES

### FEATURES

### FEATURES

- 12-volt DC operated
- 24-volt available
- Open/closed indicator
- ON/OFF has 1½ second response
- Regulating has 4 second response
- Open/Close verification wires available
- IP68 waterproof
- -0 to 150F (-18 to 65C) operating
- -67 to 221F (-55 to 105C) storage
- On/Off Actuator rated to 500,000 cycles
- Regulating Actuator rated to 250,000 cycles
- Valve rated to 50,000 cycles leak-free
- Bolted valves have the same exact dimensions as our legacy EV valves.
- Additional protocols available including CAN/ISO BUS

- 12-volt DC operated
- 24-volt available
- Open/closed indicator
- ON/OFF has 4 second response
- Regulating has 4 second response
- Open / Close verification available
- IP68 waterproof
- -0 to 150F (-18 to 65C) operating
- -67 to 221F (-55 to 105C) storage
- Actuator rated to 250,000 cycles
- Valve rated to 50,000 cycles leak-free
- Additional protocols available including CAN/ISO BUS

### MATERIALS

### MATERIALS

- 316 stainless steel ball & stem
- Stainless steel hardware
- Fiberglass reinforced polypropylene
- PTFE seats
- FKM stem seals

- 316 stainless steel ball & stem
- Stainless steel hardware
- Fiberglass reinforced polypropylene
- Zinc alloy lower actuator housing
- PTFE seats
- FKM stem seals

### ON/OFF

### ON/OFF

- Red = +12V DC
- Black = Ground
- White = +12VDC (Open)  
0VDC (Close)

- Red = +12V DC
- Black = Ground
- White = +12VDC (Open)  
0VDC (Close)

### 4 WIRE REGULATING

### 4 WIRE REGULATING

- Red = +12V DC (Open)
- White = Ground (Open)
- Black = +12V DC (Close)
- Green = Ground (Close)

- Red = +12V DC (Open)
- White = Ground (Open)
- Black = +12V DC (Close)
- Green = Ground (Close)



### 2" EVX ON/OFF BOLTED ELECTRIC VALVES

| PART NO | DESCRIPTION                     | MAX PSI | PIPE SIZE | OPENING THRU BALL | QTY | OPTIONAL HANDLE KIT | REPAIR KIT |
|---------|---------------------------------|---------|-----------|-------------------|-----|---------------------|------------|
| EVX201  | 2" STANDARD PORT ELECTRIC VALVE | 250     | 2"        | 1½"               | 1   | VP20153             | EVX20200   |
| EVX221  | 2" FULL PORT ELECTRIC VALVE     | 125     | 2"        | 2"                | 1   | VP20153             | EVX25200   |

### 3" EVX ON/OFF ELECTRIC VALVES

| PART NO | DESCRIPTION                 | MAX PSI | PIPE SIZE | OPENING THRU BALL | QTY | OPTIONAL HANDLE KIT |
|---------|-----------------------------|---------|-----------|-------------------|-----|---------------------|
| EVX300  | 3" FULL PORT ELECTRIC VALVE | 125     | 3"        | 3"                | 1   | VP30153             |

### 2" EVX REGULATING BOLTED ELECTRIC VALVES

| PART NO | DESCRIPTION                     | MAX PSI | PIPE SIZE | OPENING THRU BALL | QTY | OPTIONAL HANDLE KIT | REPAIR KIT |
|---------|---------------------------------|---------|-----------|-------------------|-----|---------------------|------------|
| EVXR201 | 2" STANDARD PORT ELECTRIC VALVE | 250     | 2"        | 1½"               | 1   | VP20153             | EVX20200   |
| EVXR221 | 2" FULL PORT ELECTRIC VALVE     | 125     | 2"        | 2"                | 1   | VP20153             | EVX25200   |

### 3" EVX REGULATING ELECTRIC VALVES

| PART NO | DESCRIPTION                 | MAX PSI | PIPE SIZE | OPENING THRU BALL | QTY | OPTIONAL HANDLE KIT |
|---------|-----------------------------|---------|-----------|-------------------|-----|---------------------|
| EVXR300 | 3" FULL PORT ELECTRIC VALVE | 125     | 3"        | 3"                | 1   | VP30153             |



## 3/4" - 2" EVX SERIES BOTTOM & SIDE LOAD VALVES

### FEATURES

- 12-volt DC operated
- 24-volt available
- Open/closed indicator
- 1" & 1 1/4" ON/OFF has 3/4 second response
- 1 1/2" & 2" ON/OFF has 1 1/2" second response
- Open / Close verification available
- IP68 waterproof
- -0 to 150F (-18 to 65C) operating
- -67 to 221F (-55 to 105C) storage
- On/Off Actuator rated to 500,000 cycles
- Valve rated to 50,000 cycles leak-free
- These bolted valves have the exact same dimensions as our legacy EV valves.
- Additional protocols available including CAN/ISO BUS

### MATERIALS

- 316 stainless steel ball & stem
- Stainless steel hardware
- Fiberglass reinforced polypropylene
- PTFE seats
- FKM stem seals

### ON/OFF

- Red = +12V DC
- Black = Ground
- White = +12VDC (Open)  
0VDC (Close)

### 4 WIRE REGULATING

- Red = +12V DC (Open)
- White = Ground (Open)
- Black = +12V DC (Close)
- Green = Ground (Close)



### 3/4"-2" EVX BOLTED BOTTOM LOAD ELECTRIC VALVES

| PART NO  | DESCRIPTION                                 | MAX PSI | PIPE SIZE | OPENING THRU BALL | QTY | OPTIONAL HANDLE KIT | REPAIR KIT |
|----------|---|---------|-----------|-------------------|-----|---------------------|------------|
| EVX075BL | 3/4" FULL PORT BOTTOM LOAD ELECTRIC VALVE   | 300     | 3/4"      | 1"                | 1   | VP20153SH           | EVX10200   |
| EVX100BL | 1" FULL PORT BOTTOM LOAD ELECTRIC VALVE     | 300     | 1"        | 1"                | 1   | VP20153SH           | EVX10200   |
| EVX125BL | 1 1/4" FULL PORT SIDE LOAD ELECTRIC VALVE   | 250     | 1 1/4"    | 1"                | 1   | VP20153SH           | EVX10200   |
| EVX150BL | 1 1/2" FULL PORT SIDE LOAD ELECTRIC VALVE   | 250     | 1 1/2"    | 1 1/2"            | 1   | VP20153SH           | EVX20200   |
| EVX200BL | 2" STANDARD PORT BOTTOM LOAD ELECTRIC VALVE | 250     | 2"        | 1 1/2"            | 1   | VP20153             | EVX20200   |
| EVX220BL | 2" FULL PORT BOTTOM LOAD ELECTRIC VALVE     | 125     | 2"        | 2"                | 1   | VP20153             | EVX25200   |

### 3/4"-2" EVX BOLTED SIDE LOAD ELECTRIC VALVES

| PART NO  | DESCRIPTION                               | MAX PSI | PIPE SIZE | OPENING THRU BALL | QTY | OPTIONAL HANDLE KIT | REPAIR KIT |
|----------|---|---------|-----------|-------------------|-----|---------------------|------------|
| EVX075SL | 3/4" FULL PORT SIDE LOAD ELECTRIC VALVE   | 300     | 3/4"      | 1"                | 1   | VP20153SH           | EVX10200   |
| EVX100SL | 1" FULL PORT SIDE LOAD ELECTRIC VALVE     | 300     | 1"        | 1"                | 1   | VP20153SH           | EVX10200   |
| EVX125SL | 1 1/4" FULL PORT SIDE LOAD ELECTRIC VALVE | 250     | 1 1/4"    | 1"                | 1   | VP20153SH           | EVX10200   |
| EVX150SL | 1 1/2" FULL PORT SIDE LOAD ELECTRIC VALVE | 250     | 1 1/2"    | 1 1/2"            | 1   | VP20153SH           | EVX20200   |
| EVX200SL | 2" STANDARD PORT SIDE LOAD ELECTRIC VALVE | 250     | 2"        | 1 1/2"            | 1   | VP20153             | EVX20200   |
| EVX220SL | 2" FULL PORT SIDE LOAD ELECTRIC VALVE     | 125     | 2"        | 2"                | 1   | VP20153             | EVX25200   |

## 3/8" - 1/2" LEV SERIES

### FEATURES

- 12 Volt DC
- Stationary current draw: less than 0.04 amps
- Rotating current draw: less than 0.40 amps
- Stall current: 0.75 amps
- Response time: 1/3 second open to close
- TFM seats
- EPDM seals
- Fiberglass reinforced polypropylene
- Integrated 1/2" mounting slot
- Standard 3 wire configuration



### 3/8"-1/2" ON/OFF ELECTRIC VALVES

| PART NO | DESCRIPTION                   | MAX PSI | PIPE SIZE | OPENING THRU BALL | QTY |
|---------|-------------------------------|---------|-----------|-------------------|-----|
| LEV038  | 3/8" FULL PORT ELECTRIC VALVE | 300     | 3/8"      | 3/8"              | 1   |
| LEV050  | 1/2" ELECTRIC VALVE           | 300     | 1/2"      | 15/32"            | 1   |



### 3/8" ELECTRIC VALVES W/ PUSH LOCK

| PART NO  | DESCRIPTION                                | MAX PSI | PIPE SIZE | OPENING THRU BALL | QTY |
|----------|--|---------|-----------|-------------------|-----|
| LEV038PL | 3/8" FULL PORT ELECTRIC VALVE W/ PUSH LOCK | 150     | 3/8"      | 3/8"              | 1   |

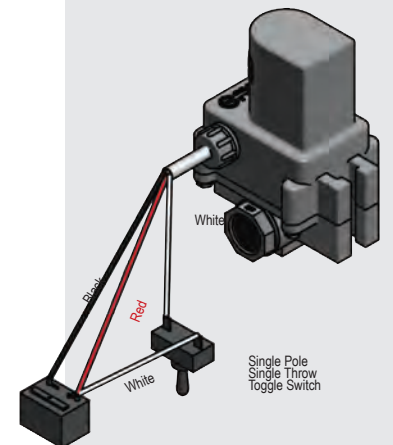

Battery  
(12 VDC)





## FEATURES

- Waterproof, rated NEMA 6P and IP68M
- LED device diagnostics on EH8 and EH9
- Durable, glass filled nylon housing
- Ignition safe, rated NEMA 7D
- 316 stainless steel stem with EPDM O-rings and PTFE packing
- Conxall, WeatherPak and Deutsch connections available
- CF8M stainless steel valve body



### KZVALVE CONXALL ELECTRICAL CONNECTION DESIGNED TO FIT RAVEN SYSTEMS

| PART NO          | DESCRIPTION                                  | SIZE   | CONTROL TYPE  | FEEDBACK   | CYCLE TIME | CV | QTY |
|------------------|--|--------|---------------|------------|------------|----|-----|
| KZ-67D331AE9SC01 | 1/2" STANDARD PORT NH3 ELECTRIC VALVE, EH9   | 1/2"   | ON/OFF        | (+) @ OPEN | 0.7 SEC    | 15 | 5   |
| KZ-S8F331AE9SC01 | 1" FULL PORT NH3 ELECTRIC VALVE, EH9         | 1"     | ON/OFF        | (+) @ OPEN | 0.7 SEC    | 68 | 5   |
| KZ-S8F3320E8SC01 | 1" FULL PORT NH3 ELECTRIC VALVE, EH9         | 1"     | FAST RATE     | N/A        | 3.0 SEC    | 68 | 5   |
| KZ-S8F22K0HU0CF1 | 1" FULL PORT NH3 ELECTRIC VALVE, EH2         | 1"     | STANDARD RATE | N/A        | 8.0 SEC    | 68 | 5   |
| KZ-67G2210DY0CF1 | 1 1/4" STANDARD PORT NH3 ELECTRIC VALVE, EH2 | 1 1/4" | ON/OFF        | N/A        | 1.5 SEC    | 48 | 5   |
| KZ-67G2220DY0CF1 | 1 1/4" STANDARD PORT NH3 ELECTRIC VALVE, EH2 | 1 1/4" | FAST RATE     | N/A        | 1.5 SEC    | 48 | 5   |
| KZ-67G22K0HU0CF1 | 1 1/4" STANDARD PORT NH3 ELECTRIC VALVE, EH2 | 1 1/4" | STANDARD RATE | N/A        | 8.0 SEC    | 48 | 5   |
| KZ-67H2210DY0CF1 | 1 1/2" STANDARD PORT NH3 ELECTRIC VALVE, EH2 | 1 1/2" | ON/OFF        | N/A        | 1.5 SEC    | 84 | 5   |
| KZ-67H2220DY0CF1 | 1 1/2" STANDARD PORT NH3 ELECTRIC VALVE, EH2 | 1 1/2" | FAST RATE     | N/A        | 1.5 SEC    | 84 | 5   |
| KZ-67H22K0HU0CF1 | 1 1/2" STANDARD PORT NH3 ELECTRIC VALVE, EH2 | 1 1/2" | STANDARD RATE | N/A        | 8.0 SEC    | 84 | 5   |

### KZVALVE INTEGRATED DEUTSCH RECEPTACLE OR ELECTRICAL CONNECTION

| PART NO          | DESCRIPTION                                | SIZE | CONTROL TYPE | FEEDBACK     | CYCLE TIME | CV  | QTY |
|------------------|--|------|--------------|--------------|------------|-----|-----|
| KZ-S8B281CEBSD01 | 1/4" STANDARD PORT NH3 ELECTRIC VALVE, EH8 | 1/4" | ON/OFF       | (+) @ CLOSED | 0.2 SEC    | 3.5 | 5   |
| KZ-S8C281CEBSD01 | 3/8" STANDARD PORT NH3 ELECTRIC VALVE, EH8 | 3/8" | ON/OFF       | (+) @ CLOSED | 0.2 SEC    | 5.2 | 5   |
| KZ-67D331CE9SD01 | 1/2" FULL PORT NH3 ELECTRIC VALVE, EH9     | 1/2" | ON/OFF       | (+) @ CLOSED | 0.7 SEC    | 15  | 5   |
| KZ-S8F331CE9SD01 | 1" FULL PORT NH3 ELECTRIC VALVE, EH9       | 1"   | ON/OFF       | (+) @ CLOSED | 0.7 SEC    | 68  | 5   |

### KZVALVE HARDWARE RETROFIT KITS

| PART NO    | DESCRIPTION                              | SIZE       | CONTROL TYPE  | QTY |
|------------|--|------------|---------------|-----|
| KZ-KRKIT   | RETROFIT KIT FOR 1 & 1 1/4" RAVEN VALVES | 1 & 1 1/4" | HARDWARE ONLY | 5   |
| KZ-KR15KIT | RETROFIT KIT FOR 1 1/2" RAVEN VALVES     | 1 1/2"     | HARDWARE ONLY | 5   |

### KZVALVE ACTUATOR OPTIONS

| PART NO     | DESCRIPTION       | CONTROL TYPE  | FEEDBACK | CYCLE TIME | QTY |
|-------------|-------------------|---------------|----------|------------|-----|
| KZ-1AE9SC01 | NH3 ACTUATOR, EH9 | ON/OFF        | N/A      | 0.7 SEC    | 5   |
| KZ-10DY0CF1 | NH3 ACTUATOR, EH9 | ON/OFF        | N/A      | 1.5 SEC    | 5   |
| KZ-K0HU0CF1 | NH3 ACTUATOR, EH2 | STANDARD RATE | N/A      | 8.0 SEC    | 5   |
| KZ-20E8SC01 | NH3 ACTUATOR, EH9 | FAST RATE     | N/A      | 1.5 SEC    | 5   |
| KZ-1CE9SD01 | NH3 ACTUATOR, EH9 | ON/OFF        | N/A      | 0.7 SEC    | 5   |
| KZ-20E7SD01 | NH3 ACTUATOR, EH9 | STANDARD RATE | N/A      | 3 SEC      | 5   |
| KZ-20E8SD01 | NH3 ACTUATOR, EH9 | FAST RATE     | N/A      | 1.7 SEC    | 5   |
| KZ-20DY0CF1 | NH3 ACTUATOR, EH2 | FAST RATE     | N/A      | 1.5 SEC    | 5   |



- Waterproof KZValve EH2 Actuator
- Conxall connector plug for Raven System
- Coupler
- Mounting bracket
- Fasteners
- Simple replacement instructions
- Note: These kits do not include valves.



## FEATURES

- Waterproof, rated NEMA 6P and IP68M
- LED device diagnostics
- Durable, glass filled nylon housing
- Ignition safe, rated NEMA 7D
- Low maintenance, reversible seat design
- Integrated Deutsch receptacle connection
- PVC ball
- PVC valve body



### KZVALVE VALVES

| PART NO  | DESCRIPTION      | SIZE   | OUTLET           | PSI @ 70 | CV    | QTY |
|----------|------------------|--------|------------------|----------|-------|-----|
| KZ-95D33 | 1/2" VALVE KIT   | 1/2"   | FNPT/SOCKET WELD | 250      | 8.0   | 5   |
| KZ-95E33 | 3/4" VALVE KIT   | 3/4"   | FNPT/SOCKET WELD | 250      | 16.0  | 5   |
| KZ-95F33 | 1" VALVE KIT     | 1"     | FNPT/SOCKET WELD | 250      | 29.0  | 5   |
| KZ-95H39 | 1 1/2" VALVE KIT | 1 1/2" | FNPT/SOCKET WELD | 125      | 90.0  | 5   |
| KZ-95I39 | 2" VALVE KIT     | 2"     | FNPT/SOCKET WELD | 125      | 150.0 | 5   |

### KZVALVE ACTUATED VALVES

| PART NO            | DESCRIPTION                             | SIZE       | CONTROL TYPE  | QTY |
|--------------------|---|------------|---------------|-----|
| KZ-95D33-1CE9S-D0P | 1 & 1 1/4" HARDWARE KIT FOR "KR" SERIES | 1 & 1 1/4" | HARDWARE ONLY | 5   |
| KZ-95F33-1CE9S-D0P | 1 1/2" HARDWARE KIT FOR "KR" SERIES     | 1 1/2"     | HARDWARE ONLY | 5   |

### KZVALVE ACTUATOR ONLY

| PART NO      | DESCRIPTION  | SIZE | CONTROL TYPE | CYCLE TYPE | QTY |
|--------------|--------------|------|--------------|------------|-----|
| KZ-20E7S-D0P | EH9 ACTUATOR | N/A  | POSITIONABLE | 3.0 SEC    | 5   |
| KZ-20E8S-D0P | EH9 ACTUATOR | N/A  | POSITIONABLE | 1.7 SEC    | 5   |
| KZ-20E9S-D0P | EH9 ACTUATOR | N/A  | POSITIONABLE | 0.7 SEC    | 5   |
| KZ-1CE7S-D0P | EH9 ACTUATOR | N/A  | ON/OFF       | 3.0 SEC    | 5   |
| KZ-1CE8S-D0P | EH9 ACTUATOR | N/A  | ON/OFF       | 1.37 SEC   | 5   |
| KZ-1CE9S-D0P | EH9 ACTUATOR | N/A  | ON/OFF       | 0.7 SEC    | 5   |
| KZ-L0E7S-D0P | EH9 ACTUATOR | N/A  | CANBUS       | 3.0 SEC    | 5   |

Any technical questions regarding KZValve products, please call (800) 288-1112 (ask for sales)



NO THREADS. NO SWEAT.

FLANGE CONNECTIONS FOR EVERY PRODUCT

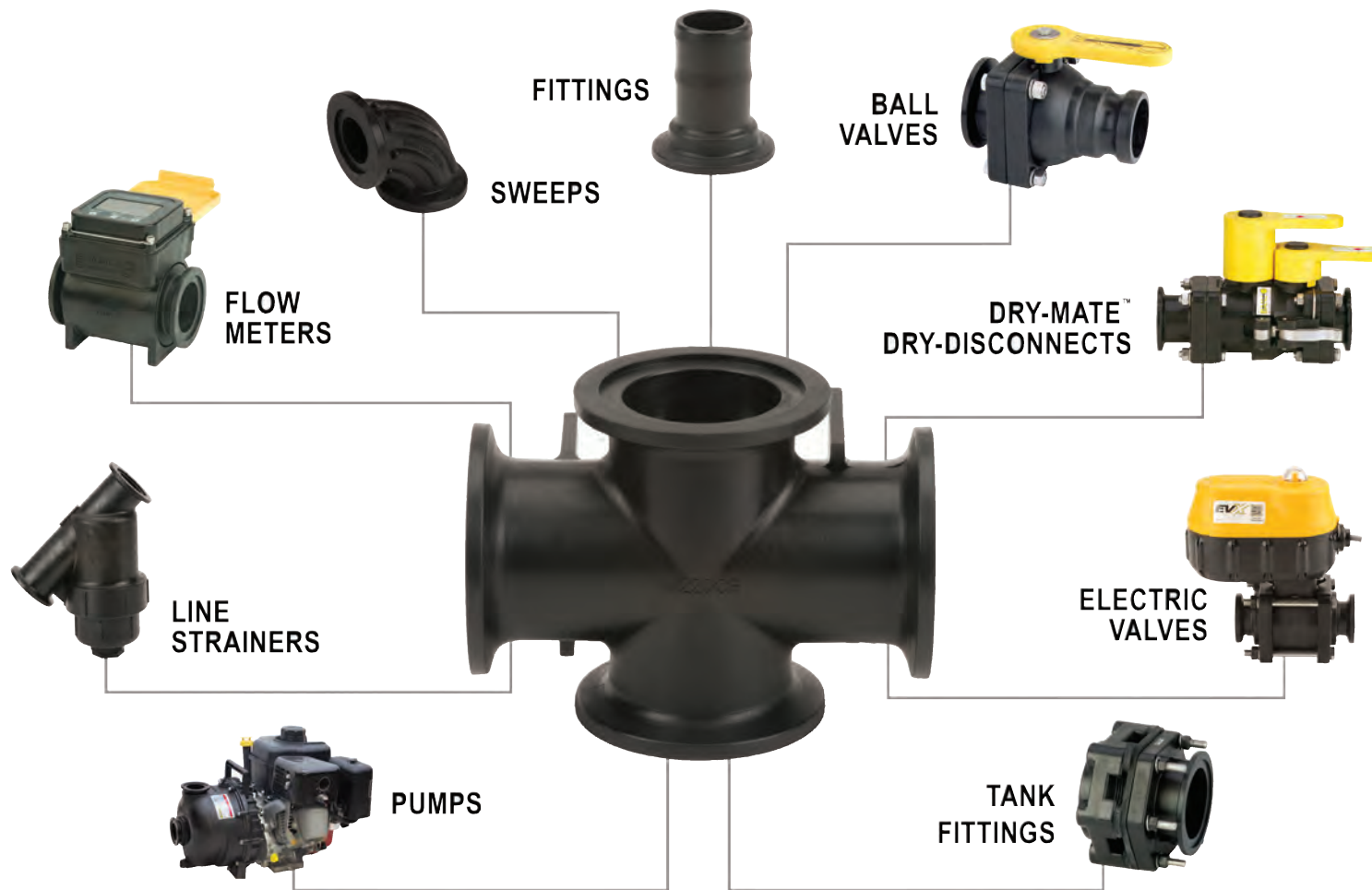

### ⚙️ SKIP THE TAPE AND SEALANT

Flange connections utilize clamps instead of threads, facilitating quick and easy assembly and disassembly while ensuring a leak-proof system. Threaded pipe needs tape or sealant, and the slightest imperfection in the pipe or seal can cause a leak. With properly installed flange connections, you won't worry about connection leaks or wait for sealant to cure.

### ⌚ SAVE TIME. SAVE MONEY.

Time spent unthreading systems and repairing leaks from faulty connections is unproductive and ultimately hits your pocketbook. Banjo's manifold flange systems get you back in the field and out of the shop in no time.

### ➡️ GET RIGHT TO THE SOURCE

With Banjo manifold flange connections, the days of spending hours unhooking entire systems of valves and fittings are over. You can directly isolate and replace the problematic part or replumb sections without disassembling the whole system.



### 1" MEVX ON/OFF WELDED ELECTRIC VALVES

| PART NO | DESCRIPTION                 | MAX PSI | PIPE SIZE | OPENING THRU BALL | QTY | OPTIONAL HANDLE KIT |
|---------|-----------------------------|---------|-----------|-------------------|-----|---------------------|
| MEVX100 | 1" FULL PORT ELECTRIC VALVE | 300     | 1"        | 1"                | 1   | VP20153SH           |

### 1" MEVX REGULATING WELDED ELECTRIC VALVES

| PART NO  | DESCRIPTION                 | MAX PSI | PIPE SIZE | OPENING THRU BALL | QTY | OPTIONAL HANDLE KIT |
|----------|-----------------------------|---------|-----------|-------------------|-----|---------------------|
| MEVXR100 | 1" FULL PORT ELECTRIC VALVE | 300     | 1"        | 1"                | 1   | VP20153SH           |

### 1" MEVX ON/OFF BOLTED ELECTRIC VALVES

| PART NO | DESCRIPTION                 | MAX PSI | PIPE SIZE | OPENING THRU BALL | QTY | OPTIONAL HANDLE KIT | REPAIR KIT |
|---------|-----------------------------|---------|-----------|-------------------|-----|---------------------|------------|
| MEVX101 | 1" FULL PORT ELECTRIC VALVE | 300     | 1"        | 1"                | 1   | VP20153SH           | EVX10200   |

### 1" MEVX REGULATING BOLTED ELECTRIC VALVES

| PART NO  | DESCRIPTION                 | MAX PSI | PIPE SIZE | OPENING THRU BALL | QTY | OPTIONAL HANDLE KIT | REPAIR KIT |
|----------|-----------------------------|---------|-----------|-------------------|-----|---------------------|------------|
| MEVXR101 | 1" FULL PORT ELECTRIC VALVE | 300     | 1"        | 1"                | 1   | VP20153SH           | EVX10200   |

## 1" MEVX SERIES

### FEATURES

- 12-volt DC operated
- 24-volt available
- Open/closed indicator
- ON/OFF has 3/4 second response
- Regulating has 4 second response
- Open / Close verification available
- IP68 waterproof
- -0 to 150F (-18 to 65C) operating
- -67 to 221F (-55 to 105C) storage
- On/Off Actuator rated to 500,000 cycles
- Regulating Actuator rated to 250,000 cycles
- Valve rated to 50,000 cycles leak-free
- Bolted valves have the same exact dimensions as our legacy EV valves.
- Additional protocols available including CAN/ISO BUS

### MATERIALS

- 316 stainless steel ball & stem
- Poly ball available on bolted valves
- Stainless steel hardware
- Fiberglass reinforced polypropylene
- PTFE seats
- FKM stem seals

### ON/OFF

- Red = +12V DC
- Black = Ground
- White = +12VDC (Open) 0VDC (Close)

### 4 WIRE REGULATING

- Red = +12V DC (Open)
- White = Ground (Open)
- Black = +12V DC (Close)
- Green = Ground (Close)



## 2" MEVX SERIES

### FEATURES

- 12-volt DC operated
- 24-volt available
- Open/closed indicator
- ON/OFF has 1½ second response
- Regulating has 4 second response
- Open / Close verification available
- IP68 waterproof
- -0 to 150F (-18 to 65C) operating
- -67 to 221F (-55 to 105C) storage
- On/Off Actuator rated to 500,000 cycles
- Regulating Actuator rated to 250,000 cycles
- Valve rated to 50,000 cycles leak-free
- Bolted valves have the same exact dimensions as our legacy EV valves.
- Additional protocols available including CAN/ISO BUS

### MATERIALS

- 316 stainless steel ball & stem
- Poly ball available on bolted standard port valves
- Stainless steel hardware
- Fiberglass reinforced polypropylene
- PTFE seats
- FKM stem seals

### ON/OFF

- Red = +12V DC
- Black = Ground
- White = +12VDC (Open)  
OVDC (Close)

### 4 WIRE REGULATING

- Red = +12V DC (Open)
- White = Ground (Open)
- Black = +12V DC (Close)
- Green = Ground (Close)



### 2" MEVX ON/OFF WELDED ELECTRIC VALVES

| PART NO | DESCRIPTION                     | MAX PSI | PIPE SIZE | OPENING THRU BALL | QTY | OPTIONAL HANDLE KIT |
|---------|---------------------------------|---------|-----------|-------------------|-----|---------------------|
| MEVX200 | 2" STANDARD PORT ELECTRIC VALVE | 300     | 2"        | 1½"               | 1   | VP20153             |
| MEVX220 | 2" FULL PORT ELECTRIC VALVE     | 250     | 2"        | 2"                | 1   | VP20153             |

### 2" MEVX REGULATING WELDED ELECTRIC VALVES

| PART NO  | DESCRIPTION                     | MAX PSI | PIPE SIZE | OPENING THRU BALL | QTY | OPTIONAL HANDLE KIT |
|----------|---------------------------------|---------|-----------|-------------------|-----|---------------------|
| MEVXR200 | 2" STANDARD PORT ELECTRIC VALVE | 250     | 2"        | 1½"               | 1   | VP20153             |
| MEVXR220 | 2" FULL PORT ELECTRIC VALVE     | 250     | 2"        | 2"                | 1   | VP20153             |

### 2" MEVX ON/OFF BOLTED ELECTRIC VALVES

| PART NO | DESCRIPTION                     | MAX PSI | PIPE SIZE | OPENING THRU BALL | QTY | OPTIONAL HANDLE KIT | REPAIR KIT |
|---------|---------------------------------|---------|-----------|-------------------|-----|---------------------|------------|
| MEVX201 | 2" STANDARD PORT ELECTRIC VALVE | 250     | 2"        | 1½"               | 1   | VP20153             | EVX20200   |
| MEVX221 | 2" FULL PORT ELECTRIC VALVE     | 125     | 2"        | 2"                | 1   | VP20153             | EVX25200   |



## 3" MEVX SERIES

### FEATURES

- 12-volt DC operated
- 24-volt available
- Open/closed indicator
- ON/OFF 3" has 4 second response
- Regulating 3" has 4 second response
- Open / Close verification available
- IP68 waterproof
- -0 to 150F (-18 to 65C) operating
- -67 to 221F (-55 to 105C) storage
- Actuator rated to 250,000 cycles
- Valve rated to 50,000 cycles leak-free
- Additional protocols available including CAN/ISO BUS

### MATERIALS

- 316 stainless steel ball & stem
- Stainless steel hardware
- Fiberglass reinforced polypropylene
- Zinc alloy lower actuator housing
- PTFE seats
- FKM stem seals

### ON/OFF

- Red = +12V DC
- Black = Ground
- White = +12VDC (Open)  
OVDC (Close)

### 4 WIRE REGULATING

- Red = +12V DC (Open)
- White = Ground (Open)
- Black = +12V DC (Close)
- Green = Ground (Close)

### 3" MEVX ON/OFF ELECTRIC VALVES

| PART NO | DESCRIPTION                 | MAX PSI | PIPE SIZE | OPENING THRU BALL | QTY |
|---------|-----------------------------|---------|-----------|-------------------|-----|
| MEVX300 | 3" FULL PORT ELECTRIC VALVE | 125     | 3"        | 3"                | 1   |

### 3" MEVX REGULATING ELECTRIC VALVES

| PART NO  | DESCRIPTION                 | MAX PSI | PIPE SIZE | OPENING THRU BALL | QTY |
|----------|-----------------------------|---------|-----------|-------------------|-----|
| MEVXR300 | 3" FULL PORT ELECTRIC VALVE | 125     | 3"        | 3"                | 1   |



# MANIFOLD FLANGE CONNECTIONS

## 1"- 3" MEVX SERIES BOTTOM & SIDE LOAD VALVES

### FEATURES

- 12-volt DC operated
- 24-volt available
- Open/closed indicator
- ON/OFF 1" has 3/4 second response
- ON/OFF 2" has 1 1/2 second response
- ON/OFF 3" has 4 second response
- Open / Close verification available
- IP68 waterproof
- -0 to 150F (-18 to 65C) operating
- -67 to 221F (-55 to 105C) storage
- 1"-2" On/Off Actuator rated to 500,000 cycles
- 3" On/Off & Regulating Actuator rated to 250,000 cycles
- Valve rated to 50,000 cycles leak-free
- Additional protocols available including CAN/ISO BUS

### MATERIALS

- 316 stainless steel ball & stem
- Stainless steel hardware
- Fiberglass reinforced polypropylene
- Zinc alloy lower actuator housing (3" only)
- PTFE seats
- FKM stem seals

### ON/OFF

- Red = +12V DC
- Black = Ground
- White = +12VDC (Open)  
0VDC (Close)

### 4 WIRE REGULATING

- Red = +12V DC (Open)
- White = Ground (Open)
- Black = +12V DC (Close)
- Green = Ground (Close)



### 1"-3" MEVX BOTTOM LOAD ELECTRIC VALVES

| PART NO   | DESCRIPTION  | MAX PSI | PIPE SIZE | OPENING THRU BALL | QTY | OPTIONAL HANDLE KIT | REPAIR KIT |
|-----------|--|---------|-----------|-------------------|-----|---------------------|------------|
| MEVX100BL | 1" FULL PORT MANIFOLD BOTTOM LOAD ELECTRIC VALVE     | 300     | 1"        | 1"                | 1   | VP20153SH           | EVX10200   |
| MEVX200BL | 2" STANDARD PORT MANIFOLD BOTTOM LOAD ELECTRIC VALVE | 250     | 2"        | 1 1/2"            | 1   | VP20153             | EVX20200   |
| MEVX220BL | 2" FULL PORT MANIFOLD BOTTOM LOAD ELECTRIC VALVE     | 125     | 2"        | 2"                | 1   | VP20153             | EVX25200   |
| MEVX300BL | 3" FULL PORT MANIFOLD BOTTOM LOAD ELECTRIC VALVE     | 125     | 3"        | 3"                | 1   | VP30153             | EVX30200   |

### 1"-2" MEVX SIDE LOAD ELECTRIC VALVES

| PART NO   | DESCRIPTION  | MAX PSI | PIPE SIZE | OPENING THRU BALL | QTY | OPTIONAL HANDLE KIT | REPAIR KIT |
|-----------|--|---------|-----------|-------------------|-----|---------------------|------------|
| MEVX100SL | 1" FULL PORT MANIFOLD SIDE LOAD ELECTRIC VALVE     | 300     | 1"        | 1"                | 1   | VP20153SH           | EVX10200   |
| MEVX200SL | 2" STANDARD PORT MANIFOLD SIDE LOAD ELECTRIC VALVE | 250     | 2"        | 1 1/2"            | 1   | VP20153             | EVX20200   |
| MEVX220SL | 2" FULL PORT MANIFOLD SIDE LOAD ELECTRIC VALVE     | 125     | 2"        | 2"                | 1   | VP20153             | EVX25200   |

### 1"-2" MEVX SIDE LOAD REGULATING ELECTRIC VALVES

| PART NO    | DESCRIPTION  | MAX PSI | PIPE SIZE | OPENING THRU BALL | QTY | OPTIONAL HANDLE KIT | REPAIR KIT |
|------------|--|---------|-----------|-------------------|-----|---------------------|------------|
| MEVXR100SL | 1" FULL PORT MANIFOLD SIDE LOAD ELECTRIC VALVE     | 300     | 1"        | 1"                | 1   | VP20153SH           | EVX10200   |
| MEVXR200SL | 2" STANDARD PORT MANIFOLD SIDE LOAD ELECTRIC VALVE | 250     | 2"        | 1 1/2"            | 1   | VP20153             | EVX20200   |
| MEVXR220SL | 2" FULL PORT MANIFOLD SIDE LOAD ELECTRIC VALVE     | 125     | 2"        | 2"                | 1   | VP20153             | EVX25200   |

# MANIFOLD FLANGE CONNECTIONS

## MEVX BANKED VALVES

### FEATURES

- Valve sizes 1"-2" SP
- Number of valves from two to five bank
- Welded or bolted valves available
- Bolted valves have the same exact dimensions as our legacy EV valves.
- Additional protocols available including CAN/ISO BUS



### MEVX ON/OFF WELDED BANKED ELECTRIC VALVES

| PART NO | DESCRIPTION                        | MAX PSI | PIPE SIZE | OPENING THRU BALL | QTY |
|---------|------------------------------------|---------|-----------|-------------------|-----|
| MEVX102 | 1" FULL PORT 2 BANK ELECTRIC VALVE | 300     | 1"        | 1"                | 1   |
| MEVX103 | 1" FULL PORT 3 BANK ELECTRIC VALVE | 300     | 1"        | 1"                | 1   |

### MEVX ON/OFF BOLTED BANKED ELECTRIC VALVES

| PART NO  | DESCRIPTION                        | MAX PSI | PIPE SIZE | OPENING THRU BALL | QTY |
|----------|------------------------------------|---------|-----------|-------------------|-----|
| MEVX1012 | 1" FULL PORT 2 BANK ELECTRIC VALVE | 300     | 1"        | 1"                | 1   |
| MEVX1013 | 1" FULL PORT 3 BANK ELECTRIC VALVE | 300     | 1"        | 1"                | 1   |
| MEVX1014 | 1" FULL PORT 4 BANK ELECTRIC VALVE | 300     | 1"        | 1"                | 1   |
| MEVX2013 | 2" STANDARD PORT ELECTRIC VALVE    | 300     | 2"        | 2"                | 1   |



### 1" ON/OFF ELECTRIC VALVES

| PART NO  | DESCRIPTION  | MAX PSI | PIPE SIZE | OPENING THRU BALL | QTY |
|----------|--|---------|-----------|-------------------|-----|
| MLEV100  | 1" MANIFOLD ELECTRIC VALVE   | 300     | 1"        | 1/2"              | 1   |
| MLEV100A | 1" MANIFOLD ELECTRIC VALVE WITH HIGHER TORQUE MOTOR, SS BALL         | 300     | 1"        | 1/2"              | 1   |
| MLEV100C | 1" MANIFOLD ELECTRIC VALVE WITH HIGHER TORQUE MOTOR, SS BALL, 3 WIRE | 300     | 1"        | 1/2"              | 1   |

## 1" LEV ELECTRIC MANIFOLD VALVE

### FEATURES

- TFM seats & EPDM seals
- 12-volt DC operated
- Internally fused/automatic reset
- Stationary current draw: less than 0.04 amps
- Rotating current draw: less than 0.40 amps
- Stall current: 0.75 amps
- 1/3 second response time
- Integrated mounting slot
- 3 wire configuration
- Higher torque motor to power through thick liquids and demanding applications. (MLEV100A)
- Reinforced nylon stem more than triples the strength of the standard 1" LEV. (MLEV100A)

### ON/OFF

- Red = +12V DC
- Black = Ground
- White = +12VDC (Open)  
0VDC (Close)



## 1" - 3" 4 & 6 BOLTED VALVES

### FEATURES

- FKM seals.
- Precision molded polypropylene is reinforced with fiberglass for additional strength
- Self-aligning ball moves freely against the PTFE seats for smooth operation. The valve opens and closes with very little pressure on the handle
- Ball is diamond turned, after molding, to make it spherically perfect, which provides precise contact between ball and seats.
- PTFE self-lubricating stem bushings and seats cannot stick or bind
- Stainless steel bolts

### REPAIR KIT INCLUDES:

- Ball
- Body gasket
- Thrust washer
- Ball seats
- Upper stem bushing
- Stem o-ring



| MANIFOLD 4 & 6 BOLTED VALVES |                                 |         |           |                   |         |                    |            |
|------------------------------|---------------------------------|---------|-----------|-------------------|---------|--------------------|------------|
| PART NO                      | DESCRIPTION                     | MAX PSI | PIPE SIZE | OPENING THRU BALL | LOT QTY | REPLACEMENT HANDLE | REPAIR KIT |
| MV100CF                      | 1" FULL PORT MANIFOLD VALVE     | 300     | 1"        | 1"                | 12      | V10153A            | V10200     |
| MV200CF                      | 2" STANDARD PORT MANIFOLD VALVE | 225     | 2"        | 1½"               | 12/BOX  | V20200             | V20200     |
| MV220CF                      | 2" FULL PORT MANIFOLD VALVE     | 300     | 2"        | 2"                | 8/BOX   | V25153             | V25200     |
| MV300                        | 3" STANDARD PORT MANIFOLD VALVE | 150     | 3"        | 2½"               | 6/BOX   | V25153             | V30200     |
| MV300CF                      | 3" FULL PORT MANIFOLD VALVE     | 200     | 3"        | 3"                | 6/BOX   | V25153             | V35200     |

## 2" BOLTED 5 WAY VALVE

### FEATURES

- FKM seals
- Precision molded polypropylene is reinforced with fiberglass for additional strength
- Self-aligning ball moves freely against the PTFE seats for smooth operation. The valve opens and closes with very little pressure on the handle
- Ball is diamond turned, after molding, to make it spherically perfect, which provides precise contact between ball and seats.
- PTFE self-lubricating stem bushings and seats cannot stick or bind
- Stainless steel bolts



| MANIFOLD BOLTED 5 WAY VALVE |                                   |         |           |                   |     |  |
|-----------------------------|-----------------------------------|---------|-----------|-------------------|-----|--|
| PART NO                     | DESCRIPTION                       | MAX PSI | PIPE SIZE | OPENING THRU BALL | QTY |  |
| MV225CF                     | 2" FULL PORT MANIFOLD 5 WAY VALVE | 100     | 2"        | 2"                | 1   |  |

## 2" STUBBY VALVES

### FEATURES

- Precision molded polypropylene is reinforced with fiberglass for additional strength.
- Self-aligning ball moves freely against the PTFE seats for smooth operation. The valve opens and closes with very little pressure on the handle.
- Ball is diamond turned, after molding, to make it spherically perfect, which provides precise contact between ball and seats.
- PTFE self-lubricating stem bushings and seats cannot stick or bind.
- Stainless steel bolts.
- Standard port size has TFE seals and Full Port size has FKM seals



| 2" MANIFOLD STUBBY VALVES |   |         |           |                   |         |                    |            |
|---------------------------|---|---------|-----------|-------------------|---------|--------------------|------------|
| PART NO                   | DESCRIPTION   | MAX PSI | PIPE SIZE | OPENING THRU BALL | LOT QTY | REPLACEMENT HANDLE | REPAIR KIT |
| VSMT200CF                 | 2" STANDARD PORT MANIFOLD VALVE FLANGE X MALE NPT W/TFE SEALS     | 150     | 2"        | 1½"               | 6       | VS20152SH          | N/A        |
| VSF200CF                  | 2" STANDARD PORT MANIFOLD VALVE FLANGE X MALE ADAPTER W/TFE SEALS | 100     | 2"        | 1½"               | 6       | VS20152SH          | N/A        |
| MVS220FP                  | 2" FULL PORT MANIFOLD VALVE FLANGE X FEMALE NPT W/FKM SEALS       | 300     | 2"        | 2"                | 6       | VS25153            | VS25200    |
| MVSF220FP                 | 2" FULL PORT MANIFOLD VALVE FLANGE X MALE ADAPTER W/FKM SEALS     | 150     | 2"        | 2"                | 9       | VS25153            | VS25200    |
| MVS220CF                  | 2" FULL PORT MANIFOLD VALVE FLANGE X FLANGE W/FKM SEALS           | 150     | 2"        | 2"                | 9       | VS25153            | VS25200    |
| MVSMT220FP                | 2" FULL PORT MANIFOLD VALVE FLANGE X MALE NPT W/FKM SEALS         | 225     | 2"        | 2"                | 9       | VS25153            | VS25200    |

Note: N/A repair kits, components available.



## 3" STUBBY VALVES

### FEATURES

- FKM seals.
- Precision molded polypropylene is reinforced with fiberglass for additional strength.
- Self-aligning ball moves freely against the PTFE seats for smooth operation. The valve opens and closes with very little pressure on the handle.
- Ball is diamond turned, after molding, to make it spherically perfect, which provides precise contact between ball and seats.
- PTFE self-lubricating stem bushings and seats cannot stick or bind.
- Stainless steel bolts.



| 3" MANIFOLD STUBBY VALVES |   |         |           |                   |         |                    |            |
|---------------------------|---|---------|-----------|-------------------|---------|--------------------|------------|
| PART NO                   | DESCRIPTION   | MAX PSI | PIPE SIZE | OPENING THRU BALL | LOT QTY | REPLACEMENT HANDLE | REPAIR KIT |
| MVSF300                   | 3" STANDARD PORT MANIFOLD VALVE FLANGE X MALE ADAPTER | 100     | 3"        | 2½"               | 6/BOX   | V25153             | VS30200    |
| MVSF300FP                 | 3" FULL PORT MANIFOLD VALVE FLANGE X MALE ADAPTER     | 100     | 3"        | 3"                | 6/BOX   | V25153             | VS35200    |
| MVSMT300                  | 3" STANDARD PORT MANIFOLD VALVE FLANGE X MALE NPT     | 225     | 3"        | 2½"               | 4       | V25153             | VS30200    |
| MVS300CF                  | 3" STANDARD PORT MANIFOLD VALVE FLANGE X FLANGE       | 200     | 3"        | 2½"               | 6/BOX   | V25153             | VS30200    |
| MVS300CFFP                | 3" FULL PORT MANIFOLD VALVE FLANGE X FLANGE           | 150     | 3"        | 3"                | 6/BOX   | V25153             | VS35200    |

## 3" FP STUBBY VALVES WITH STAINLESS STEEL

### FEATURES

- Precision molded polypropylene is reinforced with fiberglass for additional strength.
- Self-aligning ball moves freely against the PTFE seats for smooth operation. The valve opens and closes with very little pressure on the handle.
- Ball is diamond turned, after molding, to make it spherically perfect, which provides precise contact between ball and seats.
- Stainless steel bolts
- Compact design
- FKM seals



MVS300HSFP



MVSMT300HSFP

| 3" FULL PORT MANIFOLD STUBBY VALVES WITH SS |  |         |           |                   |     |                    |            |
|---|--|---------|-----------|-------------------|-----|--------------------|------------|
| PART NO                                     | DESCRIPTION  | MAX PSI | PIPE SIZE | OPENING THRU BALL | QTY | REPLACEMENT HANDLE | REPAIR KIT |
| MVS300HSFP                                  | 3" FULL PORT MANIFOLD STUBBY VALVE FLANGE X FLANGE WITH SS BALL, STEM & HANDLE   | 100     | 3"        | 3"                | 1   |                    | VS30153SS  |
| MVSMT300HSFP                                | 3" FULL PORT MANIFOLD STUBBY VALVE MALE NPT X FLANGE WITH SS BALL, STEM & HANDLE | 200     | 3"        | 3"                | 1   |                    | VS30153SS  |



## 3 WAY BOTTOM LOAD BALL VALVES

### FEATURES

- Stainless steel bolts
- Precision molded in fiberglass reinforced polypropylene for additional strength
- Self-aligning ball moves freely against the PTFE seats for smooth operation
- Ball is diamond turned after molding to make it spherically perfect, which provides precise contact between ball and seats
- PTFE self-lubricating stem bushings and seats
- FKM body seals
- Directional flow, right or left. Valve can be turned off to stop flow

### REPAIR KIT INCLUDES:

- Ball
- Body gasket
- Thrust washer
- Ball seats
- Upper stem bushing
- Stem o-ring



3 WAY BOTTOM LOAD MANIFOLD VALVES

| PART NO | DESCRIPTION                            | MAX PSI | PIPE SIZE | OPENING THRU BALL | LOT QTY | HANDLE TYPE | REPLACEMENT HANDLE | REPAIR KIT |
|---------|--|---------|-----------|-------------------|---------|-------------|--------------------|------------|
| MV100BL | 1" FP 3-WAY BOTTOM LOAD MANIFOLD VALVE | 300     | 1"        | 1"                | 6       | T           | V10353TB           | N/A        |
| MV200BL | 2" SP 3-WAY BOTTOM LOAD MANIFOLD VALVE | 225     | 2"        | 1½"               | 6       | T           | V20353TB           | V15300SL   |
| MV220BL | 2" FP 3-WAY BOTTOM LOAD MANIFOLD VALVE | 150     | 2"        | 2"                | 8/BOX   | STRAIGHT    | V25353B            | V25200BL   |
| MV300BL | 3" FP 3-WAY BOTTOM LOAD MANIFOLD VALVE | 150     | 3"        | 3"                | 4/BOX   | STRAIGHT    | V25353B            | V35200BL   |

## PRESSURE SPIKE VALVES

### FEATURES

- FKM seals.
- Precision molded polypropylene is reinforced with fiberglass for additional strength.
- 360° orientation
- Preset pressure spring



MANIFOLD PRESSURE SPIKE VALVES

| PART NO     | DESCRIPTION                           | CRACKING PRESSURE | MAX PSI | QTY |
|-------------|---------------------------------------|-------------------|---------|-----|
| MPRV100-050 | 1" X 1" MANIFOLD PRESSURE SPIKE VALVE | 50                | 300     | 1   |
| MPRV100-075 | 1" X 1" MANIFOLD PRESSURE SPIKE VALVE | 75                | 300     | 1   |
| MPRV100-100 | 1" X 1" MANIFOLD PRESSURE SPIKE VALVE | 100               | 300     | 1   |
| MPRV100-125 | 1" X 1" MANIFOLD PRESSURE SPIKE VALVE | 125               | 300     | 1   |

## 3 WAY SIDE LOAD BALL VALVES

### FEATURES

- Stainless steel bolts
- Precision molded in fiberglass reinforced polypropylene for additional strength
- Self-aligning ball moves freely against the PTFE seats for smooth operation
- Ball is diamond turned after molding to make it spherically perfect, which provides precise contact between ball and seats
- PTFE self-lubricating stem bushings and seats
- FKM body seals
- Directional flow, right or left. Valve cannot be turned off to stop flow



3 WAY SIDE LOAD MANIFOLD VALVES

| PART NO | DESCRIPTION                                    | MAX PSI | PIPE SIZE | OPENING THRU BALL | LOT QTY | HANDLE TYPE | REPLACEMENT HANDLE | REPAIR KIT |
|---------|--|---------|-----------|-------------------|---------|-------------|--------------------|------------|
| MV100SL | 1" FP 3-WAY SIDE LOAD MANIFOLD VALVE           | 300     | 1"        | 1"                | 6       | T           | V10353TB           | N/A        |
| MV200SL | 2" SP 3-WAY SIDE LOAD MANIFOLD VALVE           | 225     | 2"        | 1½"               | 5       | STRAIGHT    | V20153SH           | V15300SL   |
| MV220SL | 2" FP 3-WAY SIDE LOAD FULL PORT MANIFOLD VALVE | 100     | 2"        | 2"                | 8/BOX   | STRAIGHT    | V25153SH           | V25200BL   |

## DRY-MATE™ DRY-DISCONNECTS

### FEATURES

- Easy to use
- Minimal fluid spillage
- Reduces risk of exposure
- Wide range of chemical resistance
- When properly installed and operated, the assembly will not accidentally separate while fluid is flowing; preventing costly mishaps.
- Spillage data: 2"=4ml, 3"=15ml

### REPAIR KIT INCLUDES:

- Face seal
- Ball
- Seats
- Body gasket
- Thrust bearings
- Stem bushings



MANIFOLD DRY DISCONNECTS

| PART NO  | DESCRIPTION                                | MAX PSI | PIPE SIZE | OPENING THRU BALL | QTY | REPLACEMENT HANDLE | REPAIR KIT |
|----------|--|---------|-----------|-------------------|-----|--------------------|------------|
| DM200ACF | 2" MALE MANIFOLD DRY-MATE WITH FKM SEALS   | 100     | 2"        | 1½"               | 1   | DM20153M           | DM20200A   |
| DM200DCF | 2" FEMALE MANIFOLD DRY-MATE WITH FKM SEALS | 100     | 2"        | 1½"               | 1   | DM20153F           | DM20200D   |
| DM300ACF | 3" MALE MANIFOLD DRY-MATE WITH FKM SEALS   | 150     | 3"        | 3"                | 1   | DM35153M           | DM35200    |
| DM300DCF | 3" FEMALE MANIFOLD DRY-MATE WITH FKM SEALS | 150     | 3"        | 3"                | 1   | DM35153F           | DM35200    |

Note: Male and female sold separately



# MANIFOLD FLANGE CONNECTIONS

## BOOM NOZZLE PIPE ADAPTER

### FEATURES

- Eliminates having to thread pipe
- Quick and easy assembly
- No welding necessary
- 360° orientation



| BOOM NOZZLE PIPE ADAPTER |                             |         |         |
|--------------------------|-----------------------------|---------|---------|
| PART NO                  | DESCRIPTION                 | MAX PSI | LOT QTY |
| M100PA                   | 1" FLANGED PIPE ADAPTER     | 300     | 10      |
| M100PAC                  | 1" FLANGED PIPE ADAPTER CAP | 300     | 1       |
| M100PAT                  | 1" FLANGED PIPE ADAPTER TEE | 300     | 1       |

## INDUCTORS

### FEATURES

- Threaded or manifold ends
- Glass reinforced polypropylene
- Designed for use with a volume pump. Typical volumes (80-240 US GPM) and pressures (26-52 PSI) should be used to operate the inductor.



| MANIFOLD INDUCTORS |                                     |                  |             |              |         |
|--------------------|-------------------------------------|------------------|-------------|--------------|---------|
| PART NO            | DESCRIPTION                         | PRESSURE AT PUMP | VOLUME DRAW | OPENING SIZE | LOT QTY |
| HV200              | 2" MPT INDUCTOR                     | 225              | 49 GPM      | 7/16"        | 1       |
| MHV200             | 2" MANIFOLD INDUCTOR WITH 1/2" PORT | 300              | 37 GPM      | 5/16"        | 1       |
| MHV220A            | 2" FULL PORT MANIFOLD INDUCTOR      | 225              | 49 GPM      | 9/16"        | 5       |

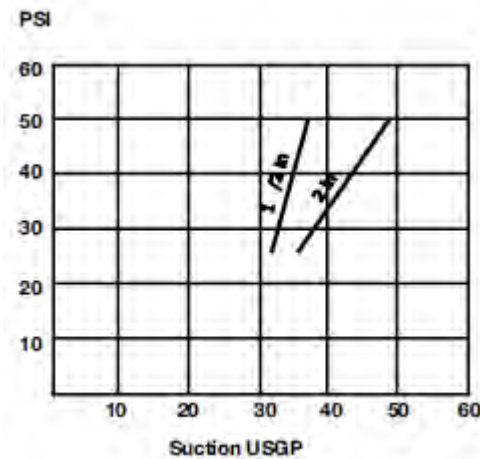

**Note:** The inductor is designed for use with a volume pump. Typical volumes and pressures used to operate the venturi would be in the 80 to 240 US GPM range at pressures from 26 to 52 PSI.

# MANIFOLD FLANGE CONNECTIONS

## INDUCTOR SYSTEMS

### FEATURES

- Installed after pump; suction completely empties inductor tank
- Keeps pump free of chemicals
- Easy assembly/installation with manifold connections found on pages 41-47.
- Choose your connections and valve
- Tank for illustration purposes only, not included

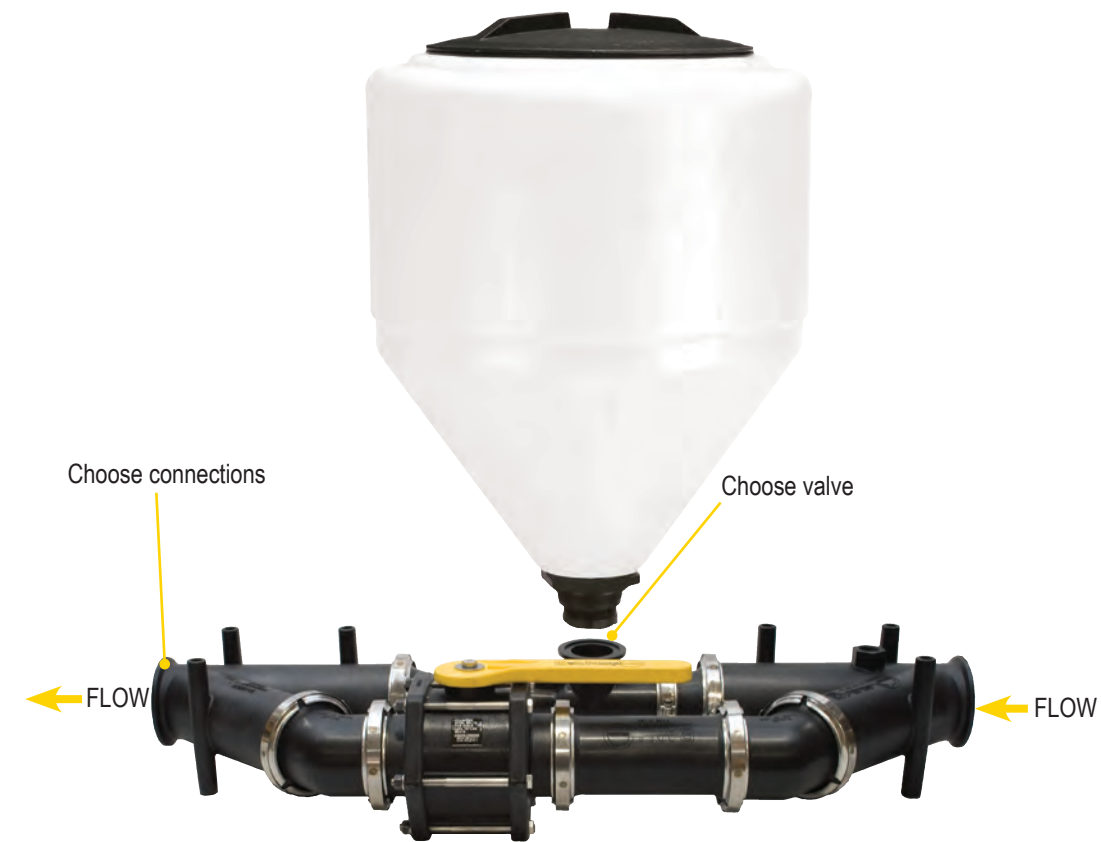

| MANIFOLD INDUCTOR SYSTEMS |   |         |     |
|---------------------------|---|---------|-----|
| PART NO                   | DESCRIPTION   | MAX PSI | QTY |
| MIS220                    | 2" FULL PORT MANIFOLD INDUCTOR SYSTEM FLANGE X FLANGE ASSEMBLED | 225     | 1   |
| MIS300                    | 3" FULL PORT MANIFOLD INDUCTOR SYSTEM FLANGE X FLANGE ASSEMBLED | 150     | 1   |

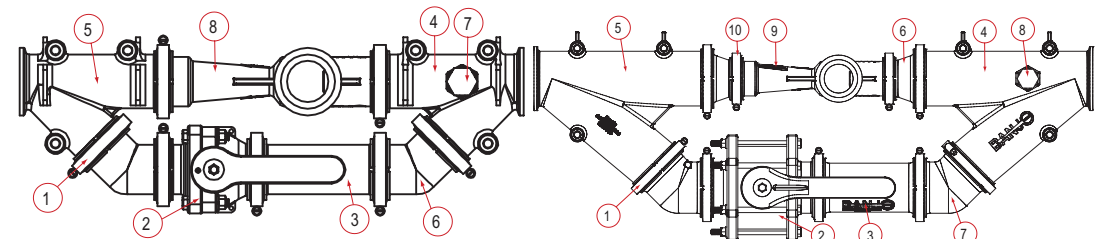

| MANIFOLD INDUCTORS |           |   |         | MANIFOLD INDUCTORS |            |   |         |
|--------------------|-----------|---|---------|--------------------|------------|---|---------|
| ITEM               | PART NO   | DESCRIPTION                                   | LOT QTY | ITEM               | PART NO    | DESCRIPTION                                   | LOT QTY |
| 1                  | FC220     | 220 SERIES WORM SCREW CLAMP                   | 10/BAG  | 1                  | FC300      | 300 SERIES WORM SCREW CLAMP                   | 10/BAG  |
| 2                  | MVS220CF  | 2" FP FLANGE X 2" FP FLANGE                   | 9       | 2                  | MV301CF    | 3" FP FLANGE X 3" FP FLANGE                   | 1       |
| 3                  | M220CPG6  | 2" X 2" FULL PORT FLANGE X 6"                 | 5       | 3                  | M300CPG7   | 3" X 3" FULL PORT FLANGE X 7"                 | 1       |
| 4                  | M220YG45  | 2" FULL PORT 45° Y FLANGE W/ 3/4" GAUGE PORT* | 1       | 4                  | M300YG45   | 3" FULL PORT 45° Y FLANGE W/ 3/4" GAUGE PORT* | 1       |
| 5                  | M220Y45   | 2" FULL PORT 45° Y FLANGE                     | 5       | 5                  | M300Y45    | 3" FULL PORT 45° Y FLANGE                     | 1       |
| 6                  | M220CPG45 | 2" FULL PORT 45° COUPLING                     | 10/BAG  | 6                  | M300220CPG | 3" X 2" FULL PORT REDUCER FLANGE              | 1       |
| 7                  | PLUG075   | 3/4" PIPE PLUG                                | 10/BAG  | 7                  | M300CPG45  | 3" FULL PORT 45° COUPLING                     | 1       |
| 8                  | MHV220A   | 2" FULL PORT POLY VENTURI                     | 5       | 8                  | PLUG075    | 3/4" PIPE PLUG                                | 10/BAG  |
| 9                  | MHV220A   | 2" FULL PORT POLY VENTURI                     | 5       | 9                  | MHV220A    | 2" FULL PORT POLY VENTURI                     | 5       |
| 10                 | FC220     | 220 SERIES WORM SCREW CLAMP                   | 10/BAG  | 10                 | FC220      | 220 SERIES WORM SCREW CLAMP                   | 10/BAG  |
| N/S                | M221G     | 2" FULL PORT EPDM MANIFOLD GASKET WITH RIB    | 30      | N/S                | M221G      | 2" FULL PORT EPDM MANIFOLD GASKET WITH RIB    | 30      |
| N/S                | M301G     | 3" EPDM MANIFOLD GASKET WITH RIB              | 50      | N/S                | M301G      | 3" EPDM MANIFOLD GASKET WITH RIB              | 50      |



## FLOW METERS

### FEATURES

- Displays overall total volume and batch total volume
- Flow rate allows for Gallons or Liters per minute
- The display reads 6 digits for rate, 8 digits for total and 1 decimal place reading in tenths
- Magnetic style meter with stainless steel electrodes
- Self calibrating meter
- Measures water and most conductive liquids
- Flow meters will not read petroleum based liquids
- Easy to change six (6) AA batteries
- No moving parts to fail during use
- Glass-reinforced polypropylene
- Temperature range from 0°F to 150°F
- ±1% of reading (between 10% and 100% of maximum flow)
- ±3% of reading (between cutoff and 10% of maximum flow)
- There are 3 photoeyes located on the face of the flow meter. These are not push buttons; to activate you must hold your finger over the photoeye for 2-4 seconds
- It is recommended to have at least 10X the diameter of straight pipe before and after the flow meter



MFM100



MFM220



MFM300

### FLOW METERS

| PART NO | DESCRIPTION                      | MAX PSI | GPM     | QTY |
|---------|----------------------------------|---------|---------|-----|
| MFM100  | 1" FULL PORT MANIFOLD FLOW METER | 200     | 110 GPM | 1   |
| MFM220  | 2" FULL PORT MANIFOLD FLOW METER | 200     | 300 GPM | 1   |
| MFM300  | 3" FULL PORT FLOW METER          | 200     | 670 GPM | 1   |

## SWEEPS

### FEATURES

- Direct replacement for standard 90° flanged couplings
- Positive seals
- Quick and easy assembly
- Easy on/off hose connections
- 360° orientation
- Improved flow for max GPM



M100125BRBSWP90



M100BRBSWP90



M100BRBSWPG90



M100SWP90



M100SWPG90



M200SWP90



M220200SWP90



M220ASWP90



M220BRBSWP90



M220MPTSWP90



M220SWP90



M220SWPG90



M300ASWP90



M300BRBSWP90



M300MPTSWP90



M300SWP90



M300SWPG90

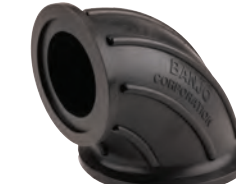

M300220SWP90

### SWEEPS

| PART NO         | DESCRIPTION   | MAX PSI | LOT QTY |
|-----------------|---|---------|---------|
| M100125BRBSWP90 | 1" FLANGE X 1 1/4" HOSE BARB SWEEP                          | 300     | 10/BAG  |
| M100BRBSWP90    | 1" FLANGE X HOSE BARB SWEEP                                 | 300     | 10/BAG  |
| M100BRBSWPG90   | 1" FULL PORT FLANGE X 1" HOSE BARB SWEEP W/ 1/4" GAUGE PORT | 300     | 10/BAG  |
| M100SWP90       | 1" FLANGE X FLANGE SWEEP                                    | 300     | 10/BAG  |
| M100SWPG90      | 1" FLANGE X FLANGE SWEEP W/ 1/4" GAUGE PORT                 | 300     | 10/BAG  |
| M200SWP90       | 2" FLANGE X FLANGE SWEEP                                    | 300     | 10/BAG  |
| M200150BRBSWP90 | 2" FLANGE X 1 1/2" HOSE BARB SWEEP                          | 300     | 10/BAG  |
| M220200SWP90    | 2" FULL PORT FLANGE X 2" FLANGE SWEEP                       | 225     | 10/BAG  |
| M220ASWP90      | 2" FULL PORT FLANGE X MALE ADAPTER SWEEP                    | 200     | 10/BAG  |
| M220BRBSWP90    | 2" FULL PORT FLANGE X HOSE BARB SWEEP                       | 225     | 10      |
| M220MPTSWP90    | 2" FULL PORT FLANGE X MALE NPT THREAD SWEEP                 | 300     | 1       |
| M220SWP90       | 2" FULL PORT FLANGE X FLANGE SWEEP                          | 225     | 10/BAG  |
| M220SWPG90      | 2" FULL PORT FLANGE X FLANGE SWEEP W/ 1/4" GAUGE PORT       | 225     | 1       |
| M221SWP90       | 2" FULL PORT MANIFOLD 90° SWEEP                             | 225     | 1       |
| M300ASWP90      | 3" FLANGE X MALE ADAPTER SWEEP                              | 100     | 1       |
| M300BRBSWP90    | 3" FLANGE X HOSE BARB SWEEP                                 | 225     | 1       |
| M300BRBSWPG90   | 3" FLANGE X HOSE BARB SWEEP W/ 1/4" GAUGE PORT              | 225     | 1       |
| M300MPTSWP90    | 3" FLANGE X MALE NPT THREAD SWEEP                           | 200     | 1       |
| M300SWP90       | 3" FLANGE X FLANGE SWEEP                                    | 200     | 1       |
| M300SWPG90      | 3" FLANGE X FLANGE SWEEP W/ 1/4" GAUGE PORT                 | 200     | 1       |
| M300220SWP90    | 3" FULL PORT FLANGE X 2" FULL PORT FLANGE SWEEP             | 300     | 1       |



## FITTINGS

### FEATURES

- Quick and easy assembly
- Positive seals
- Easy on/off hose connections
- 360° orientation
- Parts must be ordered in lot quantities.



| SWIVEL  |                                     |         |     |
|---------|-------------------------------------|---------|-----|
| PART NO | DESCRIPTION                         | MAX PSI | QTY |
| MSW220  | 2" FULL PORT MANIFOLD FLANGE SWIVEL | 200     | 1   |

| CHECK VALVES |  |                       |         |         |
|--------------|--|-----------------------|---------|---------|
| PART NO      | DESCRIPTION                            | CRACKING PRESSURE PSI | MAX PSI | LOT QTY |
| MCV100       | 1" FLANGED CHECK VALVE                 | 1                     | 300     | 10      |
| MCV200       | 2" FLANGED CHECK VALVE                 | 0.5                   | 300     | 10      |
| MCV100V      | 1" MANIFOLD CHECK VALVE                | 1                     | 300     | 1       |
| MCV221       | 2" FULL PORT FLANGED CHECK VALVE       | >0.5                  | 200     | 10      |
| MCV300       | 3" FLANGED CHECK VALVE W/5 LB SPRING   | 1.5                   | 200     | 1       |
| MCV301       | 3" FLANGED CHECK VALVE W/1/2 LB SPRING | >0.5                  | N/A     | 1       |

| PVC GLUE SOCKET |  |         |         |
|-----------------|--|---------|---------|
| PART NO         | DESCRIPTION                                      | MAX PSI | LOT QTY |
| M101GSA         | 1" FULL PORT FLANGE X 1" PVC GLUE SOCKET FITTING | 300     | 10      |
| M221GSA         | 2" FULL PORT FLANGE X 2" PVC GLUE SOCKET FITTING | 300     | 10      |
| M301GSA         | 3" FULL PORT FLANGE X 3" PVC GLUE SOCKET FITTING | 300     | 1       |

| 316 SS SOCKET WELD |   |         |         |
|--------------------|---|---------|---------|
| PART NO            | DESCRIPTION   | MAX PSI | LOT QTY |
| M100SWFSS          | 1" FLANGE X 1" SOCKET WELD FITTING                  | 300     | 10      |
| M200SWFSS          | 2" FLANGE X 2" SOCKET WELD FITTING                  | 300     | 1       |
| M220SWFSS          | 2" FULL PORT FLANGE X 2" SOCKET WELD FITTING        | 300     | 10      |
| M220375SWFSS       | 2" FULL PORT FLANGE X 2" SOCKET WELD FITTING X 3/4" | 300     | 1       |
| M300SWFSS          | 3" FLANGE X 3" SOCKET WELD FITTING                  | 300     | 1       |
| M300375SWFSS       | 3" FLANGE X 3" SOCKET WELD FITTING X 3/4"           | 300     | 1       |

| COUPLINGS    |  |         |         |
|--------------|--|---------|---------|
| PART NO      | DESCRIPTION  | MAX PSI | LOT QTY |
| M100CPG      | 1" MANIFOLD COUPLING 2 1/4" LONG                         | 300     | 10/BAG  |
| M100CPG025G  | 1" MANIFOLD COUPLING 2 1/4" PORT                         | 300     | 10/BAG  |
| M101CPG      | 1" MANIFOLD COUPLING 2 1/4" LONG W/ BLIND GAUGE PORT     | 300     | 10/BAG  |
| M200CPG      | 2" MANIFOLD COUPLING 4 1/2" LONG                         | 300     | 10/BAG  |
| M200CPG025G  | 2" MANIFOLD COUPLING 4 1/2" LONG W/ 1/4" PORT            | 300     | 10/BAG  |
| M200CPG038G  | 2" MANIFOLD COUPLING 4 1/2" LONG W/ 3/8" PORT            | 300     | 10/BAG  |
| M201CPG      | 2" MANIFOLD COUPLING 4 1/2" LONG W/ BLIND GAUGE PORT     | 300     | 10/BAG  |
| M220CPG      | 2" FULL PORT MANIFOLD COUPLING 2 31/32" LONG             | 300     | 10/BAG  |
| M220CPG2GISO | 2" FULL PORT MANIFOLD COUPLING 2" LONG W/ G 1/4" PORT    | 300     | 10/BAG  |
| M220CPG3G    | 2" FULL PORT MANIFOLD COUPLING 3" LONG W/ 1/2" PORTS (3) | 225     | 10/BAG  |
| M220CPG6     | 2" FULL PORT MANIFOLD COUPLING 6" LONG                   | 300     | 5       |
| M220CPG6025G | 2" FULL PORT MANIFOLD COUPLING 6" LONG W/ 1/4" PORTS     | 300     | 10/BAG  |
| M221CPG      | 2" FP MANIFOLD COUPLING 3" LONG W/ 3 BLIND GAUGE PORTS   | 300     | 1       |
| M221CPG6     | 2" FP MANIFOLD COUPLING 6" LONG W/ BLIND GAUGE PORT      | 300     | 10/BAG  |
| M300CPG      | 3" FULL PORT MANIFOLD COUPLING 4" LONG                   | 200     | 1       |
| M300CPG2     | 3" FP MANIFOLD COUPLING 4" LONG W/ BLIND GAUGE PORT      | 200     | 1       |
| M300CPG7     | 3" FULL PORT MANIFOLD COUPLING 7" LONG                   | 225     | 1       |
| M300CPG12G   | 3" FP MANIFOLD COUPLING 12" LONG W/ 1/2" GAUGE PORT      | 150     | 1       |
| M300CPG55    | 3" MANIFOLD COUPLING 5.5" LONG                           | 150     | 1       |
| M300CPG55G   | 3" FULL PORT MANIFOLD COUPLING 5.5" LONG W/ 1/4" PORT    | 150     | 1       |
| M300CPG7025G | 3" MANIFOLD COUPLING 7" LONG W/ 1/4" PORT                | 300     | 1       |
| M300CPG2GISO | 3" MANIFOLD COUPLING 2" LONG W/ G 1/4" GAUGE PORT        | 300     | 1       |
| M301CPG7     | 3" MANIFOLD COUPLING 7" LONG                             | 225     | 1       |



## FITTINGS

### FEATURES

- Quick and easy assembly
- Positive seals
- Easy on/off hose connections
- 360° orientation
- Parts must be ordered in lot quantities.

| 45° COUPLINGS |                              |         |         |
|---------------|------------------------------|---------|---------|
| PART NO       | DESCRIPTION                  | MAX PSI | LOT QTY |
| M100CPG45     | 1" X 1" 45° FLANGE           | 300     | 10/BAG  |
| M200CPG45     | 2" X 2" 45° FLANGE           | 300     | 10/BAG  |
| M220CPG45     | 2" X 2" FULL PORT 45° FLANGE | 225     | 10/BAG  |
| M300CPG45     | 3" X 3" FULL PORT 45° FLANGE | 225     | 1       |

| 90° COUPLINGS |                              |         |         |
|---------------|------------------------------|---------|---------|
| PART NO       | DESCRIPTION                  | MAX PSI | LOT QTY |
| M100CPG90     | 1" X 1" 90° FLANGE           | 300     | 10/BAG  |
| M200CPG90     | 2" X 2" 90° FLANGE           | 300     | 10/BAG  |
| M200CPG90SH   | 2" X 2" 90° SHORT FLANGE     | 300     | 10/BAG  |
| M220CPG90     | 2" X 2" 90° FULL PORT FLANGE | 200     | 10/BAG  |
| M300CPG90     | 3" X 3" 90° FULL PORT FLANGE | 200     | 1       |

| 45° Y FLANGED COUPLINGS |  |         |         |
|-------------------------|--|---------|---------|
| PART NO                 | DESCRIPTION                                  | MAX PSI | LOT QTY |
| M200YG45                | 2" 45° Y FLANGE W/ 3/4" GAUGE PORT           | 225     | 1       |
| M220Y45                 | 2" FULL PORT 45° Y FLANGE                    | 300     | 5       |
| M220YG45                | 2" FULL PORT 45° Y FLANGE W/ 3/4" GAUGE PORT | 225     | 1       |
| M300Y45                 | 3" FULL PORT 45° Y FLANGE                    | 200     | 1       |
| M300YG45                | 3" FULL PORT 45° Y FLANGE W/ 3/4" GAUGE PORT | 200     | 1       |

| 3" MANIFOLD WYE |   |         |     |
|-----------------|---|---------|-----|
| PART NO         | DESCRIPTION   | MAX PSI | QTY |
| M300220WYCG     | M300 X M220 X M220 X M220 FULL PORT FLANGE WYE W/ 1/4" GAUGE PORT | 300     | 1   |

| REDUCER COUPLINGS |                                  |         |         |
|-------------------|----------------------------------|---------|---------|
| PART NO           | DESCRIPTION                      | MAX PSI | LOT QTY |
| M200100CPG        | 2" X 1" REDUCER FLANGE           | 300     | 10/BAG  |
| M220100CPG        | 2" FULL PORT X 1" REDUCER FLANGE | 225     | 10/BAG  |
| M220200CPG        | 2" FULL PORT X 2" REDUCER FLANGE | 225     | 10/BAG  |
| M300200CPG        | 3" X 2" REDUCER FLANGE           | 225     | 1       |
| M300220CPG        | 3" X 2" FULL PORT REDUCER FLANGE | 225     | 1       |

| TEES       |   |         |         |
|------------|---|---------|---------|
| PART NO    | DESCRIPTION                               | MAX PSI | LOT QTY |
| M100TEE    | 1" FLANGED TEE                            | 300     | 10/BAG  |
| M101TEE    | 1" FLANGED TEE LONG                       | 300     | 10      |
| M200100TEE | 2" X 1" FLANGED TEE                       | 300     | 10      |
| M200TEE    | 2" FLANGED TEE                            | 200     | 10/BAG  |
| M220100TEE | 2" FULL PORT FLANGED TEE X 1" FLANGED TEE | 225     | 10      |
| M220200TEE | 2" FULL PORT FLANGED TEE X 2" FLANGED TEE | 300     | 10      |
| M220TEE    | 2" FULL PORT FLANGED TEE                  | 225     | 10      |
| M300TEE    | 3" FLANGED TEE                            | 225     | 1       |

| U BOLTS |                            |         |         |
|---------|----------------------------|---------|---------|
| PART NO | DESCRIPTION                | MAX PSI | LOT QTY |
| UB100   | 100 SERIES MOUNTING U BOLT | N/A     | 1       |
| UB202   | 2 SERIES MOUNTING U BOLT   | N/A     | 10      |
| UB220   | 220 SERIES MOUNTING U BOLT | N/A     | 10      |



## FITTINGS

### FEATURES

- Quick and easy assembly
- Positive seals
- Easy on/off hose connections
- 360° orientation
- Parts must be ordered in lot quantities.



| SS BUTT WELD ADAPTER |  |         |     |
|----------------------|--|---------|-----|
| PART NO              | DESCRIPTION                                    | MAX PSI | QTY |
| M220BWASS            | 2" FULL PORT STAINLESS STEEL BUTT WELD ADAPTER | 300     | 1   |



| FEMALE NPT THREAD |  |         |         |
|-------------------|--|---------|---------|
| PART NO           | DESCRIPTION                            | MAX PSI | LOT QTY |
| M100050FPT        | 1" FLANGE X 1/2" FEMALE THREAD         | 300     | 10/BAG  |
| M100075FPT        | 1" FLANGE X 3/4" FEMALE THREAD         | 300     | 10/BAG  |
| M100FPT           | 1" FLANGE X 1" FEMALE THREAD           | 300     | 10/BAG  |
| M200FPT           | 2" FLANGE X 2" FEMALE THREAD           | 300     | 10/BAG  |
| M200150FPT        | 2" FLANGE X 1 1/2" FEMALE THREAD       | 300     | 10/BAG  |
| M220FPT           | 2" FULL PORT FLANGE X 2" FEMALE THREAD | 300     | 10/BAG  |
| M300FPT           | 3" FLANGE X 3" FEMALE THREAD           | 200     | 10/BAG  |



| MALE THREAD |                                      |         |         |
|-------------|--------------------------------------|---------|---------|
| PART NO     | DESCRIPTION                          | MAX PSI | LOT QTY |
| M100075MPT  | 1" FLANGE X 3/4" MALE THREAD         | 300     | 10/BAG  |
| M100MPT     | 1" FLANGE X 1" MALE THREAD           | 300     | 10/BAG  |
| M100125MPT  | 1" FLANGE X 1 1/4" MALE THREAD       | 300     | 10/BAG  |
| M200125MPT  | 2" FLANGE X 1 1/4" MALE THREAD       | 300     | 10/BAG  |
| M200150MPT  | 2" FLANGE X 1 1/2" MALE THREAD       | 300     | 10/BAG  |
| M200MPT     | 2" FLANGE X 2" MALE THREAD           | 300     | 10/BAG  |
| M220MPT     | 2" FULL PORT FLANGE X 2" MALE THREAD | 300     | 10/BAG  |
| M300MPT     | 3" FLANGE X 3" MALE THREAD           | 300     | 1       |



| 316 SS MALE THREAD |  |         |     |
|--------------------|--|---------|-----|
| PART NO            | DESCRIPTION                              | MAX PSI | QTY |
| M100MPTSS          | 1" FLANGE X 1" MALE THREAD               | 300     | 1   |
| M200125MPTSS       | 2" FLANGE X 1 1/4" MALE THREAD           | 300     | 1   |
| M200150MPTSS       | 2" FLANGE X 1 1/2" MALE THREAD           | 300     | 1   |
| M200MPTSS          | 2" FLANGE X 2" MALE THREAD               | 300     | 1   |
| M220150MPTSS       | 2" FULL PORT FLANGE X 1 1/2" MALE THREAD | 300     | 1   |
| M220MPTSS          | 2" FULL PORT FLANGE X 2" MALE THREAD     | 300     | 1   |
| M300220MPTSS       | 3" FLANGE X 2" FULL PORT MALE THREAD     | 300     | 1   |
| M300MPTSS          | 3" FLANGE X 3" MALE THREAD               | 300     | 1   |

## FITTINGS

### FEATURES

- Quick and easy assembly
- Positive seals
- Easy on/off hose connections
- 360° orientation
- Parts must be ordered in lot quantities.



| PLUGS      |  |         |         |
|------------|--|---------|---------|
| PART NO    | DESCRIPTION                            | MAX PSI | LOT QTY |
| M100PLG    | 1" FLANGE PLUG                         | 300     | 10/BAG  |
| M200PLG    | 2" FLANGE PLUG                         | 300     | 10/BAG  |
| M220PLG    | 2" FULL PORT FLANGE PLUG               | 300     | 10/BAG  |
| M300PLG    | 3" FULL PORT FLANGE PLUG               | 225     | 10/BAG  |
| M100PLG025 | 1" FLANGE PLUG WITH 1/4" FPT           | 300     | 10/BAG  |
| M100PLG050 | 1" FLANGE PLUG WITH 1/2" FPT           | 300     | 10/BAG  |
| M200PLG025 | 2" FLANGE PLUG WITH 1/4" FPT           | 225     | 10/BAG  |
| M200PLG038 | 2" FLANGE PLUG WITH 3/8" FPT           | 300     | 10/BAG  |
| M200PLG050 | 2" FLANGE PLUG WITH 1/2" FPT           | 225     | 10/BAG  |
| M200PLG075 | 2" FLANGE PLUG WITH 3/4" FPT           | 225     | 10/BAG  |
| M200PLG100 | 2" FLANGE PLUG WITH 1" FPT             | 225     | 10/BAG  |
| M220PLG038 | 2" FULL PORT FLANGE PLUG WITH 3/8" FPT | 150     | 10/BAG  |
| M220PLG075 | 2" FULL PORT FLANGE PLUG WITH 3/4" FPT | 225     | 10/BAG  |
| M300PLG075 | 3" FLANGE PLUG WITH 3/4" FPT           | 200     | 1       |
| M300PLG100 | 3" FLANGE PLUG WITH 1" FPT             | 200     | 1       |



| FEMALE COUPLER |   |         |         |
|----------------|---|---------|---------|
| PART NO        | DESCRIPTION   | MAX PSI | LOT QTY |
| M220D          | 2" FULL PORT FLANGE X 2" FEMALE COUPLER             | 225     | 20      |
| M303D          | 3" FULL PORT FLANGE X 3" FEMALE COUPLER WITH 3 ARMS | 225     | 10      |



| MALE ADAPTER |                                       |         |         |
|--------------|---------------------------------------|---------|---------|
| PART NO      | DESCRIPTION                           | MAX PSI | LOT QTY |
| M100A        | 1" FLANGE X 1" MALE ADAPTER           | 300     | 10/BAG  |
| M200A        | 2" FLANGE X 2" MALE ADAPTER           | 300     | 10/BAG  |
| M220A        | 2" FULL PORT FLANGE X 2" MALE ADAPTER | 225     | 10/BAG  |
| M300A        | 3" FULL PORT FLANGE X 3" MALE ADAPTER | 100     | 1       |
| M300400A     | 3" MANIFOLD FLANGE X 4" MALE COUPLER  | 75      | 1       |



| CROSS   |                            |         |         |
|---------|----------------------------|---------|---------|
| PART NO | DESCRIPTION                | MAX PSI | LOT QTY |
| M100CR  | 1" FLANGED CROSS           | 300     | 10/BAG  |
| M200CR  | 2" FLANGED CROSS           | 300     | 10      |
| M220CR  | 2" FULL PORT FLANGED CROSS | 200     | 10      |
| M300CR  | 3" FLANGED CROSS           | 125     | 1       |



# MANIFOLD FLANGE CONNECTIONS

## FITTINGS

### FEATURES

- Quick and easy assembly
- Positive seals
- Easy on/off hose connections
- 360° orientation
- Parts must be ordered in lot quantities.



| HOSE BARB  |  |         |         |
|------------|--|---------|---------|
| PART NO    | DESCRIPTION                            | MAX PSI | LOT QTY |
| M100075BRB | 1" FLANGE X 3/4" HOSE BARB             | 300     | 10/BAG  |
| M100BRB    | 1" FLANGE X 1" HOSE BARB               | 300     | 10/BAG  |
| M100125BRB | 1" FLANGE X 1 1/4" HOSE BARB           | 300     | 10/BAG  |
| M200100BRB | 2" FLANGE X 1" HOSE BARB               | 300     | 10/BAG  |
| M200125BRB | 2" FLANGE X 1 1/4" HOSE BARB           | 300     | 10/BAG  |
| M200150BRB | 2" FLANGE X 1 1/2" HOSE BARB           | 300     | 10/BAG  |
| M200BRB    | 2" FLANGE X 2" HOSE BARB               | 300     | 10/BAG  |
| M220100BRB | 2" FULL PORT FLANGE X 1" HOSE BARB     | 300     | 10/BAG  |
| M220125BRB | 2" FULL PORT FLANGE X 1 1/4" HOSE BARB | 300     | 10/BAG  |
| M220150BRB | 2" FULL PORT FLANGE X 1 1/2" HOSE BARB | 300     | 10/BAG  |
| M220BRB    | 2" FULL PORT FLANGE X 2" HOSE BARB     | 300     | 10/BAG  |
| M300220BRB | 3" FLANGE X 2" FULL PORT HOSE BARB     | 125     | 1       |
| M300400BRB | 3" FLANGE X 4" HOSE BARB               | 150     | 1       |
| M300BRB    | 3" FLANGE X 3" HOSE BARB               | 200     | 1       |

| 90° HOSE BARB ELBOW |  |         |         |
|---------------------|--|---------|---------|
| PART NO             | DESCRIPTION                                | MAX PSI | LOT QTY |
| M100075BRB90        | 1" FLANGE X 3/4" 90° HOSE BARB             | 300     | 10/BAG  |
| M100BRB90           | 1" FLANGE X 1" 90° HOSE BARB               | 300     | 10/BAG  |
| M100125BRB90        | 1" FLANGE X 1 1/4" 90° HOSE BARB           | 300     | 10/BAG  |
| M100150BRB90        | 1" FLANGE X 1 1/2" 90° HOSE BARB           | 300     | 10/BAG  |
| M200100BRB90        | 2" FLANGE X 1" 90° HOSE BARB               | 300     | 10/BAG  |
| M200125BRB90        | 2" FLANGE X 1 1/4" 90° HOSE BARB           | 300     | 10/BAG  |
| M200150BRB90        | 2" FLANGE X 1 1/2" 90° HOSE BARB           | 300     | 10/BAG  |
| M200BRB90           | 2" FLANGE X 2" 90° HOSE BARB               | 300     | 10/BAG  |
| M220150BRB90        | 2" FULL PORT FLANGE X 1 1/2" 90° HOSE BARB | 300     | 10/BAG  |
| M220BRB90           | 2" FULL PORT FLANGE X 2" 90° HOSE BARB     | 300     | 10/BAG  |
| M300220BRB90        | 3" FLANGE X 2" 90° FULL PORT HOSE BARB     | 300     | 1       |
| M300BRB90           | 3" FLANGE X 3" 90° HOSE BARB               | 150     | 1       |

| 45° HOSE BARB ELBOW |  |         |         |
|---------------------|--|---------|---------|
| PART NO             | DESCRIPTION                                  | MAX PSI | LOT QTY |
| M100BRB45           | 1" FLANGE X 1" 45° HOSE BARB ELBOW           | 300     | 10/BAG  |
| M200BRB45           | 2" FLANGE X 2" 45° HOSE BARB ELBOW           | 300     | 10/BAG  |
| M200125BRB45        | 2" FLANGE X 1 1/4" 45° HOSE BARB ELBOW       | 300     | 10/BAG  |
| M200150BRB45        | 2" FLANGE X 1 1/2" 45° HOSE BARB ELBOW       | 300     | 10/BAG  |
| M220BRB45           | 2" FULL PORT FLANGE X 2" 45° HOSE BARB ELBOW | 300     | 10/BAG  |
| M300BRB45           | 3" FLANGE X 3" 45° HOSE BARB ELBOW           | 150     | 1       |

| HOSE BARB TEE |  |         |         |
|---------------|--|---------|---------|
| PART NO       | DESCRIPTION                            | MAX PSI | LOT QTY |
| M100050HBT    | 1" FLANGE X 1/2" HOSE BARB TEE         | N/A     | 10/BAG  |
| M100075HBT    | 1" FLANGE X 3/4" HOSE BARB TEE         | N/A     | 10/BAG  |
| M100100HBT    | 1" FLANGE X 1" HOSE BARB TEE           | 300     | 10/BAG  |
| M100125HBT    | 1" FLANGE X 1 1/4" HOSE BARB TEE       | 300     | 10/BAG  |
| M220150HBT    | 1 1/2" FLANGE X 1 1/2" HOSE BARB TEE   | 300     | 10/BAG  |
| M220200HBT    | 2" FULL PORT FLANGE X 2" HOSE BARB TEE | 300     | 10/BAG  |
| M300300HBT    | 3" FLANGE X 3" HOSE BARB TEE           | 150     | 1       |



Rib keeps gasket in place during assembly.



# MANIFOLD FLANGE CONNECTIONS

## FITTINGS

### FEATURES

- Quick and easy assembly
- Positive seals
- Easy on/off hose connections
- 360° orientation
- Parts must be ordered in lot quantities.

| BOLTED FLANGE CLAMPS |                                  |            |     |
|----------------------|----------------------------------|------------|-----|
| PART NO              | DESCRIPTION                      | TORQUE     | QTY |
| FC220B               | 2" FULL PORT BOLTED FLANGE CLAMP | 150 IN/LBS | 1   |
| FC300B               | 3" BOLTED FLANGE CLAMP           | 150 IN/LBS | 1   |

| T-BOLT FLANGE CLAMPS |  |            |        |
|----------------------|--|------------|--------|
| PART NO              | DESCRIPTION                                | TORQUE     | QTY    |
| FC220TB              | 2" FULL PORT HI-TORQUE T-BOLT FLANGE CLAMP | 100 IN/LBS | 10/BAG |
| FC300TB              | 3" FULL PORT HI-TORQUE T-BOLT FLANGE CLAMP | 100 IN/LBS | 1      |

| FLANGE CLAMPS |                             |               |        |
|---------------|-----------------------------|---------------|--------|
| PART NO       | DESCRIPTION                 | TORQUE        | QTY    |
| FC100         | 100 SERIES WORM SCREW CLAMP | 50-60 IN/LBS  | 10/BAG |
| FC200         | 200 SERIES WORM SCREW CLAMP | 90-100 IN/LBS | 10/BAG |
| FC220         | 220 SERIES WORM SCREW CLAMP | 90-100 IN/LBS | 10/BAG |
| FC300         | 300 SERIES WORM SCREW CLAMP | 90-100 IN/LBS | 10/BAG |

| GASKETS |   |                 |         |
|---------|---|-----------------|---------|
| PART NO | DESCRIPTION                                   | GASKET MATERIAL | LOT QTY |
| M100G   | 100 SERIES MANIFOLD GASKET                    | EPDM            | 25      |
| M101G   | 100 SERIES MANIFOLD GASKET WITH RIB           | EPDM            | 35      |
| M102G   | 1" & 1 1/4" SKIRTED FLANGE GASKET             | EPDM            | 1       |
| M100GV  | 100 SERIES GASKET                             | FKM             | 10      |
| 75GV    | 3/4" FKM GASKET                               | FKM             | 10      |
| 150G    | 200 SERIES GASKET                             | EPDM            | 25      |
| 150GV   | 200 SERIES GASKET                             | FKM             | 10      |
| 200G    | 220 SERIES FULL PORT GASKET                   | EPDM            | 25      |
| 200GV   | 220 SERIES FULL PORT GASKET                   | FKM             | 10      |
| M201G   | 200 SERIES MANIFOLD GASKET WITH RIB           | EPDM            | 30      |
| M202G   | 1 1/2" SKIRTED FLANGE GASKET                  | EPDM            | 1       |
| M221G   | 220 SERIES FULL PORT MANIFOLD GASKET WITH RIB | EPDM            | 30      |
| M222G   | 2" SKIRTED FLANGE GASKET                      | EPDM            | 1       |
| 300G    | 300 SERIES GASKET                             | EPDM            | 25      |
| 300GV   | 300 SERIES GASKET                             | FKM             | 10      |
| M301G   | 300 SERIES MANIFOLD GASKET WITH RIB           | EPDM            | 50      |
| M302G   | 3" SKIRTED FLANGE GASKET                      | EPDM            | 1       |

| MINI T STRAINERS |   |         |     |
|------------------|---|---------|-----|
| PART NO          | DESCRIPTION                                   | MAX PSI | QTY |
| MLSTM100-80      | 1" MANIFOLD MINI T STRAINER 80 MESH           | 300     | 1   |
| MLSTM100HB       | 1" MANIFOLD MINI T STRAINER HEAD & BOWL       | N/A     | 1   |
| MLSTM100HBC      | 1" MANIFOLD MINI T STRAINER HEAD & CLEAR BOWL | N/A     | 1   |

## MINI T LINE STRAINERS

### FEATURES

- Heavy duty glass reinforced polypropylene
- Clear bowl made of polycarbonate
- EPDM gaskets standard



# MANIFOLD FLANGE CONNECTIONS

## 1"-2" T LINE STRAINERS

### FEATURES

- EPDM gaskets STD
- Poly ribbed 316 stainless steel screens
- FKM gasket options as noted "V" suffix



| 1" FULL PORT MANIFOLD T LINE STRAINERS WITH MOUNTING TUBES |   |         |     |  |
|--|---|---------|-----|--|
| PART NO  | DESCRIPTION   | MAX PSI | QTY |  |
| MLST100-30   | 1" MANIFOLD T STRAINER W/30 MESH SCREEN                   | 300     | 1   |  |
| MLST100-50   | 1" MANIFOLD T STRAINER W/50 MESH SCREEN                   | 300     | 1   |  |
| MLST100-80   | 1" MANIFOLD T STRAINER W/80 MESH SCREEN                   | 300     | 1   |  |
| MLST100-100  | 1" MANIFOLD T STRAINER W/100 MESH SCREEN                  | 300     | 1   |  |
| MLST100-80V  | 1" MANIFOLD T STRAINER W/ 80 MESH SCREEN WITH FKM GASKETS | 300     | 1   |  |

| 2" STANDARD PORT MANIFOLD T LINE STRAINERS WITH MOUNTING TUBES |  |         |     |  |
|--|--|---------|-----|--|
| PART NO  | DESCRIPTION  | MAX PSI | QTY |  |
| MLST150-30   | 2" MANIFOLD T STRAINER W/30 MESH SCREEN                  | 225     | 1   |  |
| MLST150-50   | 2" MANIFOLD T STRAINER W/50 MESH SCREEN                  | 225     | 1   |  |
| MLST150-80   | 2" MANIFOLD T STRAINER W/80 MESH SCREEN                  | 225     | 1   |  |
| MLST150-80V  | 2" MANIFOLD T STRAINER W/80 MESH SCREEN WITH FKM GASKETS | 225     | 1   |  |
| MLST150-100  | 2" MANIFOLD T STRAINER W/100 MESH SCREEN                 | 225     | 1   |  |

## 1"-2" Y LINE STRAINERS

### FEATURES

- EPDM gaskets
- Poly ribbed 316 stainless steel screens



| 1" FULL PORT MANIFOLD Y LINE STRAINERS WITH MOUNTING TUBES |   |         |     |  |
|--|---|---------|-----|--|
| PART NO  | DESCRIPTION                             | MAX PSI | QTY |  |
| MLS100-80  | 1" MANIFOLD Y STRAINER W/80 MESH SCREEN | 225     | 1   |  |

| 2" STANDARD PORT MANIFOLD Y LINE STRAINERS WITH MOUNTING TUBES |   |         |     |  |
|--|---|---------|-----|--|
| PART NO  | DESCRIPTION                             | MAX PSI | QTY |  |
| MLS200-20M   | 2" MANIFOLD Y STRAINER W/20 MESH SCREEN | 225     | 1   |  |
| MLS200-50M   | 2" MANIFOLD Y STRAINER W/50 MESH SCREEN | 225     | 1   |  |
| MLS200-80M   | M200 Y STRAINER W/ MOUNT 80 MESH        | 225     | 1   |  |

| 2" STANDARD PORT MANIFOLD Y LINE STRAINERS |   |         |     |  |
|--|---|---------|-----|--|
| PART NO                                    | DESCRIPTION                             | MAX PSI | QTY |  |
| MLS200-12                                  | 2" MANIFOLD Y STRAINER W/12 MESH SCREEN | 225     | 1   |  |
| MLS200-20                                  | 2" MANIFOLD Y STRAINER W/20 MESH SCREEN | 225     | 1   |  |
| MLS200-50                                  | 2" MANIFOLD Y STRAINER W/50 MESH SCREEN | 225     | 1   |  |
| MLS200-80                                  | 2" MANIFOLD Y STRAINER W/80 MESH SCREEN | 225     | 1   |  |

## Y LINE STRAINERS

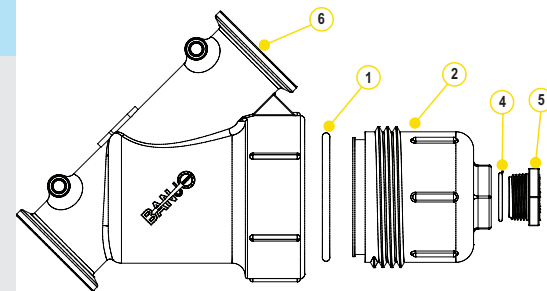

| REPLACEMENT PARTS 2" |           |                                 |     |  |
|----------------------|-----------|---------------------------------|-----|--|
| ITEM                 | PART NO   | DESCRIPTION                     | QTY |  |
| 1                    | LS150-G   | 2" EPDM GASKET                  | 1   |  |
| 2                    | LS150-C   | 2" Y BOWL, DRAIN PLUG, O-RING   | 1   |  |
| 3                    | LSQ200-PL | 2" PLUG                         | 1   |  |
| 4                    | LSQ200-R  | O-RING                          | 1   |  |
| 5                    | LST225D   | DECAL                           | 1   |  |
| 6                    | MLS200BB  | 2" MANIFOLD Y STRAINER BODY     | 1   |  |
| KIT                  | MLS200BCM | 2" FLANGE Y STRAINER BODY & CAP | 1   |  |

# MANIFOLD FLANGE CONNECTIONS

## T LINE STRAINERS

### SCREENS

| MESH SIZE | RIB COLOR     |
|-----------|---------------|
| 16 MESH   | BROWN RED     |
| 30 MESH   | FLAME RED     |
| 50 MESH   | GENTIAN BLUE  |
| 80 MESH   | ZINC YELLOW   |
| 100 MESH  | TRAFFIC GREEN |

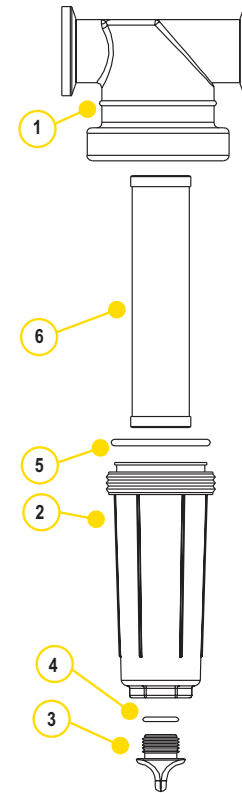

| REPLACEMENT PARTS 1" |            |                               |     |  |
|----------------------|------------|-------------------------------|-----|--|
| ITEM                 | PART NO    | DESCRIPTION                   | QTY |  |
| 1                    | MLST100-H  | 1" T BODY                     | 1   |  |
| 2                    | LST100-B   | 1" T BOWL, DRAIN PLUG, O-RING | 1   |  |
| 3                    | 12777      | 1/2" PLUG                     | 1   |  |
| 4                    | UV15163    | O-RING                        | 1   |  |
| 5                    | LST100-G   | 1" EPDM GASKET                | 1   |  |
| 5                    | LST100-GV  | 1" FKM GASKET                 | 1   |  |
| 6                    | LST116     | 16 MESH SCREEN                | 1   |  |
| 6                    | LST130     | 30 MESH SCREEN                | 1   |  |
| 6                    | LST150     | 50 MESH SCREEN                | 1   |  |
| 6                    | LST180     | 80 MESH SCREEN                | 1   |  |
| 6                    | LST1100    | 100 MESH SCREEN               | 1   |  |
| KIT                  | MLST100-HB | KIT INCLUDES ITEMS 1-5        | 1   |  |

| REPLACEMENT PARTS 2" |            |                                   |     |  |
|----------------------|------------|-----------------------------------|-----|--|
| ITEM                 | PART NO    | DESCRIPTION                       | QTY |  |
| 1                    | MLST150-H  | 1 1/2" T BODY                     | 1   |  |
| 2                    | LST150-B   | 1 1/2" T BOWL, DRAIN PLUG, O-RING | 1   |  |
| 3                    | LSQ200-PL  | 1 1/2" PLUG                       | 1   |  |
| 4                    | LSQ200-R   | O-RING                            | 1   |  |
| 5                    | LST150-G   | 1 1/2" EPDM GASKET                | 1   |  |
| 5                    | LST150-GV  | 1 1/2" FKM GASKET                 | 1   |  |
| 6                    | LST1516    | 16 MESH SCREEN                    | 1   |  |
| 6                    | LST1530    | 30 MESH SCREEN                    | 1   |  |
| 6                    | LST1550    | 50 MESH SCREEN                    | 1   |  |
| 6                    | LST1580    | 80 MESH SCREEN                    | 1   |  |
| 6                    | LST15100   | 100 MESH SCREEN                   | 1   |  |
| KIT                  | MLST150-HB | KIT INCLUDES ITEMS 1-5            | 1   |  |

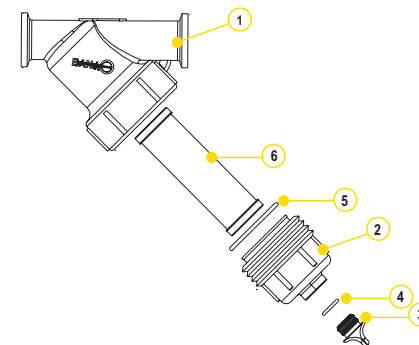

| REPLACEMENT PARTS 1" |          |                               |     |  |
|----------------------|----------|-------------------------------|-----|--|
| ITEM                 | PART NO  | DESCRIPTION                   | QTY |  |
| 1                    | MLS100B  | 1" Y BODY                     | 1   |  |
| 2                    | LS100-C1 | 1" Y BOWL, DRAIN PLUG, O-RING | 1   |  |
| 3                    | 12777    | 1/2" PLUG                     | 1   |  |
| 4                    | UV15163  | O-RING                        | 1   |  |
| 5                    | LS100-G  | 1" EPDM GASKET                | 1   |  |
| 6                    | LS120    | 20 MESH SCREEN                | 1   |  |
| 6                    | LS140    | 40 MESH SCREEN                | 1   |  |
| 6                    | LS180    | 80 MESH SCREEN                | 1   |  |
| KIT                  | MLS100BC | KIT INCLUDES ITEMS 1-5        | 1   |  |

| REPLACEMENT PARTS 2" |           |                               |     |  |
|----------------------|-----------|-------------------------------|-----|--|
| ITEM                 | PART NO   | DESCRIPTION                   | QTY |  |
| 1                    | MLS200B   | 2" Y BODY                     | 1   |  |
| 2                    | LS150-C   | 2" Y BOWL, DRAIN PLUG, O-RING | 1   |  |
| 3                    | LSQ200-PL | 2" PLUG                       | 1   |  |
| 4                    | LSQ200-R  | O-RING                        | 1   |  |
| 5                    | LS150-G   | 2" EPDM GASKET                | 1   |  |
| 5                    | LS150-GV  | 2" FKM GASKET                 | 1   |  |
| 6                    | LS206     | 6 MESH SCREEN                 | 1   |  |
| 6                    | LS212     | 12 MESH SCREEN                | 1   |  |
| 6                    | LS220     | 20 MESH SCREEN                | 1   |  |
| 6                    | LS230     | 30 MESH SCREEN                | 1   |  |
| 6                    | LS250     | 50 MESH SCREEN                | 1   |  |
| 6                    | LS280     | 80 MESH SCREEN                | 1   |  |
| 6                    | LS2120    | 120 MESH SCREEN               | 1   |  |
| KIT                  | MLS200BC  | KIT INCLUDES ITEMS 1-5        | 1   |  |

## Y LINE STRAINERS

### SCREENS

| MESH SIZE | RIB COLOR     |
|-----------|---------------|
| 6 MESH    | WHITE         |
| 12 MESH   | BLACK         |
| 20 MESH   | BEIGE         |
| 30 MESH   | FLAME RED     |
| 40 MESH   | BROWN         |
| 50 MESH   | GENTIAN BLUE  |
| 80 MESH   | ZINC YELLOW   |
| 100 MESH  | TRAFFIC GREEN |
| 120 MESH  | BLACK         |

# MANIFOLD FLANGE CONNECTIONS

## 2" FULL PORT Y LINE STRAINERS

### FEATURES

- EPDM gaskets
- 316 stainless steel screens



### 2" FULL PORT MANIFOLD Y LINE STRAINERS

| PART NO    | DESCRIPTION                                       | MAX PSI | QTY |
|------------|---|---------|-----|
| MLS222-04  | 2" FULL PORT MANIFOLD Y STRAINER W/4 MESH SCREEN  | 225     | 1   |
| MLS222-10  | 2" FULL PORT MANIFOLD Y STRAINER W/12 MESH SCREEN | 225     | 1   |
| MLS222-16  | 2" FULL PORT MANIFOLD Y STRAINER W/16 MESH SCREEN | 225     | 1   |
| MLS222-30  | 2" FULL PORT MANIFOLD Y STRAINER W/30 MESH SCREEN | 225     | 1   |
| MLS222-50  | 2" FULL PORT MANIFOLD Y STRAINER W/50 MESH SCREEN | 225     | 1   |
| MLS222-80  | 2" FULL PORT MANIFOLD Y STRAINER W/80 MESH SCREEN | 225     | 1   |
| MLS222-30V | 2" FULL PORT MANIFOLD Y STRAINER W 30 MESH SCREEN | 225     | 1   |

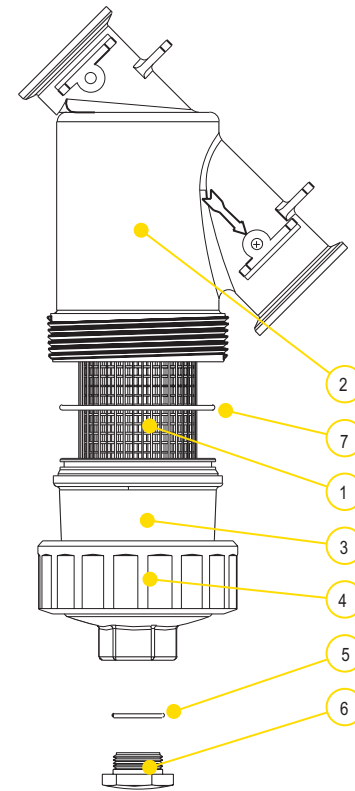

# MANIFOLD FLANGE CONNECTIONS

## 2" FULL PORT Y LINE STRAINERS

### FEATURES

- EPDM gaskets
- 316 stainless steel screens

### REPLACEMENT PARTS 2"

| ITEM | PART NO   | DESCRIPTION                   | QTY |
|------|-----------|-------------------------------|-----|
| 1    | LST204SS  | 4 SS MESH SCREEN              | 1   |
| 1    | LST206SS  | 6 SS MESH SCREEN              | 1   |
| 1    | LST208SS  | 8 SS MESH SCREEN              | 1   |
| 1    | LST210SS  | 10 SS MESH SCREEN             | 1   |
| 1    | LST216SS  | 16 SS MESH SCREEN             | 1   |
| 1    | LST230SS  | 30 SS MESH SCREEN             | 1   |
| 1    | LST250SS  | 50 SS MESH SCREEN             | 1   |
| 1    | MLS250SS  | 50 SS MESH PERFORATED SCREEN  | 1   |
| 1    | LST280SS  | 80 SS MESH SCREEN             | 1   |
| 1    | MLS280SS  | 80 SS MESH PERFORATED SCREEN  | 1   |
| 1    | LST2100SS | 100 SS MESH SCREEN            | 1   |
| 1    | MLS2100SS | 100 SS MESH PERFORATED SCREEN | 1   |
| 2    | MLS222B   | 2" FLANGED Y STRAINER BODY    | 1   |
| 3    | MLS220C1  | 2" FLANGED Y STRAINER CAP     | 1   |
| 4    | MLS220R1  | 2" FLANGED Y STRAINER RING    | 1   |
| 5    | LSQ200-R  | 2" PLUG GASKET                | 1   |
| 6    | LSQ200-PL | 2" PLUG                       | 1   |
| 7    | MLS220G1  | 2" BODY GASKET                | 1   |
| 2-7  | MLS222BC  | STRAINER WITHOUT SCREEN       | 1   |

## 3" Y LINE STRAINERS

### FEATURES

- EPDM gaskets
- 304 stainless steel screens
- Must use on suction side or non-pressure side in all applications

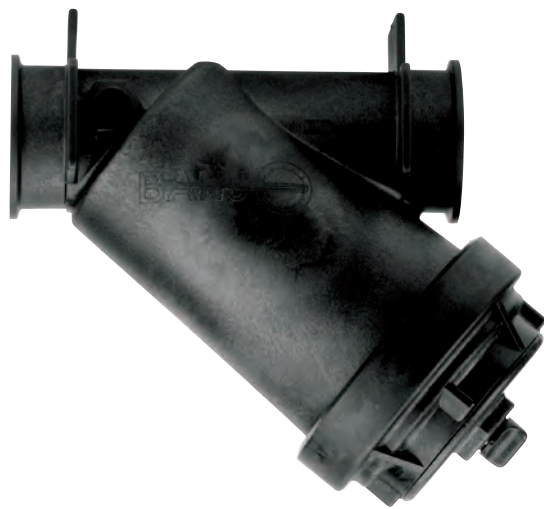

### 3" FULL PORT MANIFOLD Y LINE STRAINERS

| PART NO    | DESCRIPTION                             | MAX PSI | LOT QTY |
|------------|---|---------|---------|
| MLS300-12  | 3" MANIFOLD Y STRAINER W/12 MESH SCREEN | 100     | 1       |
| MLS300-20  | 3" MANIFOLD Y STRAINER W/20 MESH SCREEN | 100     | 1       |
| MLS300-50  | 3" MANIFOLD Y STRAINER W/50 MESH SCREEN | 100     | 1       |
| MLS300-20V | 3" MANIFOLD Y STRAINER W/20 MESH SCREEN | 100     | 1       |

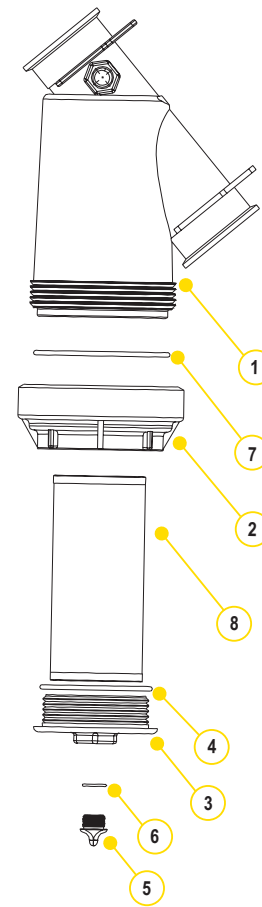

## 3" Y LINE STRAINERS

### FEATURES

- EPDM gaskets
- 304 stainless steel screens
- Must use on suction side or non-pressure side in all applications

### REPLACEMENT PARTS 3"

| ITEM | PART NO    | DESCRIPTION                | QTY |
|------|------------|----------------------------|-----|
| 1    | MLS300B    | 3" FLANGED Y STRAINER BODY | 1   |
| 2    | MLS300CAP  | 3" FLANGED Y STRAINER CAP  | 1   |
| 3    | LS300EC    | 3" END CAP                 | 1   |
| 4    | MLS300ECG  | 3" EPDM END CAP GASKET     | 1   |
| 4    | MLS300ECGV | 3" FKM END CAP GASKET      | 1   |
| 5    | 13777      | 3/4" PLUG                  | 1   |
| 6    | 13778      | O-RING                     | 1   |
| 7    | MLS300G    | 3" EPDM CAP GASKET         | 1   |
| 8    | LS304      | 4 SS MESH SCREEN           | 1   |
| 8    | LS308      | 8 SS MESH SCREEN           | 1   |
| 8    | LS312      | 12 SS MESH SCREEN          | 1   |
| 8    | LS320      | 20 SS MESH SCREEN          | 1   |
| 8    | LS350      | 50 SS MESH SCREEN          | 1   |
| 1-7  | MLS300BC   | STRAINER WITHOUT SCREEN    | 1   |



## BOTTOM DRAIN BOLTED TANK FITTINGS

### FEATURES

- Stainless steel bolts
- Bolt head plugs sealed ultrasonically
- Glass reinforced polypropylene
- EPDM gasket standard
- FKM gasket available



### BOTTOM DRAIN BOLTED TANK FITTINGS

| PART NO  | DESCRIPTION                                   | MAX PSI | LOT QTY |
|----------|---|---------|---------|
| MBF100BD | 1" FLANGE X 1" FEMALE THREAD W/EPDM GASKET    | 150     | 5       |
| MBF200BD | 2" FLANGE X 2" FEMALE THREAD W/EPDM GASKET    | 150     | 5       |
| MBF220BD | 2" FP FLANGE X 2" FEMALE THREAD W/EPDM GASKET | 150     | 5       |
| MBF300BD | 3" FLANGE X 3" FEMALE THREAD W/EPDM GASKET    | 150     | 8       |

## BOTTOM DRAIN BULKHEAD FITTINGS

### FEATURES

- Glass reinforced polypropylene
- EPDM standard
- Groove allows more drainage
- Gasket not included



### BOTTOM DRAIN BULKHEAD FITTINGS

| PART NO  | DESCRIPTION                                   | HOLE SIZE | MAX PSI | LOT QTY |
|----------|---|-----------|---------|---------|
| MTF100BD | 1" FLANGE X 1" FEMALE THREAD W/EPDM GASKET    | 2 1/4"    | 300     | 10      |
| MTF220BD | 2" FP FLANGE X 2" FEMALE THREAD W/EPDM GASKET | 3 1/4"    | 300     | 10      |
| MTF300BD | 3" FLANGE X 3" FEMALE THREAD W/EPDM GASKET    | 4 1/2"    | 200     | 1       |

## BOLTED TANK FITTINGS

### FEATURES

- Stainless steel bolts
- Bolt head plugs sealed ultrasonically
- Glass reinforced polypropylene
- EPDM gasket standard
- FKM gasket available



### BOLTED TANK FITTINGS

| PART NO | DESCRIPTION                                   | MAX PSI | LOT QTY |
|---------|---|---------|---------|
| MBF100  | 1" FLANGE X 1" FEMALE THREAD W/EPDM GASKET    | 150     | 5       |
| MBF200  | 2" FLANGE X 2" FEMALE THREAD W/EPDM GASKET    | 150     | 5       |
| MBF220  | 2" FP FLANGE X 2" FEMALE THREAD W/EPDM GASKET | 150     | 5       |
| MBF300  | 3" FLANGE X 3" FEMALE THREAD W/EPDM GASKET    | 150     | 5       |



## MAX WALL THICKNESS CHART ON PAGE 160

## NOT YOUR TYPICAL SPILLAGE

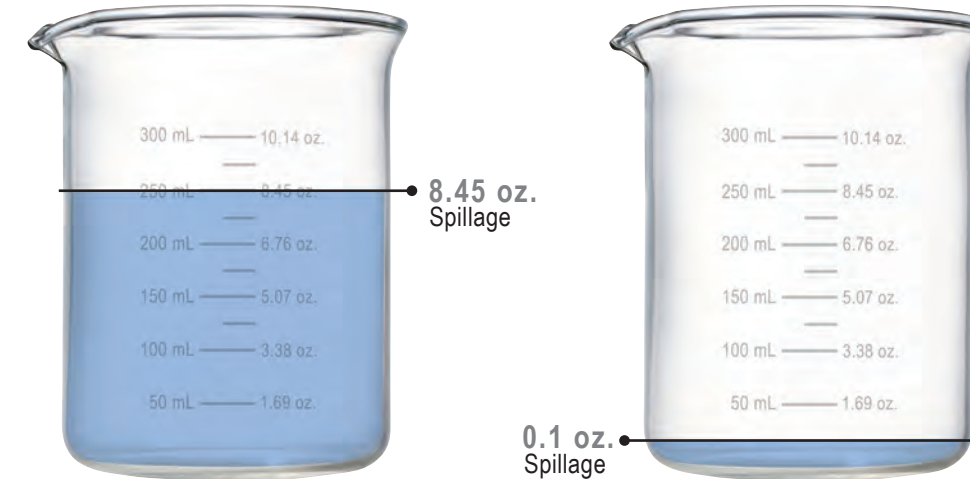

STANDARD 2" VALVE

2" DRY-MATE

### 99% SPILLAGE REDUCTION

- Reduction of typical spillage using standard 2" valve with cam lock connection vs. Dry-Mate
- 8.45 oz. (250 mL) vs. 0.1 oz. (3 mL) spillage
- At five disconnections per day, this is **over 118 gallons (450 liters) saved per year**; enough to fill the gas tanks of eight mid-size automobiles

### FEATURES



### SAFETY FIRST

Product is important, but the safety of your team is essential. With Dry-Mate Dry-Disconnects, leakage from disconnecting is miniscule compared to standard valves. When properly installed and operated, the danger posed by harmful chemicals contacting your team is greatly reduced.



### EVERY DROP COUNTS

Your product is money. Why waste money in spilling your product every time you disconnect? With Dry-Mate, your spillage amount will be significantly reduced. At 3 mL product spillage for a 2" line, you can have peace of mind that your product is being placed where it should be and not on the ground.



### PRODUCT ONLY WHERE YOU WANT IT

When a Dry-Mate is properly installed and operated, the assembly will not accidentally separate while fluid is flowing; preventing costly mishaps.



### DITCH THE MAINTENANCE

All that spillage has to go somewhere. If you are collecting large areas of spillage run-off, you have to have it pumped out. Reduce your maintenance costs on your spillage pits by keeping fluids contained.

## 1½" POLY DRY-MATES

### FEATURES

- Lightweight
- Easy to use
- Economical
- Reduces risk of exposure
- Wide range of chemical resistance
- Unrestricted 1½" flow
- Patented double ball design with cam lever connection
- When properly installed and operated, the assembly will not accidentally separate while fluid is flowing; preventing costly mishaps
- Spillage data: 1½" = 2ml



### REPAIR KIT INCLUDES:

- Ball
- Body gasket
- Thrust washer
- Ball seats
- Upper stem bushing
- Stem o-ring

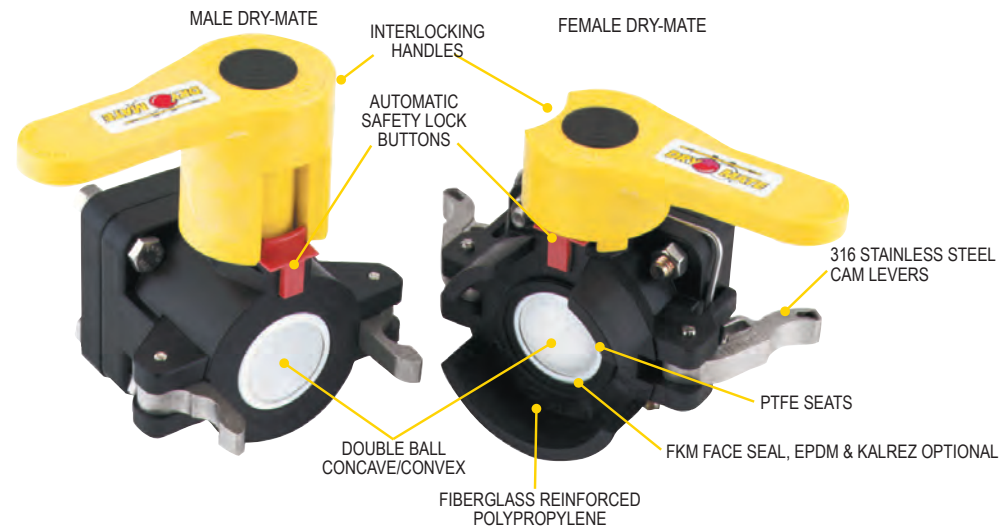

| 1½" POLY MALE DRY-MATE |                                 |         |           |                   |     |
|------------------------|---------------------------------|---------|-----------|-------------------|-----|
| PART NO                | DESCRIPTION                     | MAX PSI | PIPE SIZE | OPENING THRU BALL | QTY |
| DM150A                 | 1½" MALE X FPT NPT W/FKM SEALS  | 100     | 1½"       | 1½"               | 1   |
| DM150AB                | 1½" MALE X FPT BSP W/FKM SEALS  | 100     | 1½"       | 1½"               | 1   |
| DM150AE                | 1½" MALE X FPT NPT W/EPDM SEALS | 100     | 1½"       | 1½"               | 1   |

| 1½" POLY FEMALE DRY-MATE |                                   |         |           |                   |     |
|--------------------------|-----------------------------------|---------|-----------|-------------------|-----|
| PART NO                  | DESCRIPTION                       | MAX PSI | PIPE SIZE | OPENING THRU BALL | QTY |
| DM150D                   | 1½" FEMALE X FPT NPT W/FKM SEALS  | 100     | 1½"       | 1½"               | 1   |
| DM150DB                  | 1½" FEMALE X FPT BSP W/FKM SEALS  | 100     | 1½"       | 1½"               | 1   |
| DM150DE                  | 1½" FEMALE X FPT NPT W/EPDM SEALS | 100     | 1½"       | 1½"               | 1   |

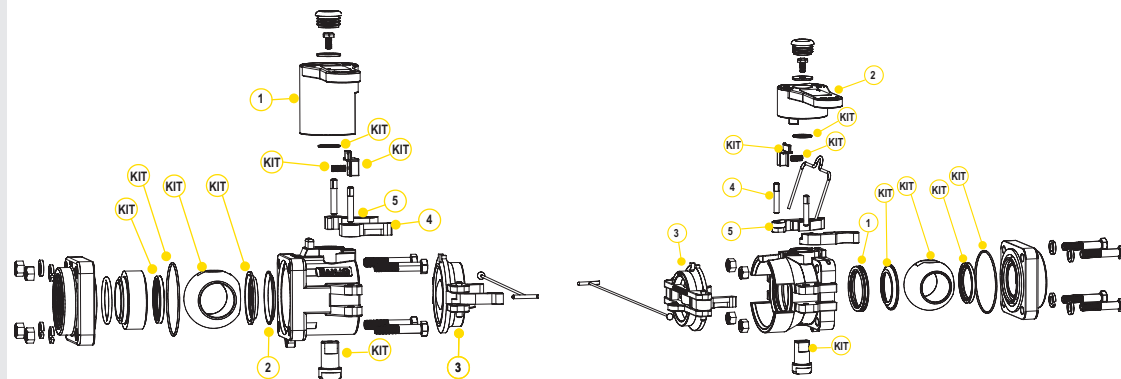

| REPLACEMENT PARTS MALE |          |                       |     |
|------------------------|----------|-----------------------|-----|
| ITEM                   | PART NO  | DESCRIPTION           | QTY |
| 1                      | DM20153M | MALE HANDLE           | 1   |
| 1                      | DB20153M | LOW PROFILE HANDLE    | 1   |
| 2                      | DB20290  | FKM FACE SEAL         | 1   |
| 2                      | DB20295  | EPDM FACE SEAL        | 1   |
| 2                      | DM20296  | KALREZ® FACE SEAL     | 1   |
| 3                      | DM200CAP | DUST CAP              | 1   |
| 4                      | DM20300  | PROFILE INSERT        | 2   |
| 5                      | 200P     | PIN                   | 2   |
| KIT                    | DM20200A | REPAIR KIT FOR DM150A | 1   |

| REPLACEMENT PARTS FEMALE |          |                       |     |
|--------------------------|----------|-----------------------|-----|
| ITEM                     | PART NO  | DESCRIPTION           | QTY |
| 1                        | DM20294A | FKM FACE SEAL         | 1   |
| 1                        | D20295A  | EPDM FACE SEAL        | 1   |
| 1                        | DM20296  | KALREZ® FACE SEAL     | 1   |
| 2                        | DM20153F | FEMALE HANDLE         | 1   |
| 3                        | DM200PL  | DUST PLUG             | 1   |
| 4                        | 200P     | PIN                   | 2   |
| 5                        | DM200KX  | CAM ARM               | 2   |
| KIT                      | DM20200D | REPAIR KIT FOR DM150D | 1   |

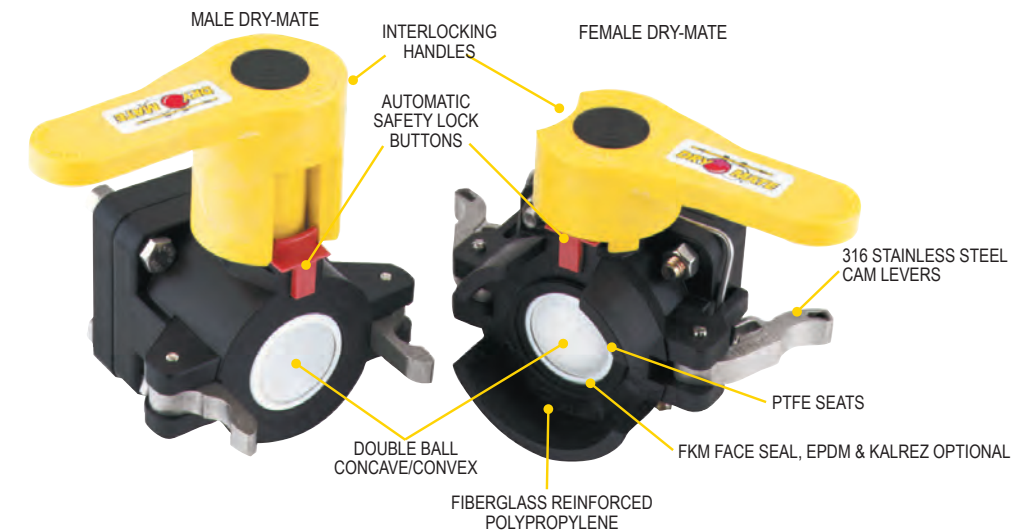

| 2" POLY MALE DRY-MATE |   |         |           |                   |     |
|-----------------------|---|---------|-----------|-------------------|-----|
| PART NO               | DESCRIPTION                             | MAX PSI | PIPE SIZE | OPENING THRU BALL | QTY |
| DM200A                | 2" MALE X FPT NPT W/FKM SEALS           | 100     | 2"        | 1½"               | 1   |
| DM200AB               | 2" MALE X FPT BSP W/FKM SEALS           | 100     | 2"        | 1½"               | 1   |
| DM200AE               | 2" MALE X FPT NPT W/EPDM SEALS          | 100     | 2"        | 1½"               | 1   |
| DM200AT               | 2" MALE X FPT NPT W/KALREZ® SEALS       | 100     | 2"        | 1½"               | 1   |
| DMMT201A              | 2" MALE X MALE NPT W/LOW PROFILE HANDLE | 100     | 2"        | 1½"               | 1   |

| 2" POLY FEMALE DRY-MATE |                                     |         |           |                   |     |
|-------------------------|-------------------------------------|---------|-----------|-------------------|-----|
| PART NO                 | DESCRIPTION                         | MAX PSI | PIPE SIZE | OPENING THRU BALL | QTY |
| DM200D                  | 2" FEMALE X FPT NPT W/FKM SEALS     | 100     | 2"        | 1½"               | 1   |
| DM200DB                 | 2" FEMALE X FPT BSP W/FKM SEALS     | 100     | 2"        | 1½"               | 1   |
| DM200DE                 | 2" FEMALE W/EPDM SEALS              | 100     | 2"        | 1½"               | 1   |
| DM200DT                 | 2" FEMALE X FPT NPT W/KALREZ® SEALS | 100     | 2"        | 1½"               | 1   |

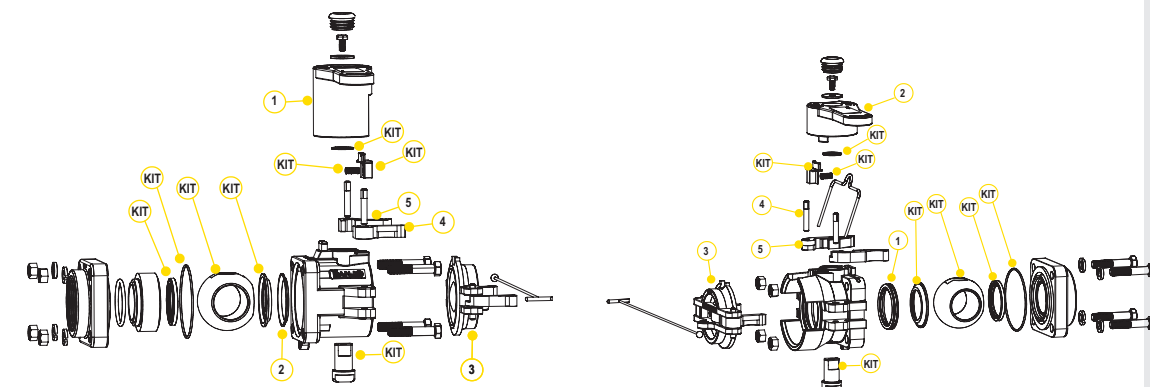

| REPLACEMENT PARTS MALE |          |                                 |     |
|------------------------|----------|---------------------------------|-----|
| ITEM                   | PART NO  | DESCRIPTION                     | QTY |
| 1                      | DM20153M | MALE HANDLE                     | 1   |
| 1                      | DB20153M | LOW PROFILE HANDLE              | 1   |
| 2                      | DB20290  | FKM FACE SEAL                   | 1   |
| 2                      | DB20295  | EPDM FACE SEAL                  | 1   |
| 2                      | DM20296  | KALREZ® FACE SEAL               | 1   |
| 3                      | DM200CAP | DUST CAP                        | 1   |
| 4                      | DM20300  | PROFILE INSERT                  | 2   |
| 5                      | 200P     | PIN                             | 2   |
| KIT                    | DM20200A | REPAIR KIT FOR DM200A & DM200AE | 1   |

| REPLACEMENT PARTS FEMALE |          |                                 |     |
|--------------------------|----------|---------------------------------|-----|
| ITEM                     | PART NO  | DESCRIPTION                     | QTY |
| 1                        | DM20294A | FKM FACE SEAL                   | 1   |
| 1                        | DM20295A | EPDM FACE SEAL                  | 1   |
| 1                        | DM20296  | KALREZ® FACE SEAL               | 1   |
| 2                        | DM20153F | FEMALE HANDLE                   | 1   |
| 3                        | DM200PL  | DUST PLUG                       | 1   |
| 4                        | 200P     | PIN                             | 2   |
| 5                        | DM200KX  | CAM ARM                         | 2   |
| KIT                      | DM20200D | REPAIR KIT FOR DM200D & DM200DE | 1   |

## 2" POLY DRY-MATES

### FEATURES

- Lightweight
- Easy to use
- Economical
- Reduces risk of exposure
- Wide range of chemical resistance
- Unrestricted 1½" flow
- Patented double ball design with cam lever connection
- When properly installed and operated, the assembly will not accidentally separate while fluid is flowing; preventing costly mishaps
- Spillage data: 2" = 2.6ml



### REPAIR KIT INCLUDES:

- Ball
- Body gasket
- Thrust washer
- Ball seats
- Upper stem bushing
- Stem o-ring



## 2" FULL PORT POLY DRY-MATES

### FEATURES

- Lightweight
- Easy to use
- Economical
- Reduces risk of exposure
- Wide range of chemical resistance
- Unrestricted 2" flow
- Patented double ball design with cam lever connection
- When properly installed and operated, the assembly will not accidentally separate while fluid is flowing; preventing costly mishaps
- Spillage data: 2" FP = 3.6ml



DM220D

DM220A

### 2" FULL PORT POLY DRY-MATES

| PART NO | DESCRIPTION                     | MAX PSI | PIPE SIZE | OPENING THRU BALL | QTY |
|---------|---------------------------------|---------|-----------|-------------------|-----|
| DM220D  | 2" FEMALE X FPT NPT W/FKM SEALS | 225     | 2"        | 2"                | 1   |
| DM220A  | 2" MALE X FPT W/FKM SEALS       | 225     | 2"        | 2"                | 1   |



### REPAIR KIT INCLUDES:

- Body gasket
- Thrust washer
- Ball seats
- Upper stem bushing
- Stem o-ring
- Face seal

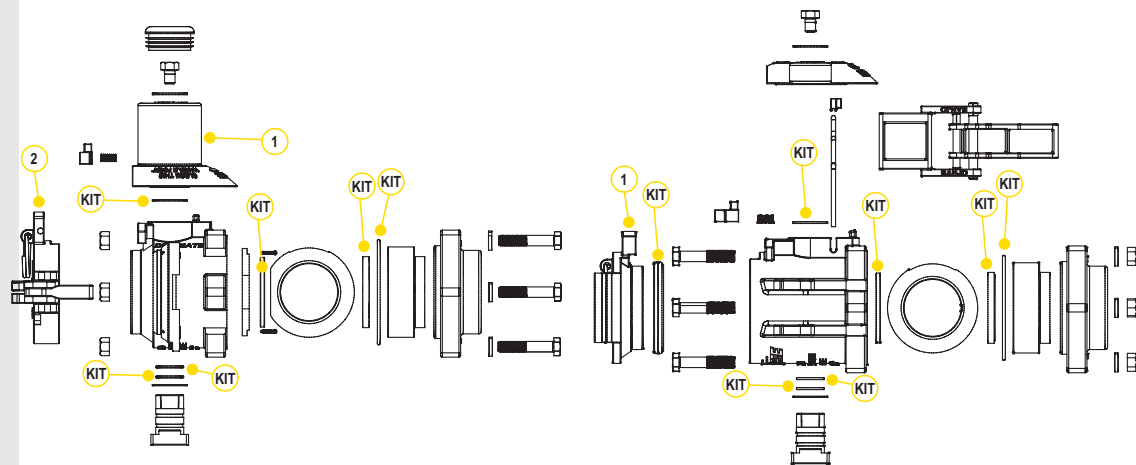

### REPLACEMENT PARTS MALE

| ITEM | PART NO  | DESCRIPTION | QTY |
|------|----------|-------------|-----|
| 1    | DM25153M | MALE HANDLE | 1   |
| 2    | DM220CAP | DUST CAP    | 1   |
| KIT  | DM25200  | REPAIR KIT  | 1   |

### REPLACEMENT PARTS FEMALE

| ITEM | PART NO  | DESCRIPTION   | QTY |
|------|----------|---------------|-----|
| 1    | DM25153F | FEMALE HANDLE | 1   |
| 2    | DM221PL  | DUST PLUG     | 1   |
| KIT  | DM25200  | REPAIR KIT    | 1   |



DM300DFP

DM300AFP

### 3" FULL PORT POLY DRY-MATES

| PART NO  | DESCRIPTION                                       | MAX PSI | PIPE SIZE | OPENING THRU BALL | QTY |
|----------|---|---------|-----------|-------------------|-----|
| DM300AFP | 3" FP MALE X 3" FEMALE NPT THREADS W/ FKM SEALS   | 150     | 3"        | 3"                | 1   |
| DM300DFP | 3" FP FEMALE X 3" FEMALE NPT THREADS W/ FKM SEALS | 150     | 3"        | 3"                | 1   |

## 3" FULL PORT POLY DRY-MATES

### FEATURES

- Lightweight
- Easy to use
- Economical
- Reduces risk of exposure
- Wide range of chemical resistance
- Unrestricted 3" flow
- Patented double ball design with cam lever connection
- When properly installed and operated, the assembly will not accidentally separate while fluid is flowing; preventing costly mishaps
- Spillage data: 3" = 20ml



### REPAIR KIT INCLUDES:

- Ball
- Body gasket
- Thrust washer
- Ball seats
- Upper stem bushing
- Stem o-ring
- Face seal

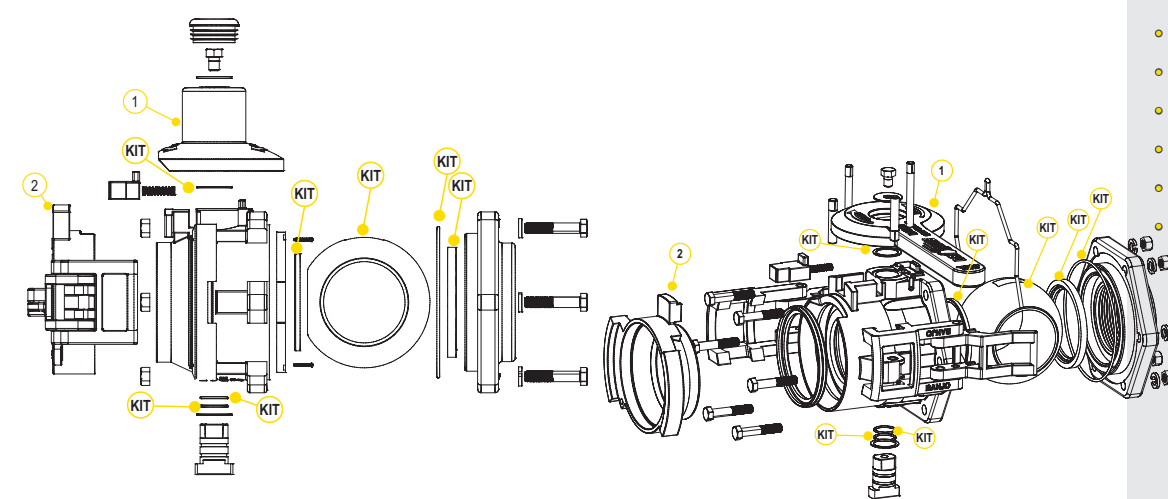

### REPLACEMENT PARTS MALE

| ITEM | PART NO  | DESCRIPTION | QTY |
|------|----------|-------------|-----|
| 1    | DM35153M | MALE HANDLE | 1   |
| 2    | DM300CAP | DUST CAP    | 1   |
| KIT  | DM35200  | REPAIR KIT  | 1   |

### REPLACEMENT PARTS FEMALE

| ITEM | PART NO  | DESCRIPTION   | QTY |
|------|----------|---------------|-----|
| 1    | DM35153F | FEMALE HANDLE | 1   |
| 2    | DM300PL  | DUST PLUG     | 1   |
| KIT  | DM35200  | REPAIR KIT    | 1   |

## 1" FULL PORT STAINLESS STEEL DRY-MATES

### FEATURES

- 316 stainless steel construction
- Unrestricted 1" flow
- Patented double ball design with cam lever connection
- 300°F maximum operating temperature
- 100% PTFE ball seats
- When properly installed and operated, the assembly will not accidentally separate while fluid is flowing; preventing costly mishaps
- Spillage data: 1" FP = 1.7ml



DM100ASS

DM100DSS

| 1" FULL PORT STAINLESS STEEL DRY-MATE |                                   |         |           |                   |     |
|---------------------------------------|-----------------------------------|---------|-----------|-------------------|-----|
| PART NO                               | DESCRIPTION                       | MAX PSI | PIPE SIZE | OPENING THRU BALL | QTY |
| DM100ASS                              | 1" MALE X FPT NPT W/ PTFE SEALS   | 150     | 1"        | 1"                | 1   |
| DM100ABSS                             | 1" MALE X BSPP W/ PTFE SEALS      | 150     | 1"        | 1"                | 1   |
| DM100DSS                              | 1" FEMALE X FPT NPT W/ FKM SEALS  | 150     | 1"        | 1"                | 1   |
| DM100DSSE                             | 1" FEMALE X FPT NPT W/ EPDM SEALS | 150     | 1"        | 1"                | 1   |
| DM100DBSS                             | 1" FEMALE X BSPP W/ FKM SEALS     | 150     | 1"        | 1"                | 1   |



### REPAIR KIT INCLUDES:

- Ball
- Body gasket
- Thrust washer
- Ball seats
- Upper stem bushing
- Stem o-ring
- Face seal

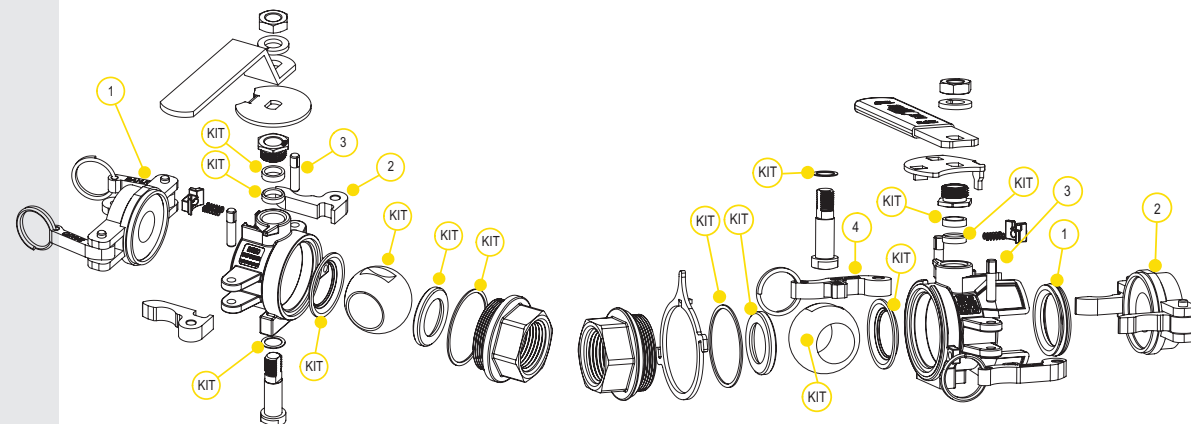

| REPLACEMENT PARTS MALE |          |                |     |
|------------------------|----------|----------------|-----|
| ITEM                   | PART NO  | DESCRIPTION    | QTY |
| 1                      | DM100CAP | DUST CAP       | 1   |
| 2                      | DM10300  | PROFILE INSERT | 2   |
| 3                      | 100P     | PIN            | 2   |
| KIT                    | DM101SS  | REPAIR KIT     | 1   |

| REPLACEMENT PARTS FEMALE |          |                   |     |
|--------------------------|----------|-------------------|-----|
| ITEM                     | PART NO  | DESCRIPTION       | QTY |
| 1                        | DM10294A | FKM FACE SEAL     | 1   |
| 1                        | DM10295A | EPDM FACE SEAL    | 1   |
| 1                        | DM10296  | KALREZ® FACE SEAL | 1   |
| 2                        | DM100PL  | POLY PLUG         | 1   |
| 3                        | 100P     | PIN               | 2   |
| 4                        | DM100K   | CAM ARM           | 2   |
| KIT                      | DM102SSV | FKM REPAIR KIT    | 1   |

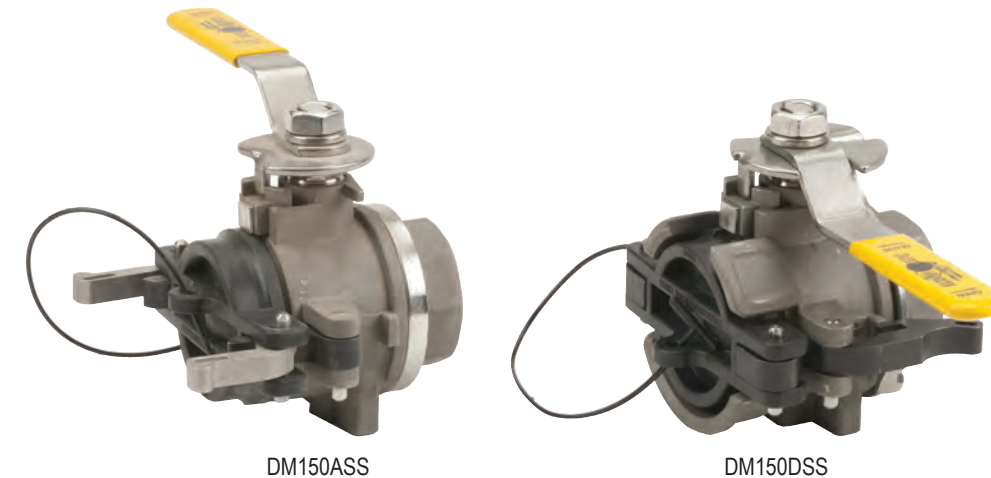

DM150ASS

DM150DSS

| 1 1/2" FULL PORT STAINLESS STEEL DRY-MATE |                                       |         |           |                   |     |
|---|---------------------------------------|---------|-----------|-------------------|-----|
| PART NO                                   | DESCRIPTION                           | MAX PSI | PIPE SIZE | OPENING THRU BALL | QTY |
| DM150ASS                                  | 1 1/2" MALE X FPT NPT W/ PTFE SEALS   | 150     | 1 1/2"    | 1 1/2"            | 1   |
| DM150ABSS                                 | 1 1/2" MALE X BSPP W/ PTFE SEALS      | 150     | 1 1/2"    | 1 1/2"            | 1   |
| DM150DSS                                  | 1 1/2" FEMALE X FPT NPT W/ FKM SEALS  | 150     | 1 1/2"    | 1 1/2"            | 1   |
| DM150DSSE                                 | 1 1/2" FEMALE X FPT NPT W/ EPDM SEALS | 150     | 1 1/2"    | 1 1/2"            | 1   |
| DM150DBSS                                 | 1 1/2" FEMALE X BSPP W/ FKM SEALS     | 150     | 1 1/2"    | 1 1/2"            | 1   |

## 1 1/2" FULL PORT STAINLESS STEEL DRY-MATES

### FEATURES

- 316 stainless steel construction
- Unrestricted 1 1/2" flow
- Patented double ball design with cam lever connection
- 300°F maximum operating temperature
- 100% PTFE ball seats
- When properly installed and operated, the assembly will not accidentally separate while fluid is flowing; preventing costly mishaps
- Spillage data: 1 1/2" FP = 3ml



### REPAIR KIT INCLUDES:

- Ball
- Body gasket
- Thrust washer
- Ball seats
- Upper stem bushing
- Stem o-ring
- Face seal

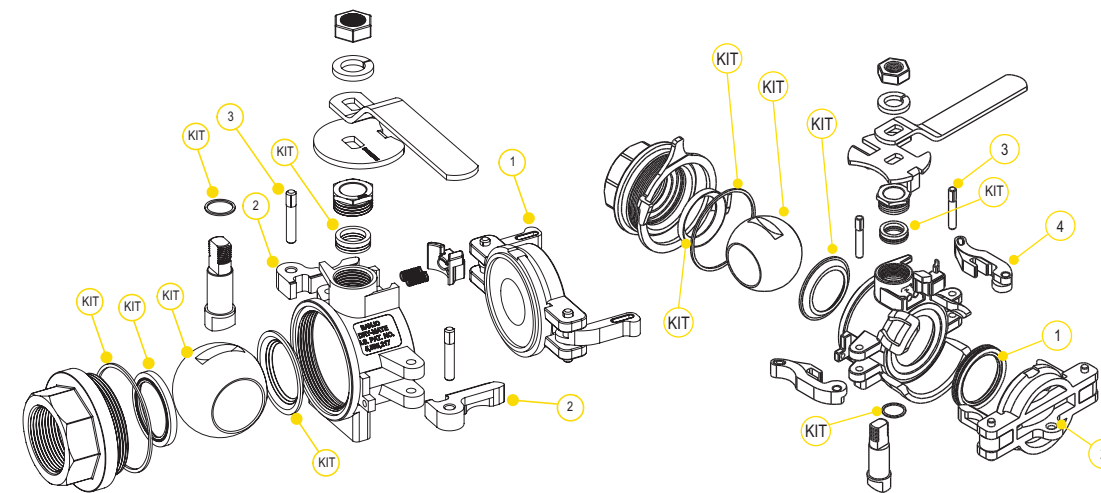

| REPLACEMENT PARTS MALE |           |                |     |
|------------------------|-----------|----------------|-----|
| ITEM                   | PART NO   | DESCRIPTION    | QTY |
| 1                      | DM200ACAP | DUST CAP       | 1   |
| 2                      | DM20300   | PROFILE INSERT | 2   |
| 3                      | 200P      | PIN            | 2   |
| KIT                    | DM201SS   | REPAIR KIT     | 1   |

| REPLACEMENT PARTS FEMALE |          |                   |     |
|--------------------------|----------|-------------------|-----|
| ITEM                     | PART NO  | DESCRIPTION       | QTY |
| 1                        | DM20294A | FKM FACE SEAL     | 1   |
| 1                        | DM20295A | EPDM FACE SEAL    | 1   |
| 1                        | DM20296  | KALREZ® FACE SEAL | 1   |
| 2                        | DM200APL | DUST PLUG         | 1   |
| 3                        | 200P     | PIN               | 2   |
| 4                        | DM200KX  | CAM ARM           | 2   |
| KIT                      | DM202SSV | FKM REPAIR KIT    | 1   |



## 2" STAINLESS STEEL DRY-MATES

### FEATURES

- 316 stainless steel construction
- Patented double ball design with cam lever connection
- 300°F maximum operating temperature
- 100% PTFE ball seats
- When properly installed and operated, the assembly will not accidentally separate while fluid is flowing; preventing costly mishaps
- Spillage data: 2" = 3.6ml



DM200ASS



DM200DSS

### 2" STANDARD PORT STAINLESS STEEL DRY-MATE

| PART NO   | DESCRIPTION                          | MAX PSI | PIPE SIZE | OPENING THRU BALL | QTY |
|-----------|--------------------------------------|---------|-----------|-------------------|-----|
| DM200ASS  | 2" MALE X FPT NPT W/ PTFE SEALS      | 150     | 2"        | 1½"               | 1   |
| DM200ABSS | 2" MALE X BSPP W/ PTFE SEALS         | 150     | 2"        | 1½"               | 1   |
| DM200DSS  | 2" FEMALE X FPT NPT W/ FKM SEALS     | 150     | 2"        | 1½"               | 1   |
| DM200DSST | 2" FEMALE X FPT NPT W/ KALREZ® SEALS | 150     | 2"        | 1½"               | 1   |
| DM200DBSS | 2" FEMALE X BSPP W/ FKM SEALS        | 150     | 2"        | 1½"               | 1   |



### REPAIR KIT INCLUDES:

- Ball
- Body gasket
- Thrust washer
- Ball seats
- Upper stem bushing
- Stem o-ring
- Face seal

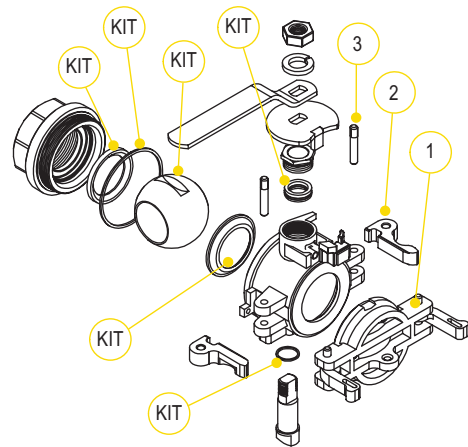

### REPLACEMENT PARTS MALE

| ITEM | PART NO   | DESCRIPTION    | QTY |
|------|-----------|----------------|-----|
| 1    | DM200ACAP | DUST CAP       | 1   |
| 2    | DM20300   | PROFILE INSERT | 2   |
| 3    | 200P      | PIN            | 2   |
| KIT  | DM201SS   | REPAIR KIT     | 1   |

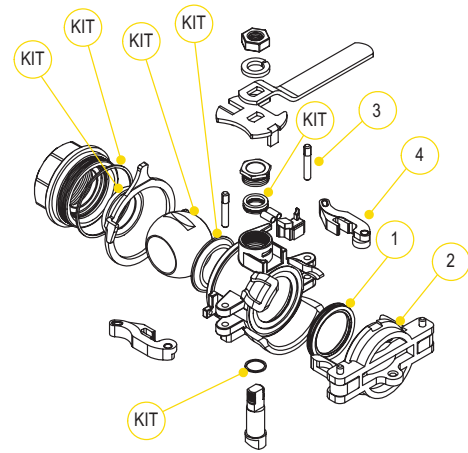

### REPLACEMENT PARTS FEMALE

| ITEM | PART NO  | DESCRIPTION       | QTY |
|------|----------|-------------------|-----|
| 1    | DM20294A | FKM FACE SEAL     | 1   |
| 1    | DM20295A | EPDM FACE SEAL    | 1   |
| 1    | DM20296  | KALREZ® FACE SEAL | 1   |
| 2    | DM200APL | POLY PLUG         | 1   |
| 3    | 200P     | PIN               | 2   |
| 4    | DM200KX  | CAM ARM           | 2   |
| KIT  | DM202SSV | FKM REPAIR KIT    | 1   |



DM220ABSS



DM220DBSS

### 2" FULL PORT STAINLESS STEEL DRY-MATE

| PART NO   | DESCRIPTION                                | MAX PSI | PIPE SIZE | OPENING THRU BALL | QTY |
|-----------|--|---------|-----------|-------------------|-----|
| DM220ASS  | 2" FULL PORT MALE X FPT NPT W/ PTFE SEALS  | 300     | 2"        | 2"                | 1   |
| DM220ABSS | 2" FULL PORT MALE X BSPP W/ PTFE SEALS     | 300     | 2"        | 2"                | 1   |
| DM220DSS  | 2" FULL PORT FEMALE X FPT NPT W/ FKM SEALS | 300     | 2"        | 2"                | 1   |
| DM220DBSS | 2" FULL PORT FEMALE X BSPP W/ FKM SEALS    | 300     | 2"        | 2"                | 1   |

## 2" FULL PORT STAINLESS STEEL DRY-MATES

### FEATURES

- 316 stainless steel construction
- Unrestricted 2" flow
- Patented double ball design with cam lever connection
- 300°F maximum operating temperature
- 100% PTFE ball seats
- When properly installed and operated, the assembly will not accidentally separate while fluid is flowing; preventing costly mishaps
- Spillage data: 2" FP = 3.8ml



### REPAIR KIT INCLUDES:

- Body gasket
- Thrust washer
- Ball seats
- Upper stem bushing
- Stem o-ring

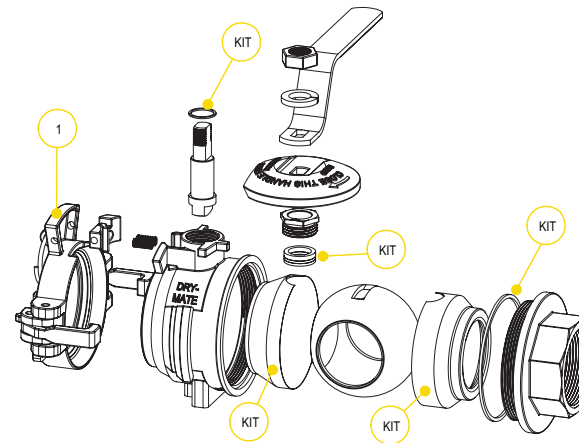

### REPLACEMENT PARTS MALE

| ITEM | PART NO  | DESCRIPTION | QTY |
|------|----------|-------------|-----|
| 1    | DM220CAP | DUST CAP    | 1   |
| KIT  | DM221SS  | REPAIR KIT  | 1   |

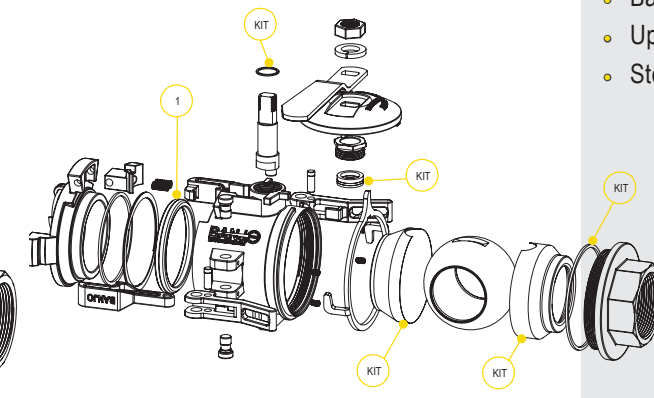

### REPLACEMENT PARTS FEMALE

| ITEM | PART NO  | DESCRIPTION       | QTY |
|------|----------|-------------------|-----|
| 1    | DM25294  | FKM FACE SEAL     | 1   |
| 1    | DM25294T | KALREZ® FACE SEAL | 1   |
| KIT  | DM222SS  | REPAIR KIT        | 1   |

1" POLY DRY FITS

FEATURES

- Double poly-ball valves with integrated quick disconnect
- 1" full-port (unrestricted flow)
- Allows higher pressures & flow
- Economical and simpler design without handle locking feature
- **90+ less spillage** vs. 2 standard valves connected via a coupling



| 1 1/2" POLY MALE DRY FIT™ |                               |         |           |                   |     |
|---------------------------|-------------------------------|---------|-----------|-------------------|-----|
| PART NO                   | DESCRIPTION                   | MAX PSI | PIPE SIZE | OPENING THRU BALL | QTY |
| DF100A                    | 1" MALE X FPT NPT W/FKM SEALS | 100     | 1"        | 1"                | 1   |

| 1 1/2" POLY FEMALE DRY FIT™ |                                 |         |           |                   |     |
|-----------------------------|---------------------------------|---------|-----------|-------------------|-----|
| PART NO                     | DESCRIPTION                     | MAX PSI | PIPE SIZE | OPENING THRU BALL | QTY |
| DF100D                      | 1" FEMALE X FPT NPT W/FKM SEALS | 100     | 1"        | 1"                | 1   |

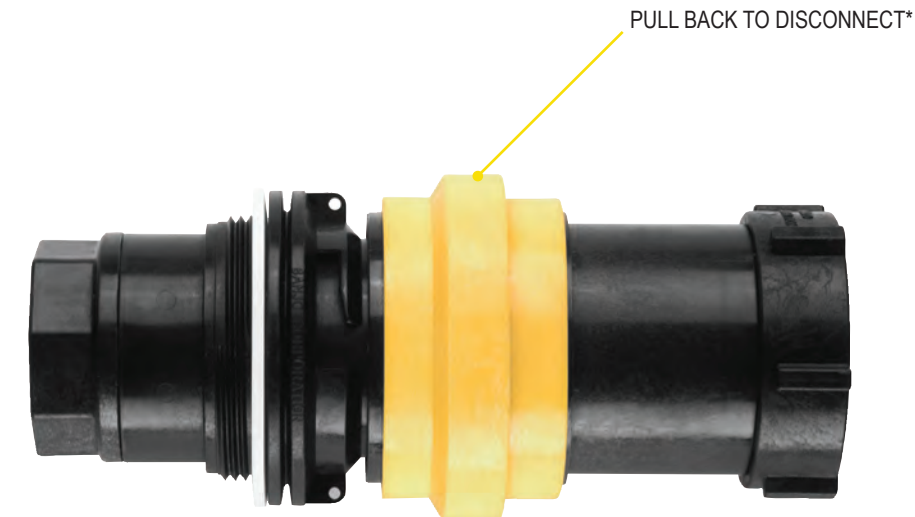

| DRY POPPET COUPLINGS |   |         |     |
|----------------------|---|---------|-----|
| PART NO              | DESCRIPTION   | MAX PSI | QTY |
| DPCF100              | FEMALE DRY POPPET COUPLER, 1" FEMALE NPT THREADS W/ FKM SEALS                       | 100     | 1   |
| DPCM100              | MALE DRY POPPET ADAPTER, 1" FEMALE NPT THREADS W/ FKM SEALS                         | 150     | 1   |
| DPCMT100             | MALE DRY POPPET ADAPTER, W/2" MALE THREADED BODY 1" FEMALE NPT THREADS W/ FKM SEALS | 150     | 1   |

\*Note: Male adapter and female coupler shown coupled together but sold separately.

DRY POPPET COUPLINGS

FEATURES

- Lightweight
- Minimal fluid spillage
- Easy to use
- Economical
- Reduces risk of exposure
- Wide range of chemical resistance
- Maximum operating temperature 150° F
- 30 GPM maximum flow
- Precision molded in polypropylene
- 1" female NPT threads

APPLICATIONS

- Agriculture
- Industrial
- Pharmaceutical
- Chemical processing



SPIN WELD BALL VALVES

FEATURES

- PTFE seats
- FKM stem o-rings
- Precision molded polypropylene is reinforced with fiberglass for additional strength
- Zinc alloy collar
- FKM, EPDM and TPV collar gaskets available
- Handles close in either direction
- For faster shipping, order in box quantities



IDENTIFYING COLLAR NUMBER FOUND HERE

| SPINWELD BALL VALVE |   |                 |             |               |           |         |     |
|---------------------|---|-----------------|-------------|---------------|-----------|---------|-----|
| PART NO             | DESCRIPTION   | GASKET MATERIAL | COLLAR FITS | COLLAR NUMBER | COLLAR ID | MAX PSI | QTY |
| W230237             | 2" POLY SPINWELD VALVE W/NPT OUTLET & CAP & FOIL SEAL | FKM             | MAUSER®     | V22283 C & D  | 2 1/4"    | 20      | 1   |
| W230238             | 2" POLY SPINWELD VALVE W/QDC OUTLET & CAP & FOIL SEAL | FKM             | MAUSER®     | V22283 C & D  | 2 1/4"    | 20      | 1   |
| W230239             | 2" POLY SPINWELD VALVE W/NPT OUTLET & CAP & FOIL SEAL | EPDM            | MAUSER®     | V22283 C & D  | 2 1/4"    | 20      | 1   |
| W230240             | 2" POLY SPINWELD VALVE W/QDC OUTLET & CAP & FOIL SEAL | EPDM            | MAUSER®     | V22283 C & D  | 2 1/4"    | 20      | 1   |
| WSF210FSA           | 2" POLY SPINWELD VALVE W/QDC OUTLET, FOIL SEAL & CAP  | TPV             | SCHUTZ®     | V20280 A & B  | 2 3/4"    | 50      | 1   |
| WSF210FSAV          | 2" POLY SPINWELD VALVE W/QDC OUTLET, FOIL SEAL & CAP  | FKM             | SCHUTZ®     | V20280 A & B  | 2 3/4"    | 50      | 1   |
| WSMT210FSA          | 2" POLY SPINWELD VALVE W/NPT OUTLET, FOIL SEAL & CAP  | TPV             | SCHUTZ®     | V20280 A & B  | 2 3/4"    | 225     | 1   |
| WSMT210FSAV         | 2" POLY SPINWELD VALVE W/NPT OUTLET, FOIL SEAL & CAP  | FKM             | SCHUTZ®     | V20280 A & B  | 2 3/4"    | 225     | 1   |

FDA UNION VALVE AND ADAPTERS

FEATURES

- Precision molded in glass reinforced polypropylene for strength and chemical resistance
- PTFE seats or smooth operation and proper sealing characteristics
- Double EPDM o-rings in stem area for extra sealing protection
- Interlocking body and end plate to allow easy thread connection when installing valves



UNION VALVE AND ADAPTERS

| PART NO   | DESCRIPTION                   | MAX PSI | QTY |
|-----------|-------------------------------|---------|-----|
| MBP200    | 2" BUTTRESS X 2" NPT ASSEMBLY | 200     | 1   |
| NIP2101   | 2" NPT X BSP NIPPLE           | 300     | 1   |
| UV204FPFD | 2" FDA UNION VALVE WITH EPDM  | 225     | 1   |

## TANK LIDS

### FEATURES

- Maximum air flow through vent channels
- Airflow equivalent to a 3" hole
- No secondary venting needed
- Baffled vents
- Center vent goes in underside of lid
- NPT Threads

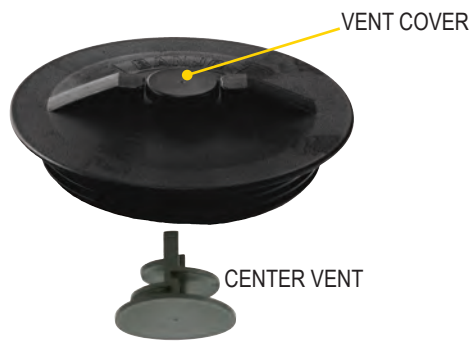

### IBC SOLID TANK LIDS

| PART NO | DESCRIPTION                | GASKET | LOT QTY |
|---------|----------------------------|--------|---------|
| TL650S  | 6" SOLID TANK LID W/GASKET | TPV    | 10      |

### IBC TANK LID WITH UNVENTED PLUG

| PART NO | DESCRIPTION                              | GASKET | LOT QTY |
|---------|--|--------|---------|
| TL651S  | 6" TANK LID W/ UNVENTED 2" PLUG W/GASKET | TPV    | 10      |

### IBC TANK LIDS WITH VENTED PLUG

| PART NO | DESCRIPTION                            | GASKET | QTY |
|---------|--|--------|-----|
| TL652S  | 6" TANK LID W/ VENTED 2" PLUG W/GASKET | TPV    | 1   |
| TL652E  | 6" TANK LID VENTED 2" PLUG W/GASKET    | EPDM   | 1   |

### TANK LID FOR SPRAY TANKS

| PART NO | DESCRIPTION        | GASKET | QTY |
|---------|--------------------|--------|-----|
| TL600C  | 6" VENTED TANK LID | N/A    | 1   |

### VENTED TANK LIDS

| PART NO | DESCRIPTION                                     | GASKET | QTY |
|---------|---|--------|-----|
| TLVA10  | 10" VENTED TANK LID & RING ASSEMBLY (NEW STYLE) | N/A    | 1   |

### SIPHON TUBES

| PART NO | DESCRIPTION         | LOT QTY |
|---------|---------------------|---------|
| ST200   | 2" POLY SIPHON TUBE | 5       |
| ST300   | 3" POLY SIPHON TUBE | 5       |



## POLYPROPYLENE ACCESSORIES

### FEATURES

- Glass reinforced polypropylene



### BUTTRESS BY MALE ADAPTER

| PART NO | DESCRIPTION                                | GASKET | PSI | LOT QTY |
|---------|--|--------|-----|---------|
| TA283   | 2" BUTTRESS X 2" MALE NPT THREADS W/GASKET | TPV    | 300 | 10      |
| TA283QD | 2" BUTTRESS X 2" MALE ADAPTER QDC W GASKET | TPV    | 150 | 10      |



### CAPS

| PART NO | DESCRIPTION                | PSI | QTY |
|---------|----------------------------|-----|-----|
| 201FPT  | 2" FEMALE NPT CAP - BLACK  | 20  | 1   |
| 211FPT  | 2" FEMALE NPT CAP - YELLOW | N/A | 1   |



### BUNG PLUGS

| PART NO | DESCRIPTION                      | QTY |
|---------|----------------------------------|-----|
| 231MPT  | 2" MPT SOLID BUNG W/ EPDM GASKET | 1   |
| TL6531  | 2" VENTED PLUG W/ EPDM GASKET    | 1   |



### DUST CAPS & LANYARD

| PART NO  | DESCRIPTION                                | PSI | LOT QTY |
|----------|--|-----|---------|
| 200CAP   | 2" CAM LEVER DUST CAP                      | 200 | 20      |
| 200CAPSH | 2" CAM LEVER DUST CAP WITH SHORT ARMS      | 200 | 10      |
| 201CAPSH | 2" CAM LEVER DUST CAP W/SHORT ARMS & RINGS | 200 | 10      |
| 202CAP   | 2" CAM LEVER DUST CAP                      | 20  | 10      |
| V20207   | 11" POLYURETHANE LANYARD                   | N/A | 1       |



## BOLTED TANK FLANGES

### FEATURES

- Stainless steel bolts
- Bolt head plugs ultrasonically sealed
- Glass reinforced polypropylene
- EPDM gaskets standard and FKM available
- **WARNING:** Do not tighten tank flange bolts more than 12 ft pounds

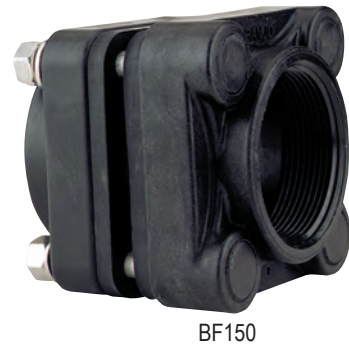

BF150



BF300



### BOLTED TANK FLANGES

| PART NO | DESCRIPTION                              | LOT QTY |
|---------|--|---------|
| BF075   | ¾" X 1" THREADED FLANGE W/EPDM GASKET    | 10      |
| BF100   | 1" X 1" THREADED FLANGE W/EPDM GASKET    | 10      |
| BF150   | 1½" X 2" THREADED FLANGE W/EPDM GASKET   | 5       |
| BF200   | 2" X 2" THREADED FLANGE W/EPDM GASKET    | 10      |
| BF200V  | 2" X 2" THREADED FLANGE W/FKM GASKET     | 10      |
| BF220   | 2" X 2" FP THREADED FLANGE W/EPDM GASKET | 5       |
| BF300   | 3" X 3" THREADED FLANGE W/EPDM GASKET    | 4       |

### BOLTED TANK FLANGE GASKETS

| PART NO | DESCRIPTION              | QTY |
|---------|--------------------------|-----|
| BF100GE | 1" EPDM GASKET           | 1   |
| BF200GE | 1½" & 2" EPDM GASKET     | 1   |
| BF200GV | 1½" & 2" FKM GASKET      | 1   |
| BF220GE | 2" FULL PORT EPDM GASKET | 1   |
| BF220GV | 2" FULL PORT FKM GASKET  | 1   |
| BF300GE | 3" EPDM GASKET           | 1   |
| BF300GV | 3" FKM GASKET            | 1   |

¾" — 2"

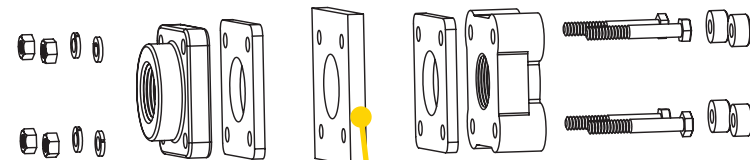

Tank Wall

3"

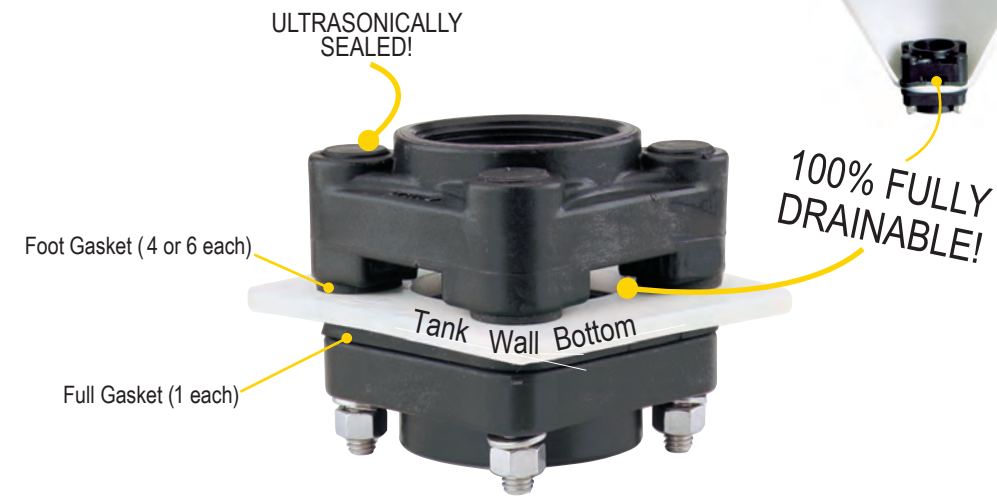
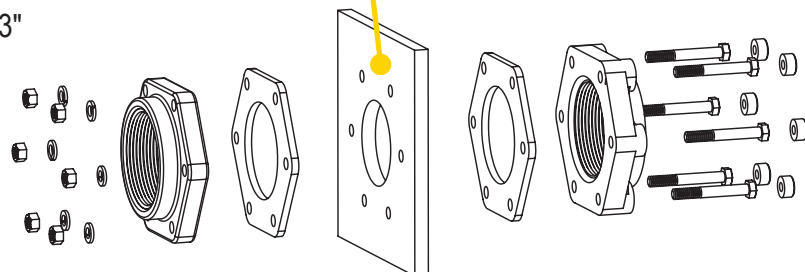

### BOLTED TANK FLANGES

| PART NO | DESCRIPTION  | LOT QTY |
|---------|--|---------|
| BF075BD | ¾" X 1" THREADED POLY FLANGE W/ EPDM GASKET          | 5       |
| BF100BD | 1" X 1" THREADED POLY FLANGE W/EPDM GASKET           | 5       |
| BF150BD | 1½" X 2" THREADED POLY FLANGE W/EPDM GASKET          | 5       |
| BF200BD | 2" X 2" THREADED POLY FLANGE W/EPDM GASKET           | 5       |
| BF220BD | 2" X 2" FULL PORT THREADED POLY FLANGE W/EPDM GASKET | 5       |
| BF300BD | 3" X 3" THREADED POLY FLANGE W/EPDM GASKET           | 4       |

### BOLTED TANK FLANGE GASKETS

| PART NO  | DESCRIPTION                                      | QTY |
|----------|--|-----|
| BF100GE  | ¾", 1" & 1¼" EPDM GASKET                         | 1   |
| BF100GRE | ¾", 1" & 1¼" FOOT EPDM GASKET                    | 1   |
| BF100GRV | ¾", 1" & 1¼" FOOT FKM GASKET                     | 1   |
| BF200GE  | 1½" & 2" EPDM GASKET                             | 1   |
| BF200GV  | 1½" & 2" FKM GASKET                              | 1   |
| BF200GFV | 1½" & 2" STD. PORT, 2" FULL PORT FOOT FKM GASKET | 1   |
| BF220GE  | 2" FULL PORT EPDM GASKET                         | 1   |
| BF220GV  | 2" FULL PORT FKM GASKET                          | 1   |
| BF300GE  | 3" EPDM GASKET                                   | 1   |
| BF300GV  | 3" FKM GASKET                                    | 1   |
| BF300GFE | 3" FOOT EPDM GASKET                              | 1   |
| BF300GFV | 3" FOOT FKM GASKET                               | 1   |

## BOLTED BOTTOM DRAIN TANK FLANGES

### FEATURES

- Stainless steel bolts
- Bolt head plugs ultrasonically sealed
- Glass reinforced polypropylene
- EPDM gaskets standard and FKM available
- Allows 100% rinse free
- No sediment build up
- Excellent for avoiding herbicide cross contamination
- Fits most cone bottom and chemical inductor tanks, 30 gallons and larger.
- For faster shipping, order in box quantities



Tank not included

## BULKHEAD TANK FITTINGS

### FEATURES

- Double sided female NPT threads
- Available with EPDM or FKM gasket
- Parts must be ordered in lot quantities.



### POLY BULKHEAD FITTINGS

| PART NO | DESCRIPTION                                     | HOLE SIZE | MAX PSI | LOT QTY |
|---------|---|-----------|---------|---------|
| TF050   | 1/2" POLY BULKHEAD TANK FITTING W/EPDM GASKET   | 1 5/8"    | 300     | 10/BAG  |
| TF075   | 3/4" POLY BULKHEAD TANK FITTING W/EPDM GASKET   | 1 5/8"    | 300     | 10/BAG  |
| TF075V  | 3/4" POLY BULKHEAD TANK FITTING W/FKM GASKET    | 1 5/8"    | 300     | 10      |
| TF100   | 1" POLY BULKHEAD TANK FITTING W/EPDM GASKET     | 2 1/4"    | 300     | 10/BAG  |
| TF125   | 1 1/4" POLY BULKHEAD TANK FITTING W/EPDM GASKET | 2 1/4"    | 300     | 10      |
| TF150   | 1 1/2" POLY BULKHEAD TANK FITTING W/EPDM GASKET | 3"        | 300     | 10      |
| TF200   | 2" POLY BULKHEAD TANK FITTING W/EPDM GASKET     | 3"        | 300     | 10      |
| TF200V  | 2" POLY BULKHEAD TANK FITTING W/FKM GASKET      | 3"        | 300     | 10      |
| TF220   | 2" POLY BULKHEAD TANK FITTING W/EPDM GASKET     | 3 1/4"    | 300     | 10      |
| TF300   | 3" POLY BULKHEAD TANK FITTING W/EPDM GASKET     | 4 1/2"    | 300     | 5       |
| TF400   | 4" POLY BULKHEAD TANK FITTING W/EPDM GASKET     | 5 3/4"    | 225     | 1       |

### 316 STAINLESS STEEL BULKHEAD FITTINGS

| PART NO | DESCRIPTION                                   | HOLE SIZE | MAX PSI | QTY |
|---------|---|-----------|---------|-----|
| TF038SS | 3/8" SS BULKHEAD TANK FITTING W/EPDM GASKET   | 1"        | 300     | 1   |
| TF050SS | 1/2" SS BULKHEAD TANK FITTING W/EPDM GASKET   | 1 3/8"    | 300     | 1   |
| TF075SS | 3/4" SS BULKHEAD TANK FITTING W/EPDM GASKET   | 1 5/8"    | 300     | 1   |
| TF100SS | 1" SS BULKHEAD TANK FITTING W/EPDM GASKET     | 2 1/4"    | 300     | 1   |
| TF125SS | 1 1/4" SS BULKHEAD TANK FITTING W/EPDM GASKET | 2 1/4"    | 300     | 1   |
| TF150SS | 1 1/2" SS BULKHEAD TANK FITTING W/EPDM GASKET | 3"        | 300     | 1   |
| TF200SS | 2" SS BULKHEAD TANK FITTING W/EPDM GASKET     | 3"        | 300     | 1   |
| TF220SS | 2" SS BULKHEAD TANK FITTING W/EPDM GASKET     | 3 1/4"    | 300     | 1   |
| TF300SS | 3" SS BULKHEAD TANK FITTING W/EPDM GASKET     | 4 3/8"    | 300     | 1   |

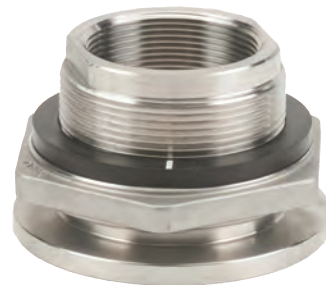

### BULKHEAD GASKETS

| PART NO | DESCRIPTION                      | HOLE SIZE | FITS POLY     | FITS SS           | LOT QTY |
|---------|----------------------------------|-----------|---------------|-------------------|---------|
| 100G    | 3/8" BULKHEAD EPDM GASKET        | 1"        |               | TF038SS           | 25      |
| 100GV   | 3/8" BULKHEAD FKM GASKET         | 1"        |               | TF038SS           | 10      |
| TF100G  | 1" TANK FLANGE EPDM GASKET       | 2 7/32"   |               | TF100V            | 25      |
| TF100GV | 1" TANK FLANGE FKM GASKET        | 2 7/32"   |               | TF100V            | 10      |
| TF138GV | 1/2" BULKHEAD FKM GASKET         | 1 3/8"    |               | TF050SS           | 10      |
| 150G    | 1/2" & 3/4" BULKHEAD EPDM GASKET | 1 5/8"    | TF050 & TF075 | TF075SS           | 25      |
| 150GV   | 1/2" & 3/4" BULKHEAD FKM GASKET  | 1 5/8"    | TF050 & TF075 | TF075SS           | 10      |
| 200G    | 2" BULKHEAD EPDM GASKET          | 2 1/4"    | TF100 & TF125 | TF100SS & TF125SS | 25      |
| 200GV   | 2" BULKHEAD FKM GASKET           | 2 1/4"    | TF100 & TF125 | TF100SS & TF125SS | 10      |
| 300G    | 1 1/2" & 2" BULKHEAD EPDM GASKET | 3"        | TF200 & TF150 | TF200SS & TF150SS | 25      |
| 300GV   | 1 1/2" & 2" BULKHEAD FKM GASKET  | 3"        | TF200 & TF150 | TF200SS & TF150SS | 10      |
| TF220G  | 2" BULKHEAD EPDM GASKET          | 3 1/4"    | TF220         | TF220SS           | 1       |
| TF300G  | 3" BULKHEAD EPDM GASKET          | 4 1/2"    | TF300         | TF300SS           | 1       |
| TF400G  | 4" POLY BULKHEAD EPDM GASKET     | 5 3/4"    | TF400         |                   | 1       |
| TF400GV | 4" POLY BULKHEAD FKM GASKET      | 5 3/4"    | TF400         |                   | 1       |

## ANTI VORTEX VENT CAPS

### FEATURES

- Male NPT
- Glass reinforced polypropylene
- 304 stainless steel screen

PREVENTS SWIRL!



### ANTI VORTEX VENT CAPS

| PART NO | DESCRIPTION                                 | BORE SIZE | BORE AREA | VENT AREA | LOT QTY |
|---------|---|-----------|-----------|-----------|---------|
| VC200   | 2" ANTI VORTEX VENT CAP WITHOUT SCREEN      | 2"        | 3.1 SQ IN | 3.9 SQ IN | 10      |
| VC230   | 2" ANTI VORTEX VENT CAP W/12 MESH SS SCREEN | 2"        | 3.1 SQ IN | 3.9 SQ IN | 10      |
| VC300   | 3" ANTI VORTEX VENT CAP WITHOUT SCREEN      | 3"        | 7 SQ IN   | 9 SQ IN   | 1       |
| VC330   | 3" ANTI VORTEX VENT CAP W/10 MESH SS SCREEN | 3"        | 7 SQ IN   | 9 SQ IN   | 1       |

## ANTI VORTEX TANK FLANGES

### FEATURES

- Standard with FKM
- Prevents swirl in bottom of tank

PREVENTS SWIRL!

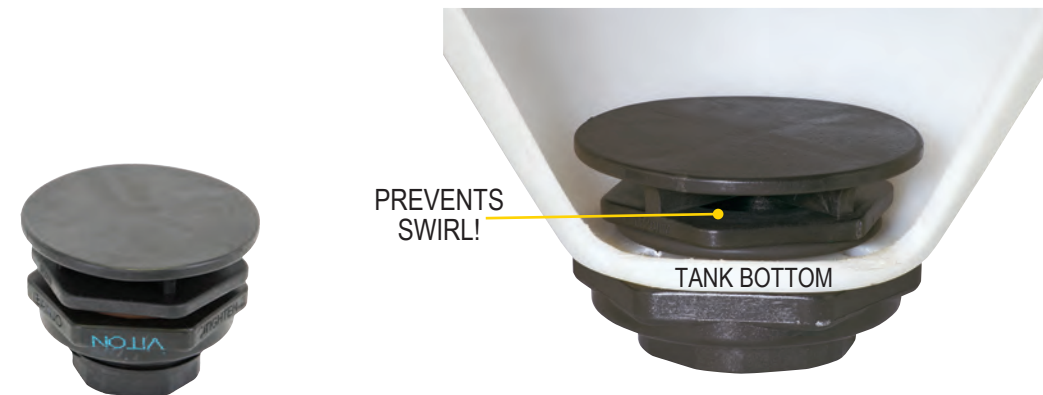

### ANTI VORTEX TANK FLANGES

| PART NO | DESCRIPTION                     | HOLE SIZE | QTY |
|---------|---------------------------------|-----------|-----|
| TF100AV | 1" ANTI VORTEX TANK FLANGES     | 2 1/4"    | 1   |
| TF125AV | 1 1/4" ANTI VORTEX TANK FLANGES | 2 1/4"    | 1   |
| TF150AV | 1 1/2" ANTI VORTEX TANK FLANGES | 3"        | 1   |
| TF200AV | 2" ANTI VORTEX TANK FLANGES     | 3"        | 1   |



## ANSI FLANGES

### FEATURES

- Glass reinforced polypropylene
- Heavy duty



### THREADED ANSI FLANGES

| PART NO | DESCRIPTION                     | LOT QTY |
|---------|---------------------------------|---------|
| AF100   | 1" FEMALE THREADED ANSI FLANGE  | 10/BAG  |
| AF150   | 1½" FEMALE THREADED ANSI FLANGE | 10/BAG  |
| AF200   | 2" FEMALE THREADED ANSI FLANGE  | 10      |
| AF300   | 3" FEMALE THREADED ANSI FLANGE  | 5       |
| AF400   | 4" FEMALE THREADED ANSI FLANGE  | 1       |

### BLIND ANSI FLANGES

| PART NO | DESCRIPTION          | LOT QTY |
|---------|----------------------|---------|
| AFB200  | 2" BLIND ANSI FLANGE | 10/BAG  |
| AFB300  | 3" BLIND ANSI FLANGE | 5       |

### ANSI FLANGE GASKETS

| PART NO | DESCRIPTION                 | QTY |
|---------|-----------------------------|-----|
| AF100G  | 1" ANSI FLANGE EPDM GASKET  | 1   |
| AF100GV | 1" ANSI FLANGE FKM GASKET   | 1   |
| AF150G  | 1½" ANSI FLANGE EPDM GASKET | 1   |
| AF200G  | 2" ANSI FLANGE EPDM GASKET  | 1   |
| AF200GV | 2" ANSI FLANGE FKM GASKET   | 1   |
| AF300G  | 3" ANSI FLANGE EPDM GASKET  | 1   |
| AF300GV | 3" ANSI FLANGE FKM GASKET   | 1   |
| AF400G  | 4" ANSI FLANGE EPDM GASKET  | 1   |
| AF400GV | 4" ANSI FLANGE FKM GASKET   | 1   |

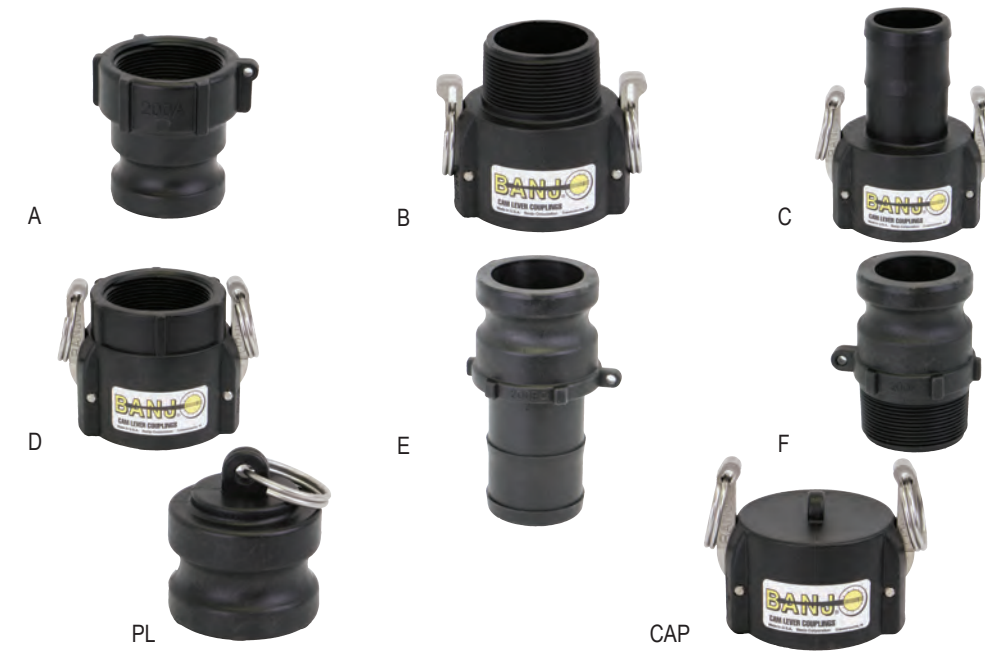

### POLYPROPYLENE CAM LEVER COUPLINGS

| ITEM  | DESCRIPTION                    | ¼"     | ½"     | ¾"     | 1"        | 1¼"       | 1½" x 1¼" | 1½"    | 2"     | 2½"    | 3"     | 3" ARMS | 4" ARMS         |
|-------|--------------------------------|--------|--------|--------|-----------|-----------|-----------|--------|--------|--------|--------|---------|-----------------|
| A     | MALE ADAPTER X FEMALE THREAD   | 75A1/4 | 75A1/2 | 75A3/4 | 100A      | 125A      | 150125A   | 150A   | 200A   |        | 300A   |         | 400A            |
| B     | FEMALE COUPLER X MALE THREAD   |        | 75B1/2 | 75B3/4 | 100B      | 125B      | 150125B   | 150B   | 200B   |        | 300B   | 303B    | 400B            |
| C     | FEMALE COUPLER X HOSE BARB     |        | 050C   | 075C   | 100C      | 125C      | 150125C   | 150C   | 200C   |        | 300C   | 303C    | 400C            |
| D     | FEMALE COUPLER X FEMALE THREAD |        | 050D   | 075D   | 100D      | 125D      | 150125D   | 150D   | 200D   |        | 300D   |         | 400D            |
| E     | MALE ADAPTER X HOSE BARB       |        | 050E   | 075E   | 100E      | 125E      | 150125E   | 150E   | 200E   |        | 300E   |         | 400E            |
| F     | MALE ADAPTER X MALE THREAD     |        | 050F   | 075F   | 100F      | 125F      | 150125F   | 150F   | 200F   |        | 300F   |         | 400F            |
| PL    | PLUG FOR FEMALE COUPLER        |        | 75PL   | 75PL   | 100125PL  | 100125PL  | 150PL     | 150PL  | 200PL  | 250PL  | 300PL  |         | 400PL           |
| CAP   | CAP FOR MALE ADAPTER           |        | 075CAP | 075CAP | 100125CAP | 100125CAP | 150CAP    | 150CAP | 200CAP | 250CAP | 300CAP |         | 400CAP (2 arms) |
| CAPSH | CAP WITH SHORT ARMS            |        |        |        |           |           | 200CAPSH  |        |        |        |        |         |                 |

### ¼" SERIES POLY CAM LEVER COUPLINGS

| PART NO | DESCRIPTION                        | MAX PSI | GASKET | LOT QTY |
|---------|------------------------------------|---------|--------|---------|
| 75A1/4  | ¾" MALE ADAPTER X ¼" FEMALE THREAD | 300     | N/A    | 10/BAG  |

### ½" SERIES POLY CAM LEVER COUPLINGS

| PART NO | DESCRIPTION                          | MAX PSI | GASKET | LOT QTY |
|---------|--------------------------------------|---------|--------|---------|
| 75A1/2  | ¾" MALE ADAPTER X ½" FEMALE THREAD   | 225     | N/A    | 10/BAG  |
| 75B1/2  | ¾" FEMALE COUPLER X ½" MALE THREAD   | 300     | EPDM   | 10/BAG  |
| 050C    | ¾" FEMALE COUPLER X ½" HOSE BARB     | 300     | EPDM   | 10/BAG  |
| 050D    | ¾" FEMALE COUPLER X ½" FEMALE THREAD | 300     | EPDM   | 10/BAG  |
| 050E    | ¾" MALE ADAPTER X ½" HOSE BARB       | 300     | N/A    | 10/BAG  |
| 050F    | ¾" MALE ADAPTER X ½" MALE THREAD     | 300     | N/A    | 10/BAG  |
| 075CAP  | ¾" CAP X MALE ADAPTER                | 300     | EPDM   | 10/BAG  |
| 75PL    | ¾" PLUG X FEMALE COUPLER             | 300     | N/A    | 10/BAG  |

## ¼"-4" POLYPROPYLENE

### FEATURES

- Stainless steel rings, arms and pins
- Versatile — interchangeable with all types of cam lever couplings
- Precision molded — ensures a uniform and accurate fit
- Durable — polypropylene is glass reinforced for rugged strength
- Smooth operating — finger rings are designed for easy opening of cam levers
- Economical and superior in performance
- Parts must be ordered in lot quantities.
- ¼" and ½" series couplings interchange with ¾" size couplings. Coupling ends are ¾" size.
- 1¼" series couplings interchange with 1" size couplings. Coupling ends are 1" size.
- 1½" x 1¼" couplings interchange with 1½" size couplings. Coupling ends are 1½" size.



**WARNING!** Couplings should not be disconnected under pressure or with liquid in the line.

# CAM LEVER COUPLINGS

## 1/4"-4" POLYPROPYLENE

### FEATURES

- Stainless steel rings, arms and pins
- Versatile — interchangeable with all types of cam lever couplings
- Precision molded — ensures a uniform and accurate fit
- Durable — polypropylene is glass reinforced for rugged strength
- Smooth operating — finger rings are designed for easy opening of cam levers
- Economical and superior in performance
- Standard with EPDM gaskets, FKM gaskets can be ordered separately on page 79
- Parts must be ordered in lot quantities.
- 1/4", 3/8" and 1/2" series couplings interchange with 3/4" size couplings. Coupling ends are 3/4" size.
- 1 1/4" series couplings interchange with 1" size couplings. Coupling ends are 1" size.
- 1 1/2" x 1 1/4" couplings interchange with 1 1/2" size couplings. Coupling ends are 1 1/2" size.



WARNING! Couplings should not be disconnected under pressure or with liquid in the line.

| 3/4" SERIES POLY CAM LEVER COUPLINGS |  |         |        |         |
|--------------------------------------|--|---------|--------|---------|
| PART NO                              | DESCRIPTION                              | MAX PSI | GASKET | LOT QTY |
| 75A3/4                               | 3/4" MALE ADAPTER X 3/4" FEMALE THREAD   | 225     | N/A    | 10/BAG  |
| 75B3/4                               | 3/4" FEMALE COUPLER X 3/4" MALE THREAD   | 300     | EPDM   | 10/BAG  |
| 075C                                 | 3/4" FEMALE COUPLER X 3/4" HOSE BARB     | 300     | EPDM   | 10/BAG  |
| 075D                                 | 3/4" FEMALE COUPLER X 3/4" FEMALE THREAD | 300     | EPDM   | 10/BAG  |
| 075E                                 | 3/4" MALE ADAPTER X 3/4" HOSE BARB       | 300     | N/A    | 10/BAG  |
| 075F                                 | 3/4" MALE ADAPTER X 3/4" MALE THREAD     | 300     | N/A    | 10/BAG  |
| 075CAP                               | 3/4" CAP X MALE ADAPTER                  | 300     | EPDM   | 10/BAG  |
| 75PL                                 | 3/4" PLUG X FEMALE COUPLER               | 300     | N/A    | 10/BAG  |

| 1" SERIES POLY CAM LEVER COUPLINGS |                                      |         |        |         |
|------------------------------------|--------------------------------------|---------|--------|---------|
| PART NO                            | DESCRIPTION                          | MAX PSI | GASKET | LOT QTY |
| 100A                               | 1" MALE ADAPTER X 1" FEMALE THREAD   | 300     | N/A    | 10/BAG  |
| 100B                               | 1" FEMALE COUPLER X 1" MALE THREAD   | 300     | EPDM   | 10/BAG  |
| 100C                               | 1" FEMALE COUPLER X 1" HOSE BARB     | 300     | EPDM   | 10/BAG  |
| 100D                               | 1" FEMALE COUPLER X 1" FEMALE THREAD | 300     | EPDM   | 10/BAG  |
| 100E                               | 1" MALE ADAPTER X 1" HOSE BARB       | 300     | N/A    | 10/BAG  |
| 100F                               | 1" MALE ADAPTER X 1" MALE THREAD     | 300     | N/A    | 10/BAG  |
| 100125CAP                          | 1" CAP X MALE ADAPTER                | 300     | EPDM   | 10/BAG  |
| 100125PL                           | 1" PLUG X FEMALE COUPLER             | 300     | N/A    | 10/BAG  |

| 1 1/4" SERIES POLY CAM LEVER COUPLINGS |  |         |        |         |
|--|--|---------|--------|---------|
| PART NO                                | DESCRIPTION                              | MAX PSI | GASKET | LOT QTY |
| 125A                                   | 1" MALE ADAPTER X 1 1/4" FEMALE THREAD   | 300     | N/A    | 10/BAG  |
| 125B                                   | 1" FEMALE COUPLER X 1 1/4" MALE THREAD   | 300     | EPDM   | 10/BAG  |
| 125C                                   | 1" FEMALE COUPLER X 1 1/4" HOSE BARB     | 300     | EPDM   | 10/BAG  |
| 125D                                   | 1" FEMALE COUPLER X 1 1/4" FEMALE THREAD | 300     | EPDM   | 10/BAG  |
| 125E                                   | 1" MALE ADAPTER X 1 1/4" HOSE BARB       | 300     | N/A    | 10/BAG  |
| 125F                                   | 1" MALE ADAPTER X 1 1/4" MALE THREAD     | 300     | N/A    | 10/BAG  |
| 100125CAP                              | 1" CAP X MALE ADAPTER                    | 300     | EPDM   | 10/BAG  |
| 100125PL                               | 1" PLUG X FEMALE COUPLER                 | 300     | N/A    | 10/BAG  |

| 1 1/2" X 1 1/4" SERIES POLY CAM LEVER COUPLINGS |  |         |        |         |
|---|--|---------|--------|---------|
| PART NO   | DESCRIPTION                                  | MAX PSI | GASKET | LOT QTY |
| 150125A   | 1 1/2" MALE ADAPTER X 1 1/4" FEMALE THREAD   | 225     | N/A    | 10/BAG  |
| 150125B   | 1 1/2" FEMALE COUPLER X 1 1/4" MALE THREAD   | 300     | EPDM   | 10      |
| 150125C   | 1 1/2" FEMALE COUPLER X 1 1/4" HOSE BARB     | 300     | EPDM   | 10      |
| 150125D   | 1 1/2" FEMALE COUPLER X 1 1/4" FEMALE THREAD | 300     | EPDM   | 10      |
| 150125E   | 1 1/2" MALE ADAPTER X 1 1/4" HOSE BARB       | 225     | EPDM   | 10/BAG  |
| 150125F   | 1 1/2" MALE ADAPTER X 1 1/4" MALE THREAD     | 300     | N/A    | 10/BAG  |
| 150CAP  | 1 1/2" CAP X MALE ADAPTER                    | 300     | EPDM   | 10      |
| 150PL   | 1 1/2" PLUG X FEMALE COUPLER                 | 225     | N/A    | 10/BAG  |

| 1 1/2" SERIES POLY CAM LEVER COUPLINGS |  |         |        |         |
|--|--|---------|--------|---------|
| PART NO                                | DESCRIPTION                                  | MAX PSI | GASKET | LOT QTY |
| 150A                                   | 1 1/2" MALE ADAPTER X 1 1/2" FEMALE THREAD   | 225     | N/A    | 10/BAG  |
| 150B                                   | 1 1/2" FEMALE COUPLER X 1 1/2" MALE THREAD   | 300     | EPDM   | 10      |
| 150C                                   | 1 1/2" FEMALE COUPLER X 1 1/2" HOSE BARB     | 300     | EPDM   | 10      |
| 150D                                   | 1 1/2" FEMALE COUPLER X 1 1/2" FEMALE THREAD | 300     | EPDM   | 10      |
| 150E                                   | 1 1/2" MALE ADAPTER X 1 1/2" HOSE BARB       | 200     | N/A    | 10/BAG  |
| 150F                                   | 1 1/2" MALE ADAPTER X 1 1/2" MALE THREAD     | 300     | N/A    | 10/BAG  |
| 150CAP                                 | 1 1/2" CAP X MALE ADAPTER                    | 300     | EPDM   | 10      |
| 150PL                                  | 1 1/2" PLUG X FEMALE COUPLER                 | 225     | N/A    | 10/BAG  |



# CAM LEVER COUPLINGS

## 1/4"-4" POLYPROPYLENE

### FEATURES

- Stainless steel rings, arms and pins
- Versatile — interchangeable with all types of cam lever couplings
- Precision molded — ensures a uniform and accurate fit
- Durable — polypropylene is glass reinforced for rugged strength
- Smooth operating — finger rings are designed for easy opening of cam levers
- Economical and superior in performance
- Parts must be ordered in lot quantities.
- 1/4", 3/8" and 1/2" series couplings interchange with 3/4" size couplings. Coupling ends are 3/4" size.
- 1 1/4" series couplings interchange with 1" size couplings. Coupling ends are 1" size.
- 1 1/2" x 1 1/4" couplings interchange with 1 1/2" size couplings. Coupling ends are 1 1/2" size.



WARNING! Couplings should not be disconnected under pressure or with liquid in the line.

| 2" SERIES POLY CAM LEVER COUPLINGS |   |         |        |         |
|------------------------------------|---|---------|--------|---------|
| PART NO                            | DESCRIPTION                                 | MAX PSI | GASKET | LOT QTY |
| 200A                               | 2" MALE ADAPTER X 2" FEMALE THREAD          | 225     | N/A    | 10/BAG  |
| 200B                               | 2" FEMALE COUPLER X 2" MALE THREAD          | 225     | EPDM   | 10/BAG  |
| 201B                               | 2" FEMALE COUPLER X 2" EXTENDED MALE THREAD | 200     | EPDM   | 10/BAG  |
| 200C                               | 2" FEMALE COUPLER X 2" HOSE BARB            | 225     | EPDM   | 10/BAG  |
| 200D                               | 2" FEMALE COUPLER X 2" FEMALE THREAD        | 200     | EPDM   | 10/BAG  |
| 200E                               | 2" MALE ADAPTER X 2" HOSE BARB              | 200     | N/A    | 10/BAG  |
| 200F                               | 2" MALE ADAPTER X 2" MALE THREAD            | 300     | N/A    | 10/BAG  |
| 200CAP                             | 2" CAP X MALE ADAPTER                       | 200     | EPDM   | 10/BAG  |
| 200CAPSH                           | 2" CAP X MALE ADAPTER W/SHORT ARMS          | 200     | EPDM   | 10/BAG  |
| 200PL                              | 2" PLUG X FEMALE COUPLER                    | 225     | N/A    | 10/BAG  |
| M200A                              | 2" FLANGE X 2" MALE ADAPTER                 | 300     | N/A    | 10/BAG  |
| M220A                              | 2" FP FLANGE X 2" MALE ADAPTER              | 225     | N/A    | 10/BAG  |
| M220D                              | 2" FP FLANGE X FEMALE COUPLER               | 225     | EPDM   | 10/BAG  |
| M300A                              | 3" FP FLANGE X 3" MALE ADAPTER              | 100     | N/A    | 1       |
| M303D                              | 3" FP FLANGE X 3" FEMALE COUPLER W/3 ARMS   | 225     | EPDM   | 10/BAG  |

| 2" X 1 1/2" SERIES POLY CAM LEVER COUPLINGS |                                      |         |        |         |
|---|--------------------------------------|---------|--------|---------|
| PART NO                                     | DESCRIPTION                          | MAX PSI | GASKET | LOT QTY |
| 200150C                                     | 2" FEMALE COUPLER X 1 1/2" HOSE BARB | 300     | EPDM   | 10      |

| 2 1/2" SERIES POLY CAM LEVER COUPLINGS |                              |         |        |     |
|--|------------------------------|---------|--------|-----|
| PART NO                                | DESCRIPTION                  | MAX PSI | GASKET | QTY |
| 250CAP                                 | 2 1/2" CAP X MALE ADAPTER    | 300     | EPDM   | 1   |
| 250PL                                  | 2 1/2" PLUG X FEMALE COUPLER | 300     | N/A    | 1   |

| 3" SERIES POLY CAM LEVER COUPLINGS |   |         |        |         |
|------------------------------------|---|---------|--------|---------|
| PART NO                            | DESCRIPTION                                   | MAX PSI | GASKET | LOT QTY |
| 300A                               | 3" MALE ADAPTER X 3" FEMALE THREAD            | 100     | N/A    | 1       |
| 300B                               | 3" FEMALE COUPLER X 3" MALE THREAD            | 150     | EPDM   | 1       |
| 303B                               | 3" FEMALE COUPLER X 3" EXTENDED MALE THREAD   | 200     | EPDM   | 10      |
| 303B200A                           | 3" FEMALE COUPLER W/ 3 ARMS X 2" MALE ADAPTER | 200     | EPDM   | 10      |
| 300C                               | 3" FEMALE COUPLER X 3" HOSE BARB              | 200     | EPDM   | 1       |
| 303C                               | 3" FEMALE COUPLER W/ 3 ARMS X 3" HOSE BARB    | 200     | EPDM   | 10      |
| 300D                               | 3" FEMALE COUPLER X 3" FEMALE THREAD          | 200     | EPDM   | 1       |
| 300E                               | 3" MALE ADAPTER X 3" HOSE BARB                | 150     | N/A    | 1       |
| 300F                               | 3" MALE ADAPTER X 3" MALE THREAD              | 100     | N/A    | 1       |
| 300CAP                             | 3" CAP X MALE ADAPTER                         | 100     | EPDM   | 1       |
| 300PL                              | 3" PLUG X FEMALE COUPLER                      | 150     | N/A    | 1       |

| 4" SERIES POLY CAM LEVER COUPLINGS |                                      |         |        |         |
|------------------------------------|--------------------------------------|---------|--------|---------|
| PART NO                            | DESCRIPTION                          | MAX PSI | GASKET | LOT QTY |
| 400A                               | 4" MALE ADAPTER X 4" FEMALE THREAD   | 75      | N/A    | 1       |
| 400B                               | 4" FEMALE COUPLER X 4" MALE THREAD   | 150     | EPDM   | 1       |
| 400C                               | 4" FEMALE COUPLER X 4" HOSE BARB     | 150     | EPDM   | 1       |
| 400D                               | 4" FEMALE COUPLER X 4" FEMALE THREAD | 100     | EPDM   | 1       |
| 400E                               | 4" MALE ADAPTER X 4" HOSE BARB       | 50      | N/A    | 1       |
| 400F                               | 4" MALE ADAPTER X 4" MALE THREAD     | 75      | N/A    | 1       |
| 400CAP                             | 4" CAP X MALE ADAPTER (W/2 ARMS)     | 100     | EPDM   | 1       |
| 400PL                              | 4" PLUG X FEMALE COUPLER             | 75      | N/A    | 1       |



## 1/4"-4" POLYPROPYLENE

### FEATURES

- Chemical resistant to protect against corrosion
- Versatile to interchange with all types of cam lever couplings
- Smooth operation makes connections quick and easy
- Parts must be ordered in lot quantities.
- Locking cam arm lever is not intended to be used as a security device or prevent unauthorized opening of coupling assembly.

EASY ACTION LOCKING LEVER!



EPDM



FKM

LOCKING ARM WITH RING



PIN

### 1 1/2" - 2" SERIES LOCKING POLY CAM LEVER COUPLINGS

| PART NO | DESCRIPTION                          | MAX PSI | GASKET | QTY |
|---------|--------------------------------------|---------|--------|-----|
| L200B   | 2" FEMALE COUPLER X 2" MALE THREAD   | 225     | EPDM   | 1   |
| L200C   | 2" FEMALE COUPLER X 2" HOSE BARB     | 225     | EPDM   | 1   |
| L200D   | 2" FEMALE COUPLER X 2" FEMALE THREAD | 200     | EPDM   | 1   |
| L200CAP | 2" CAP X MALE ADAPTER                | 200     | EPDM   | 1   |

### SPOOL ADAPTERS

| PART NO  | DESCRIPTION                       | MAX PSI | GASKET | LOT QTY |
|----------|-----------------------------------|---------|--------|---------|
| 200FF    | 2" MALE ADAPTER X 2" MALE ADAPTER | 150     | N/A    | 10/BAG  |
| 300F200F | 3" MALE ADAPTER X 2" MALE ADAPTER | 75      | N/A    | 1       |
| 300FF    | 3" MALE ADAPTER X 3" MALE ADAPTER | 75      | N/A    | 1       |

### REPLACEMENT PARTS

| PART NO   | DESCRIPTION                                   | LOT QTY |
|-----------|---|---------|
| 100RING   | RING FITS 3/4" & 1"                           | 10      |
| 150RING   | RING FITS 1 1/2", 2", 3", 4"                  | 10      |
| 150(200)K | 1 1/2", 2" SS CAM ARM W/RING                  | 1       |
| 300K      | 3" SS CAM ARM WITH RING                       | 1       |
| V20207    | 11" LANYARD                                   | 25      |
| 75G       | 1/2" & 3/4" EPDM GASKET                       | 25      |
| 75GV      | 3/4" FKM GASKET                               | 10      |
| 100G      | 1" & 1 1/4" EPDM GASKET                       | 25      |
| 100GV     | 1" & 1 1/4" FKM GASKET                        | 10      |
| 150G      | 1 1/2" EPDM GASKET                            | 25      |
| 150GV     | 1 1/2" FKM GASKET                             | 10      |
| 200G      | 2" EPDM GASKET                                | 25      |
| 200GV     | 2" FKM GASKET                                 | 10      |
| 300G      | 3" EPDM GASKET                                | 25      |
| 300GV     | 3" FKM GASKET                                 | 10      |
| 400G      | 4" EPDM GASKET                                | 1       |
| 200KL     | 2" LOCKING CAM ARM WITH RING FITS 1 1/2" & 2" | 1       |
| 200PKL    | 2" COUPLING PIN FITS 1 1/2" & 2"              | 1       |
| 200P      | 2" COUPLING PIN                               | 1       |
| 300P      | 3" COUPLING PIN                               | 1       |



A



B



C



D

### 1 1/2" 90° POLY CAM LEVER COUPLINGS

| PART NO | DESCRIPTION                                      | MAX PSI | GASKET | LOT QTY |
|---------|--|---------|--------|---------|
| 150A90  | 1 1/2" 90° MALE ADAPTER X 1 1/2" FEMALE THREAD   | 225     | N/A    | 10/BAG  |
| 150C90  | 1 1/2" 90° FEMALE COUPLER X 1 1/2" HOSE BARB     | 225     | EPDM   | 10      |
| 150D90  | 1 1/2" 90° FEMALE COUPLER X 1 1/2" FEMALE THREAD | 300     | EPDM   | 10      |
| 150F90  | 1 1/2" 90° MALE ADAPTER X 1 1/2" MALE THREAD     | 300     | N/A    | 10/BAG  |

### 2" 90° SERIES POLY CAM LEVER COUPLINGS

| PART NO | DESCRIPTION                              | MAX PSI | GASKET | LOT QTY |
|---------|--|---------|--------|---------|
| 200A90  | 2" 90° MALE ADAPTER X 2" FEMALE THREAD   | 225     | N/A    | 10/BAG  |
| 200B90  | 2" 90° FEMALE COUPLER X 2" MALE THREAD   | 225     | EPDM   | 10      |
| 200C90  | 2" 90° FEMALE COUPLER X 2" HOSE BARB     | 225     | EPDM   | 10      |
| 200D90  | 2" 90° FEMALE COUPLER X 2" FEMALE THREAD | 200     | EPDM   | 10      |
| 200F90  | 2" 90° MALE ADAPTER X 2" MALE THREAD     | 225     | N/A    | 10/BAG  |

### 2" 45° POLY CAM LEVER COUPLINGS

| PART NO | DESCRIPTION                          | MAX PSI | GASKET | LOT QTY |
|---------|--------------------------------------|---------|--------|---------|
| 200F45  | 2" 45° MALE ADAPTER X 2" MALE THREAD | 225     | N/A    | 10/BAG  |

### 2" 45° POLY CAM LEVER COUPLINGS

| PART NO    | DESCRIPTION                       | MAX PSI | GASKET | LOT QTY |
|------------|-----------------------------------|---------|--------|---------|
| M220ASWP90 | 2" FP FLANGE X MALE ADAPTER SWEEP | 200     | N/A    | 10/BAG  |
| M300ASWP90 | 3" FP FLANGE X MALE ADAPTER SWEEP | 100     | N/A    | 1       |



F90



F45

### GARDEN HOSE FITTINGS

| PART NO    | DESCRIPTION                                    | MAX PSI | LOT QTY |
|------------|--|---------|---------|
| GHFT075A   | 3/4" ADAPTER X 3/4" GARDEN HOSE FEMALE THREAD  | 225     | 10/BAG  |
| GHMT075B   | 3/4" COUPLER X 3/4" GARDEN HOSE MALE THREAD    | 300     | 10/BAG  |
| GHFT075D   | 3/4" COUPLER X 3/4" GARDEN HOSE FEMALE THREAD  | 300     | 10/BAG  |
| GHMT075F   | 3/4" ADAPTER X 3/4" GARDEN HOSE MALE THREAD    | 300     | 10/BAG  |
| GHFT075MPT | 3/4" MALE NPT X 3/4" GARDEN HOSE FEMALE THREAD | 300     | 10/BAG  |
| GHMT075FPT | 3/4" FEMALE NPT X 3/4" GARDEN HOSE MALE THREAD | 300     | 10/BAG  |
| GHMT075MPT | 3/4" MALE NPT X 3/4" GARDEN HOSE MALE THREAD   | 300     | 10/BAG  |
| GHFT075G   | 3/4" GARDEN HOSE FITTING GASKET                | N/A     | 25      |

### GARDEN HOSE NOZZLE

| PART NO | DESCRIPTION                   | MAX PSI | QTY |
|---------|-------------------------------|---------|-----|
| GHN075  | 3/4" GARDEN HOSE SPRAY NOZZLE | N/A     | 1   |



Spray nozzle patterns

## 1 1/2"-2" 90° & 45° POLYPROPYLENE

### FEATURES

- Precision molded in polypropylene, reinforced with fiberglass for strength
- Stainless steel rings, arms and pins resist corrosion
- 90° angle couplings and adapters will reduce the number of elbows and other pipe fittings used in plumbing applications



WARNING! Couplings should not be disconnected under pressure or with liquid in the line.

## GARDEN HOSE FITTINGS & NOZZLE

- Same construction and design that farmers use for their heavy spraying applications.
- Rugged, secure quick-connect cam arms
- Heavy-duty thick wall reinforced polypropylene
- Proven, leak-free construction
- Full flow design

### FEATURES

- Heavy duty machined aluminum construction stands up to hard use
- Comfort grip soft rubber
- Resists dents, mars and scratches; protects any surface that comes in contact with nozzle
- Aluminum hose connection provides a tight fit, will not rust
- Multiple spray pattern adjusts from a powerful jet stream to a gentle fan spray. Ideal for all your spraying needs.
- Stainless steel spray cap for precise spray patterns

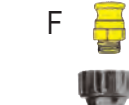
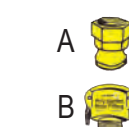

A

B

D

F

## SUPER CLAMPS

### FEATURES

- Stainless steel construction
- 304 stainless steel bolt with 316 stainless steel nut to prevent seizing
- 360° sealing surface
- Ideal for high torque applications
- Strong, positive connections where ordinary hose clamps fail
- T-bolt design
- 3 spot welds for extra strength
- Sold in bags of 10 only
- Torque specifications: working torque 50-80 inch pounds, maximum torque 125 inch pounds
- Please note new Min-Max Diameter measurements.



| SUPER CLAMPS |                          |                  |            |         |
|--------------|--------------------------|------------------|------------|---------|
| PART NO      | DESCRIPTION              | MIN-MAX DIAMETER | MAX TORQUE | LOT QTY |
| TC120        | 1" T-BOLT HOSE CLAMP     | 1.18"-1.34"      | 75 IN-LBS  | 10/BAG  |
| TC130        | 1 1/4" T-BOLT HOSE CLAMP | 1.34"-1.50"      | 75 IN-LBS  | 10/BAG  |
| TC150        | 1 1/2" T-BOLT HOSE CLAMP | 1.50"-1.62"      | 75 IN-LBS  | 10/BAG  |
| TC162        | 1 1/4" T-BOLT HOSE CLAMP | 1.59"-1.87"      | 75 IN-LBS  | 10/BAG  |
| TC181        | 1 1/2" T-BOLT HOSE CLAMP | 1.84"-2.12"      | 75 IN-LBS  | 10/BAG  |
| TC193        | 1 1/2" T-BOLT HOSE CLAMP | 1.90"-2.24"      | 75 IN-LBS  | 10/BAG  |
| TC206        | 2" T-BOLT HOSE CLAMP     | 2.16"-2.40"      | 75 IN-LBS  | 10/BAG  |
| TC218        | 2" T-BOLT HOSE CLAMP     | 2.18"-2.52"      | 75 IN-LBS  | 10/BAG  |
| TC224        | 2" T-BOLT HOSE CLAMP     | 2.24"-2.58"      | 75 IN-LBS  | 10/BAG  |
| TC231        | 2" T-BOLT HOSE CLAMP     | 2.31"-2.65"      | 75 IN-LBS  | 10/BAG  |
| TC250        | 2" T-BOLT HOSE CLAMP     | 2.50"-2.84"      | 75 IN-LBS  | 10/BAG  |
| TC287        | 2" T-BOLT HOSE CLAMP     | 2.87"-3.18"      | 75 IN-LBS  | 10/BAG  |
| TC312        | 3" T-BOLT HOSE CLAMP     | 3.28"-3.50"      | 75 IN-LBS  | 10/BAG  |
| TC331        | 3" T-BOLT HOSE CLAMP     | 3.31"-3.70"      | 75 IN-LBS  | 10/BAG  |
| TC343        | 3" T-BOLT HOSE CLAMP     | 3.50"-3.89"      | 75 IN-LBS  | 10/BAG  |
| TC425        | 4" T-BOLT HOSE CLAMP     | 4.25"-4.64"      | 75 IN-LBS  | 10/BAG  |
| TC438        | 4" T-BOLT HOSE CLAMP     | 4.38"-4.69"      | 180 IN-LBS | 10/BAG  |
| TC456        | 4" T-BOLT HOSE CLAMP     | 4.56"-4.87"      | 180 IN-LBS | 10/BAG  |



| NIPPLES   |                          |         |         |
|-----------|--------------------------|---------|---------|
| PART NO   | DESCRIPTION              | MAX PSI | LOT QTY |
| NIP025-SH | 1/4" SHORT POLY NIPPLE   | 300     | 10/BAG  |
| NIP038-SH | 3/8" SHORT POLY NIPPLE   | 300     | 10/BAG  |
| NIP050-SH | 1/2" SHORT POLY NIPPLE   | 300     | 10/BAG  |
| NIP050-3  | 1/2" X 3" POLY NIPPLE    | 300     | 10/BAG  |
| NIP075-SH | 3/4" SHORT POLY NIPPLE   | 300     | 10/BAG  |
| NIP075-4  | 3/4" X 4" POLY NIPPLE    | 300     | 10/BAG  |
| NIP075-6  | 3/4" X 6" POLY NIPPLE    | 300     | 10/BAG  |
| NIP100-SH | 1" SHORT POLY NIPPLE     | 300     | 10/BAG  |
| NIP100-4  | 1" X 4" POLY NIPPLE      | 300     | 10/BAG  |
| NIP100-6  | 1" X 6" POLY NIPPLE      | 300     | 10/BAG  |
| NIP125-SH | 1 1/4" SHORT POLY NIPPLE | 300     | 10/BAG  |
| NIP125-4  | 1 1/4" X 4" POLY NIPPLE  | 300     | 10/BAG  |
| NIP125-6  | 1 1/4" X 6" POLY NIPPLE  | 300     | 10/BAG  |
| NIP150-SH | 1 1/2" SHORT POLY NIPPLE | 300     | 10/BAG  |
| NIP150-3  | 1 1/2" X 3" POLY NIPPLE  | 300     | 10/BAG  |
| NIP150-4  | 1 1/2" X 4" POLY NIPPLE  | 300     | 10/BAG  |
| NIP150-5  | 1 1/2" X 5" POLY NIPPLE  | 300     | 10/BAG  |
| NIP150-6  | 1 1/2" X 6" POLY NIPPLE  | 300     | 10/BAG  |
| NIP200-SH | 2" SHORT POLY NIPPLE     | 300     | 10/BAG  |
| NIP200-4  | 2" X 4" POLY NIPPLE      | 300     | 10/BAG  |
| NIP200-6  | 2" X 6" POLY NIPPLE      | 300     | 10/BAG  |
| NIP300-SH | 3" SHORT POLY NIPPLE     | 300     | 1       |
| NIP300-4  | 3" X 4" POLY NIPPLE      | 300     | 1       |
| NIP300-6  | 3" X 6" POLY NIPPLE      | 300     | 1       |
| NIP400-SH | 4" SHORT POLY NIPPLE     | 300     | 1       |



| REDUCING NIPPLES |                                      |         |         |
|------------------|--------------------------------------|---------|---------|
| PART NO          | DESCRIPTION                          | MAX PSI | LOT QTY |
| RN050-038        | 1/2" X 3/8" POLY REDUCING NIPPLE     | 300     | 10/BAG  |
| RN075-050        | 3/4" X 1/2" POLY REDUCING NIPPLE     | 300     | 10/BAG  |
| RN100-050        | 1" X 1/2" POLY REDUCING NIPPLE       | 300     | 10/BAG  |
| RN100-075        | 1" X 3/4" POLY REDUCING NIPPLE       | 300     | 10/BAG  |
| RN125-075        | 1 1/4" X 3/4" POLY REDUCING NIPPLE   | 300     | 10/BAG  |
| RN125-100        | 1 1/4" X 1" POLY REDUCING NIPPLE     | 300     | 10/BAG  |
| RN150-100        | 1 1/2" X 1" POLY REDUCING NIPPLE     | 300     | 10/BAG  |
| RN150-125        | 1 1/2" X 1 1/4" POLY REDUCING NIPPLE | 300     | 10/BAG  |
| RN200-125        | 2" X 1 1/4" POLY REDUCING NIPPLE     | 300     | 10/BAG  |
| RN200-150        | 2" X 1 1/2" POLY REDUCING NIPPLE     | 300     | 10/BAG  |
| RN300-200        | 3" X 2" POLY REDUCING NIPPLE         | 300     | 1       |

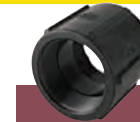

| PIPE COUPLINGS |                           |         |         |
|----------------|---------------------------|---------|---------|
| PART NO        | DESCRIPTION               | MAX PSI | LOT QTY |
| CPLG025        | 1/4" POLY PIPE COUPLING   | 300     | 10/BAG  |
| CPLG038        | 3/8" POLY PIPE COUPLING   | 300     | 10/BAG  |
| CPLG050        | 1/2" POLY PIPE COUPLING   | 300     | 10/BAG  |
| CPLG075        | 3/4" POLY PIPE COUPLING   | 300     | 10/BAG  |
| CPLG100        | 1" POLY PIPE COUPLING     | 300     | 10/BAG  |
| CPLG125        | 1 1/4" POLY PIPE COUPLING | 300     | 10/BAG  |
| CPLG150        | 1 1/2" POLY PIPE COUPLING | 300     | 10/BAG  |
| CPLG200        | 2" POLY PIPE COUPLING     | 300     | 10/BAG  |
| CPLG300        | 3" POLY PIPE COUPLING     | 225     | 5       |



| REDUCING COUPLINGS |  |         |         |
|--------------------|--|---------|---------|
| PART NO            | DESCRIPTION                            | MAX PSI | LOT QTY |
| RC100-075          | 1" X 3/4" POLY REDUCING COUPLING       | 300     | 10/BAG  |
| RC150-100          | 1 1/2" X 1" POLY REDUCING COUPLING     | 300     | 10/BAG  |
| RC150-125          | 1 1/2" X 1 1/4" POLY REDUCING COUPLING | 300     | 10/BAG  |
| RC200-050          | 2" X 1/2" POLY REDUCING COUPLING       | 300     | 10/BAG  |
| RC200-100          | 2" X 1" POLY REDUCING COUPLING         | 300     | 10/BAG  |
| RC200-125          | 2" X 1 1/4" POLY REDUCING COUPLING     | 300     | 10/BAG  |
| RC200-150          | 2" X 1 1/2" POLY REDUCING COUPLING     | 300     | 10/BAG  |
| RC300-200          | 3" X 2" POLY REDUCING COUPLING         | 300     | 5       |

| REDUCING BUSHINGS |  |         |         |
|-------------------|--|---------|---------|
| PART NO           | DESCRIPTION                              | MAX PSI | LOT QTY |
| RB038-025         | 3/8" MPT X 1/4" FPT REDUCING BUSHING     | 300     | 10/BAG  |
| RB050-018         | 1/2" MPT X 1/8" FPT REDUCING BUSHING     | 300     | 10/BAG  |
| RB050-025         | 1/2" MPT X 1/4" FPT REDUCING BUSHING     | 300     | 10/BAG  |
| RB050-038         | 1/2" MPT X 3/8" FPT REDUCING BUSHING     | 300     | 10/BAG  |
| RB075-025         | 3/4" MPT X 1/4" FPT REDUCING BUSHING     | 300     | 10/BAG  |
| RB075-038         | 3/4" MPT X 3/8" FPT REDUCING BUSHING     | 300     | 10/BAG  |
| RB075-050         | 3/4" MPT X 1/2" FPT REDUCING BUSHING     | 300     | 10/BAG  |
| RB100-018         | 1" MPT X 1/8" FPT REDUCING BUSHING       | 300     | 10/BAG  |
| RB100-025         | 1" MPT X 1/4" FPT REDUCING BUSHING       | 300     | 10/BAG  |
| RB100-050         | 1" MPT X 1/2" FPT REDUCING BUSHING       | 300     | 10/BAG  |
| RB100-075         | 1" MPT X 3/4" FPT REDUCING BUSHING       | 300     | 10/BAG  |
| RB125-038         | 1" MPT X 3/8" FPT REDUCING BUSHING       | 300     | 10/BAG  |
| RB125-075         | 1 1/4" MPT X 3/4" FPT REDUCING BUSHING   | 300     | 10/BAG  |
| RB125-100         | 1 1/4" MPT X 1" FPT REDUCING BUSHING     | 300     | 10/BAG  |
| RB150-075         | 1 1/2" MPT X 3/4" FPT REDUCING BUSHING   | 300     | 10/BAG  |
| RB150-100         | 1 1/2" MPT X 1" FPT REDUCING BUSHING     | 300     | 10/BAG  |
| RB150-125         | 1 1/2" MPT X 1 1/4" FPT REDUCING BUSHING | 300     | 10/BAG  |
| RB200-075         | 2" MPT X 3/4" FPT REDUCING BUSHING       | 300     | 10/BAG  |
| RB200-100         | 2" MPT X 1" FPT REDUCING BUSHING         | 300     | 10/BAG  |
| RB200-125         | 2" MPT X 1 1/4" FPT REDUCING BUSHING     | 300     | 10/BAG  |
| RB200-150         | 2" MPT X 1 1/2" FPT REDUCING BUSHING     | 300     | 10/BAG  |
| RB300-150         | 3" MPT X 1 1/2" FPT REDUCING BUSHING     | 300     | 1       |
| RB300-200         | 3" MPT X 2" FPT REDUCING BUSHING         | 300     | 1       |
| RB400-300         | 4" MPT X 3" FPT REDUCING BUSHING         | 300     | 5       |



## PIPE FITTINGS

### FEATURES

- Glass reinforced polypropylene
- Heavy duty (Schedule 80)
- Lightweight with excellent strength
- NPT threads
- Excellent chemical resistance
- Parts must be ordered in lot quantities.



## PIPE FITTINGS

### FEATURES

- Glass reinforced polypropylene
- Heavy duty (Schedule 80)
- Lightweight with excellent strength
- NPT threads
- Excellent chemical resistance
- Parts must be ordered in lot quantities.



### PIPE CAPS

| PART NO | DESCRIPTION          | MAX PSI | LOT QTY |
|---------|----------------------|---------|---------|
| CAP038  | 3/8" POLY PIPE CAP   | 300     | 10/BAG  |
| CAP050  | 1/2" POLY PIPE CAP   | 300     | 10/BAG  |
| CAP075  | 3/4" POLY PIPE CAP   | 300     | 10/BAG  |
| CAP100  | 1" POLY PIPE CAP     | 300     | 10/BAG  |
| CAP125  | 1 1/4" POLY PIPE CAP | 300     | 10/BAG  |
| CAP150  | 1 1/2" POLY PIPE CAP | 300     | 10/BAG  |
| CAP200  | 2" POLY PIPE CAP     | 300     | 10/BAG  |
| CAP300  | 3" POLY PIPE CAP     | 300     | 5       |

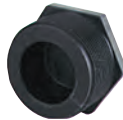

### PIPE PLUGS

| PART NO | DESCRIPTION           | MAX PSI | LOT QTY |
|---------|-----------------------|---------|---------|
| PLUG025 | 1/4" POLY PIPE PLUG   | 300     | 10/BAG  |
| PLUG038 | 3/8" POLY PIPE PLUG   | 300     | 10/BAG  |
| PLUG050 | 1/2" POLY PIPE PLUG   | 300     | 10/BAG  |
| PLUG075 | 3/4" POLY PIPE PLUG   | 300     | 10/BAG  |
| PLUG100 | 1" POLY PIPE PLUG     | 300     | 10/BAG  |
| PLUG125 | 1 1/4" POLY PIPE PLUG | 300     | 10/BAG  |
| PLUG150 | 1 1/2" POLY PIPE PLUG | 300     | 10/BAG  |
| PLUG200 | 2" POLY PIPE PLUG     | 300     | 10/BAG  |
| PLUG300 | 3" POLY PIPE PLUG     | 300     | 1       |



### HOSE BARB CROSS

| PART NO   | DESCRIPTION                 | MAX PSI | LOT QTY |
|-----------|-----------------------------|---------|---------|
| HBC050075 | 1/2" X 3/4" HOSE BARB CROSS | 300     | 10/BAG  |



### CROSSES

| PART NO | DESCRIPTION       | MAX PSI | LOT QTY |
|---------|-------------------|---------|---------|
| CR025   | 1/4" POLY CROSS   | 300     | 10/BAG  |
| CR038   | 3/8" POLY CROSS   | 300     | 10/BAG  |
| CR050   | 1/2" POLY CROSS   | 300     | 10/BAG  |
| CR075   | 3/4" POLY CROSS   | 300     | 10/BAG  |
| CR100   | 1" POLY CROSS     | 300     | 10/BAG  |
| CR125   | 1 1/4" POLY CROSS | 300     | 10/BAG  |
| CR150   | 1 1/2" POLY CROSS | 300     | 10      |
| CR200   | 2" POLY CROSS     | 300     | 10      |



### TEES

| PART NO | DESCRIPTION     | MAX PSI | LOT QTY |
|---------|-----------------|---------|---------|
| TEE025  | 1/4" POLY TEE   | 300     | 10/BAG  |
| TEE038  | 3/8" POLY TEE   | 300     | 10/BAG  |
| TEE050  | 1/2" POLY TEE   | 300     | 10/BAG  |
| TEE075  | 3/4" POLY TEE   | 300     | 10/BAG  |
| TEE100  | 1" POLY TEE     | 300     | 10/BAG  |
| TEE125  | 1 1/4" POLY TEE | 300     | 10/BAG  |
| TEE150  | 1 1/2" POLY TEE | 300     | 10/BAG  |
| TEE200  | 2" POLY TEE     | 300     | 10      |
| TEE300  | 3" POLY TEE     | 225     | 1       |



### GAUGE PORT TEE

| PART NO | DESCRIPTION                         | MAX PSI | LOT QTY |
|---------|-------------------------------------|---------|---------|
| TEG075  | 3/4" POLY TEE W/ 1/4" FEMALE THREAD | 300     | 10/BAG  |
| TEG100  | 1" POLY TEE W/ 1/4" FEMALE THREAD   | 300     | 10/BAG  |



### 90° ELBOWS

| PART NO  | DESCRIPTION           | MAX PSI | LOT QTY |
|----------|-----------------------|---------|---------|
| EL025-90 | 1/4" 90° POLY ELBOW   | 300     | 10/BAG  |
| EL038-90 | 3/8" 90° POLY ELBOW   | 300     | 10/BAG  |
| EL050-90 | 1/2" 90° POLY ELBOW   | 300     | 10/BAG  |
| EL075-90 | 3/4" 90° POLY ELBOW   | 300     | 10/BAG  |
| EL100-90 | 1" 90° POLY ELBOW     | 300     | 10/BAG  |
| EL125-90 | 1 1/4" 90° POLY ELBOW | 300     | 10/BAG  |
| EL150-90 | 1 1/2" 90° POLY ELBOW | 300     | 10/BAG  |
| EL200-90 | 2" 90° POLY ELBOW     | 300     | 10/BAG  |
| EL300-90 | 3" 90° POLY ELBOW     | 300     | 1       |



### 45° ELBOW

| PART NO  | DESCRIPTION       | MAX PSI | LOT QTY |
|----------|-------------------|---------|---------|
| EL100-45 | 1" 45° POLY ELBOW | 300     | 10/BAG  |



### 90° STREET ELBOWS

| PART NO  | DESCRIPTION                  | MAX PSI | LOT QTY |
|----------|------------------------------|---------|---------|
| SL025-90 | 1/4" 90° POLY STREET ELBOW   | 300     | 10/BAG  |
| SL038-90 | 3/8" 90° POLY STREET ELBOW   | 300     | 10/BAG  |
| SL050-90 | 1/2" 90° POLY STREET ELBOW   | 300     | 10/BAG  |
| SL075-90 | 3/4" 90° POLY STREET ELBOW   | 300     | 10/BAG  |
| SL100-90 | 1" 90° POLY STREET ELBOW     | 300     | 10/BAG  |
| SL125-90 | 1 1/4" 90° POLY STREET ELBOW | 300     | 10/BAG  |
| SL150-90 | 1 1/2" 90° POLY STREET ELBOW | 300     | 10/BAG  |
| SL200-90 | 2" 90° POLY STREET ELBOW     | 300     | 10/BAG  |
| SL300-90 | 3" 90° POLY STREET ELBOW     | 300     | 1       |



### 45° STREET ELBOWS

| PART NO  | DESCRIPTION                  | MAX PSI | LOT QTY |
|----------|------------------------------|---------|---------|
| SL075-45 | 3/4" 45° POLY STREET ELBOW   | 300     | 10/BAG  |
| SL100-45 | 1" 45° POLY STREET ELBOW     | 300     | 10/BAG  |
| SL125-45 | 1 1/4" 45° POLY STREET ELBOW | 300     | 10/BAG  |
| SL150-45 | 1 1/2" 45° POLY STREET ELBOW | 300     | 10/BAG  |
| SL200-45 | 2" 45° POLY STREET ELBOW     | 225     | 10/BAG  |
| SL300-45 | 3" 45° POLY STREET ELBOW     | 300     | 5       |



### 90° HOSE BARB ELBOW

| PART NO     | DESCRIPTION                          | MAX PSI | LOT QTY |
|-------------|--------------------------------------|---------|---------|
| HBB20012590 | 2" X 1 1/4" 90° POLY HOSE BARB ELBOW | 300     | 10/BAG  |



### 90° HOSE BARB ELBOW

| PART NO        | DESCRIPTION                          | MAX PSI | LOT QTY |
|----------------|--------------------------------------|---------|---------|
| HBEL100-90     | 1" 90° POLY HOSE BARB ELBOW          | 300     | 10/BAG  |
| HBEL150/100-90 | 1 1/2" X 1" 90° POLY HOSE BARB ELBOW | 300     | 10/BAG  |

## PIPE FITTINGS

### FEATURES

- Glass reinforced polypropylene
- Heavy duty (Schedule 80)
- Lightweight with excellent strength
- NPT threads
- Excellent chemical resistance
- Parts must be ordered in lot quantities.

## HOSE BARBS



### FEATURES

- Glass reinforced polypropylene
- Heavy duty (Schedule 80)
- Lightweight with excellent strength
- NPT threads
- Excellent chemical resistance
- Parts must be ordered in lot quantities.

| STRAIGHT HOSE BARBS |                                       |         |         |
|---------------------|---------------------------------------|---------|---------|
| PART NO             | DESCRIPTION                           | MAX PSI | LOT QTY |
| HB025               | 1/4" MALE THREAD X 1/4" HOSE BARB     | 300     | 10/BAG  |
| HB025-038           | 1/4" MALE THREAD X 3/8" HOSE BARB     | 300     | 10/BAG  |
| HB025-050           | 1/4" MALE THREAD X 1/2" HOSE BARB     | 300     | 10/BAG  |
| HB038               | 3/8" MALE THREAD X 3/8" HOSE BARB     | 300     | 10/BAG  |
| HB038-025           | 3/8" MALE THREAD X 1/4" HOSE BARB     | 300     | 10/BAG  |
| HB038-050           | 3/8" MALE THREAD X 1/2" HOSE BARB     | 300     | 10/BAG  |
| HB050-025           | 1/2" MALE THREAD X 1/4" HOSE BARB     | 300     | 10/BAG  |
| HB050-038           | 1/2" MALE THREAD X 3/8" HOSE BARB     | 300     | 10/BAG  |
| HB050               | 1/2" MALE THREAD X 1/2" HOSE BARB     | 300     | 10/BAG  |
| HB050-075           | 1/2" MALE THREAD X 3/4" HOSE BARB     | 300     | 10/BAG  |
| HB075-038           | 3/4" MALE THREAD X 3/8" HOSE BARB     | 300     | 10/BAG  |
| HB075-050           | 3/4" MALE THREAD X 1/2" HOSE BARB     | 300     | 10/BAG  |
| HB075-058           | 3/4" MALE THREAD X 5/8" HOSE BARB     | 300     | 10/BAG  |
| HB075               | 3/4" MALE THREAD X 3/4" HOSE BARB     | 300     | 10/BAG  |
| HB075-100           | 3/4" MALE THREAD X 1" HOSE BARB       | 300     | 10/BAG  |
| HB100-075           | 1" MALE THREAD X 3/4" HOSE BARB       | 300     | 10/BAG  |
| HB100               | 1" MALE THREAD X 1" HOSE BARB         | 300     | 10/BAG  |
| HB100-125           | 1" MALE THREAD X 1 1/4" HOSE BARB     | 300     | 10/BAG  |
| HB125-075           | 1 1/4" MALE THREAD X 3/4" HOSE BARB   | 300     | 10/BAG  |
| HB125-100           | 1 1/4" MALE THREAD X 1" HOSE BARB     | 300     | 10/BAG  |
| HB125               | 1 1/4" MALE THREAD X 1 1/4" HOSE BARB | 300     | 10/BAG  |
| HB125-150           | 1 1/4" MALE THREAD X 1 1/2" HOSE BARB | 300     | 10/BAG  |
| HB150-100           | 1 1/2" MALE THREAD X 1" HOSE BARB     | 300     | 10/BAG  |
| HB150-125           | 1 1/2" MALE THREAD X 1 1/4" HOSE BARB | 300     | 10/BAG  |
| HB150               | 1 1/2" MALE THREAD X 1 1/2" HOSE BARB | 300     | 10/BAG  |
| HB150-200           | 1 1/2" MALE THREAD X 2" HOSE BARB     | 300     | 10/BAG  |
| HB200-150           | 2" MALE THREAD X 1 1/2" HOSE BARB     | 300     | 10/BAG  |
| HB200               | 2" MALE THREAD X 2" HOSE BARB         | 300     | 10/BAG  |
| HB300               | 3" MALE THREAD X 3" HOSE BARB         | 225     | 1       |
| HB400               | 4" MALE THREAD X 4" HOSE BARB         | 150     | 1       |



| FEMALE HOSE BARBS |   |         |         |
|-------------------|---|---------|---------|
| PART NO           | DESCRIPTION                             | MAX PSI | LOT QTY |
| HB075             | 3/4" FEMALE THREAD X 3/4" HOSE BARB     | 300     | 10/BAG  |
| HB075-90          | 3/4" FEMALE THREAD X 3/4" 90° HOSE BARB | 300     | 10/BAG  |
| HB075-100         | 3/4" FEMALE THREAD X 1" HOSE BARB       | 300     | 10/BAG  |
| HB075-100         | 3/4" FEMALE THREAD X 1" HOSE BARB       | 300     | 10/BAG  |
| HB075-100-90      | 3/4" FEMALE THREAD X 1" 90° HOSE BARB   | 300     | 10/BAG  |



| 90° HOSE BARBS |   |         |         |
|----------------|---|---------|---------|
| PART NO        | DESCRIPTION                               | MAX PSI | LOT QTY |
| HB025-90       | 1/4" MALE THREAD X 1/4" 90° HOSE BARB     | 300     | 10/BAG  |
| HB025/038-90   | 1/4" MALE THREAD X 3/8" 90° HOSE BARB     | 300     | 10/BAG  |
| HB025/050-90   | 1/4" MALE THREAD X 1/2" 90° HOSE BARB     | 300     | 10/BAG  |
| HB038-90       | 3/8" MALE THREAD X 3/8" 90° HOSE BARB     | 300     | 10/BAG  |
| HB050/038-90   | 1/2" MALE THREAD X 3/8" 90° HOSE BARB     | 300     | 10/BAG  |
| HB050-90       | 1/2" MALE THREAD X 1/2" 90° HOSE BARB     | 300     | 10/BAG  |
| HB050/075-90   | 1/2" MALE THREAD X 3/4" 90° HOSE BARB     | 300     | 10/BAG  |
| HB075/050-90   | 3/4" MALE THREAD X 1/2" 90° HOSE BARB     | 300     | 10/BAG  |
| HB075-90       | 3/4" MALE THREAD X 3/4" 90° HOSE BARB     | 300     | 10/BAG  |
| HB075/100-90   | 3/4" MALE THREAD X 1" 90° HOSE BARB       | 300     | 10/BAG  |
| HB100/075-90   | 1" MALE THREAD X 3/4" 90° HOSE BARB       | 300     | 10/BAG  |
| HB100-90       | 1" MALE THREAD X 1" 90° HOSE BARB         | 300     | 10/BAG  |
| HB100/125-90   | 1" MALE THREAD X 1 1/4" 90° HOSE BARB     | 300     | 10/BAG  |
| HB125/100-90   | 1 1/4" MALE THREAD X 1" 90° HOSE BARB     | 300     | 10/BAG  |
| HB125-90       | 1 1/4" MALE THREAD X 1 1/4" 90° HOSE BARB | 300     | 10/BAG  |
| HB125/150-90   | 1 1/4" MALE THREAD X 1 1/2" 90° HOSE BARB | 300     | 10/BAG  |
| HB150-90       | 1 1/2" MALE THREAD X 1 1/2" 90° HOSE BARB | 300     | 10/BAG  |
| HB200/150-90   | 2" MALE THREAD X 1 1/2" 90° HOSE BARB     | 300     | 10/BAG  |
| HB200-90       | 2" MALE THREAD X 2" 90° HOSE BARB         | 300     | 10/BAG  |
| HB300-90       | 3" MALE THREAD X 3" 90° HOSE BARB         | 225     | 1       |



| 316 STAINLESS STEEL HOSE BARBS |                                       |         |         |
|--------------------------------|---------------------------------------|---------|---------|
| PART NO                        | DESCRIPTION                           | MAX PSI | LOT QTY |
| HB025SS                        | 1/4" MALE THREAD X 1/4" HOSE BARB     | 300     | 10      |
| HB025-038SS                    | 1/4" MALE THREAD X 3/8" HOSE BARB     | 300     | 10      |
| HB025-050SS                    | 1/4" MALE THREAD X 1/2" HOSE BARB     | 300     | 10      |
| HB038SS                        | 3/8" MALE THREAD X 3/8" HOSE BARB     | 300     | 10      |
| HB038-050SS                    | 3/8" MALE THREAD X 1/2" HOSE BARB     | 300     | 10      |
| HB050SS                        | 1/2" MALE THREAD X 1/2" HOSE BARB     | 300     | 10      |
| HB050-058SS                    | 1/2" MALE THREAD X 5/8" HOSE BARB     | 300     | 1       |
| HB050-075SS                    | 1/2" MALE THREAD X 3/4" HOSE BARB     | 300     | 10      |
| HB075-050SS                    | 3/4" MALE THREAD X 1/2" HOSE BARB     | 300     | 10      |
| HB075SS                        | 3/4" MALE THREAD X 3/4" HOSE BARB     | 300     | 10      |
| HB075-100SS                    | 3/4" MALE THREAD X 1" HOSE BARB       | 300     | 1       |
| HB100-075SS                    | 1" MALE THREAD X 3/4" HOSE BARB       | 300     | 1       |
| HB100SS                        | 1" MALE THREAD X 1" HOSE BARB         | 300     | 10      |
| HB125SS                        | 1 1/4" MALE THREAD X 1 1/4" HOSE BARB | 300     | 1       |
| HB150SS                        | 1 1/2" MALE THREAD X 1 1/2" HOSE BARB | 300     | 10      |
| HB200SS                        | 2" MALE THREAD X 2" HOSE BARB         | 300     | 1       |
| HB300SS                        | 3" MALE THREAD X 3" HOSE BARB         | 300     | 1       |



| HOSE BARB TEES |                                  |         |         |
|----------------|----------------------------------|---------|---------|
| PART NO        | DESCRIPTION                      | MAX PSI | LOT QTY |
| HBT025         | 1/4" HOSE BARB TEE               | 300     | 10/BAG  |
| HBT038         | 3/8" HOSE BARB TEE               | 300     | 10/BAG  |
| HBT050         | 1/2" HOSE BARB TEE               | 300     | 10/BAG  |
| HBT050-038     | 1/2" X 3/8" HOSE BARB TEE        | 300     | 10/BAG  |
| HBT050-075     | 1/2" X 1/2" X 3/4" HOSE BARB TEE | 300     | 10/BAG  |
| HBT075-050     | 3/4" X 3/4" X 1/2" HOSE BARB TEE | 300     | 10/BAG  |
| HBT075         | 3/4" HOSE BARB TEE               | 300     | 10/BAG  |
| HBT075-100     | 3/4" X 3/4" X 1" HOSE BARB TEE   | 300     | 10/BAG  |
| HBT100-075     | 1" X 1" X 3/4" HOSE BARB TEE     | 300     | 10/BAG  |
| HBT100         | 1" HOSE BARB TEE                 | 300     | 10/BAG  |
| HBT200         | 2" HOSE BARB TEE                 | 300     | 10      |
| HBT300         | 3" HOSE BARB TEE                 | 300     | 1       |



| HOSE BARB THREADED TEES |  |         |         |
|-------------------------|--|---------|---------|
| PART NO                 | DESCRIPTION  | MAX PSI | LOT QTY |
| HBT100-100              | 1" HOSE BARB X 1" HOSE BARB X 1" MALE THREAD HOSE BARB TEE             | 300     | 10/BAG  |
| HBT150-100              | 1 1/2" HOSE BARB X 1 1/2" HOSE BARB X 1" MALE THREAD HOSE BARB TEE     | 300     | 10/BAG  |
| HBT150-150              | 1 1/2" HOSE BARB X 1 1/2" HOSE BARB X 1 1/2" MALE THREAD HOSE BARB TEE | 300     | 10/BAG  |



| SS HOSE BARB THREADED TEES |  |         |     |
|----------------------------|--|---------|-----|
| PART NO                    | DESCRIPTION  | MAX PSI | QTY |
| HBT075-050SS               | 3/4" HOSE BARB X 3/4" HOSE BARB X 1/2" HOSE BARB TEE | N/A     | 1   |



| HOSE MENDERS |                           |         |         |
|--------------|---------------------------|---------|---------|
| PART NO      | DESCRIPTION               | MAX PSI | LOT QTY |
| HM038        | 3/8" X 3/8" HOSE BARB     | 300     | 10/BAG  |
| HM050        | 1/2" X 1/2" HOSE BARB     | 300     | 10/BAG  |
| HM075        | 3/4" X 3/4" HOSE BARB     | 300     | 10/BAG  |
| HM100        | 1" X 1" HOSE BARB         | 300     | 10/BAG  |
| HM125        | 1 1/4" X 1 1/4" HOSE BARB | 300     | 10/BAG  |
| HM150        | 1 1/2" X 1 1/2" HOSE BARB | 300     | 10/BAG  |
| HM200        | 2" X 2" HOSE BARB         | 300     | 10/BAG  |
| HM300        | 3" X 3" HOSE BARB         | 300     | 10      |



| SWIVELS |  |         |         |
|---------|--|---------|---------|
| PART NO | DESCRIPTION                                    | MAX PSI | LOT QTY |
| SW100   | 1" MALE X 1" FEMALE SWIVEL                     | 300     | 10      |
| SW150   | 1 1/2" MALE X 1 1/2" FEMALE SWIVEL             | 300     | 1       |
| SW220   | 2" FULL PORT MALE X 2" FULL PORT FEMALE SWIVEL | 150     | 1       |



| 8 STATION MANIFOLD |   |         |     |
|--------------------|---|---------|-----|
| PART NO            | DESCRIPTION   | MAX PSI | QTY |
| TM075/050          | 8 STATION MANIFOLD 3/4" INLET X 1/2" OUTLET 1/4" GAUGE PORT | 225     | 1   |

## PIPE FITTINGS

### FEATURES

- Glass reinforced polypropylene
- Heavy duty (Schedule 80)
- Lightweight with excellent strength
- NPT threads
- Excellent chemical resistance
- Parts must be ordered in lot quantities.

## PIPE SEALANT

### FEATURES

- RectorSeal® No. 21™ is slow drying, soft set multi-purpose sealant designed for use where black is preferred. 8 oz can with brush in the cap. Conforms to TT-S-1732.
- RectorSeal® Tru-Blu™ is fast drying, flexible set designed for high vibration environments. Teflon™ has been added to enhance thread lubrication during assembly and break out. Conforms to TT-S-1732. \*DuPont Registered Trademark

Recommended procedure for sealing pipe threads:

We DO NOT recommend using pipe tape. Pipe tape enlarges the outside diameter of the male thread and may cause the female thread to split. We recommend using a pipe thread sealant. Use on clean tapered threads. Apply a thick even coat on male threads using brush applicator. For pipe diameters smaller than 1 1/4" apply to male threads only. For 1 1/4" and larger sizes apply to both male and female threads. Avoid applying excessive amounts. Hand tighten joints and then torque another 1/2 to 3/4 turn until threads seal.



| PIPE SEALANT |   |         |
|--------------|---|---------|
| PART NO      | DESCRIPTION   | LOT QTY |
| RS21         | RECTORSEAL® NO. 21™ (8 OZ W/ BRUSH IN CAP-24/CASE)  | 1       |
| RSTB         | RECTORSEAL® TRU-BLU™ (8 OZ W/ BRUSH IN CAP-24/CASE) | 24      |



## MINI T STRAINERS

### FEATURES

- Heavy duty glass reinforced polypropylene
- Clear bowl made of polycarbonate
- Black bowl made of polypropylene
- Polypropylene ribbed 316 stainless steel screens
- EPDM gaskets
- Convenient color coded screens for easy mesh size identification (Refer to chart on next page)



### MINI T STRAINERS W/CLEAR BOWLS

| PART NO     | DESCRIPTION                                      | MAX PSI | QTY |
|-------------|--|---------|-----|
| LSTM050-30C | 1/2" X 1/2" CLEAR BOWL STRAINER W/30 MESH SCREEN | 100     | 1   |
| LSTM050-50C | 1/2" X 1/2" CLEAR BOWL STRAINER W/50 MESH SCREEN | 100     | 1   |
| LSTM050-80C | 1/2" X 1/2" CLEAR BOWL STRAINER W/80 MESH SCREEN | 100     | 1   |
| LSTM075-30C | 3/4" X 3/4" CLEAR BOWL STRAINER W/30 MESH SCREEN | 100     | 1   |
| LSTM075-50C | 3/4" X 3/4" CLEAR BOWL STRAINER W/50 MESH SCREEN | 100     | 1   |
| LSTM075-80C | 3/4" X 3/4" CLEAR BOWL STRAINER W/80 MESH SCREEN | 100     | 1   |



### MINI T STRAINERS W/BLACK BOWLS

| PART NO    | DESCRIPTION                                      | MAX PSI | QTY |
|------------|--|---------|-----|
| LSTM050-30 | 1/2" X 1/2" BLACK BOWL STRAINER W/30 MESH SCREEN | 200     | 1   |
| LSTM050-50 | 1/2" X 1/2" BLACK BOWL STRAINER W/50 MESH SCREEN | 200     | 1   |
| LSTM050-80 | 1/2" X 1/2" BLACK BOWL STRAINER W/80 MESH SCREEN | 200     | 1   |
| LSTM075-30 | 3/4" X 3/4" BLACK BOWL STRAINER W/30 MESH SCREEN | 200     | 1   |
| LSTM075-50 | 3/4" X 3/4" BLACK BOWL STRAINER W/50 MESH SCREEN | 200     | 1   |
| LSTM075-80 | 3/4" X 3/4" BLACK BOWL STRAINER W/80 MESH SCREEN | 200     | 1   |

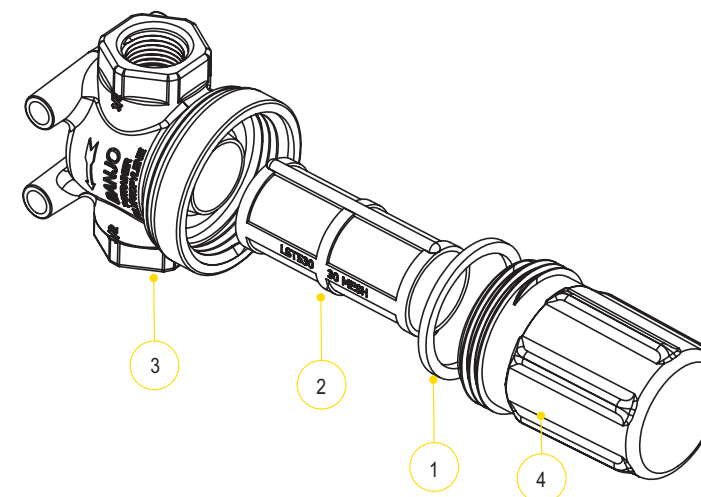

### REPLACEMENT PARTS

| ITEM | PART NO   | DESCRIPTION        | QTY |
|------|-----------|--------------------|-----|
| 1    | LSTM050G  | EPDM GASKET        | 1   |
| 2    | LST530    | 30 MESH SCREEN     | 1   |
| 2    | LST550    | 50 MESH SCREEN     | 1   |
| 2    | LST580    | 80 MESH SCREEN     | 1   |
| 2    | LST5100   | 100 MESH SCREEN    | 1   |
| 3    | LSTM050H  | 1/2" STRAINER HEAD | 1   |
| 3    | LSTM075H  | 3/4" STRAINER HEAD | 1   |
| 4    | LSTM050BC | CLEAR BOWL         | 1   |
| 4    | LSTM050B  | BLACK BOWL         | 1   |

### STANDARD MESHES & DATA

|               | 30 MESH | 50 MESH | 80 MESH | 100 MESH |
|---------------|---------|---------|---------|----------|
| MICRONS       | 595     | 297     | 177     | 149      |
| WIRE DIAMETER | .012    | .009    | .0055   | .0045    |
| OPENING       | .021    | .011    | .007    | .005     |
| % OPEN AREA   | 40.8    | 30.3    | 31.4    | 30.3     |

## MINI T STRAINERS

### SCREENS

| MESH SIZE | RIB COLOR     |
|-----------|---------------|
| 30 MESH   | FLAME RED     |
| 50 MESH   | GENTIAN BLUE  |
| 80 MESH   | ZINC YELLOW   |
| 100 MESH  | TRAFFIC GREEN |

## 3/4"-1 1/2" T STRAINERS

### FEATURES

- Heavy duty glass reinforced polypropylene
- Clean out plug
- Polypropylene ribbed 316 stainless steel screens
- EPDM gaskets standard, FKM available
- Convenient color coded screens for easy mesh size identification (Refer to chart on next page)



| 3/4"-1" T STRAINERS |  |         |     |  |
|---------------------|--|---------|-----|--|
| PART NO             | DESCRIPTION                                    | MAX PSI | QTY |  |
| LST075-16           | 3/4" X 3/4" FP T STRAINER W/16 MESH SS SCREEN  | 300     | 1   |  |
| LST075-30           | 3/4" X 3/4" FP T STRAINER W/30 MESH SS SCREEN  | 300     | 1   |  |
| LST075-50           | 3/4" X 3/4" FP T STRAINER W/50 MESH SS SCREEN  | 300     | 1   |  |
| LST075-80           | 3/4" X 3/4" FP T STRAINER W/80 MESH SS SCREEN  | 300     | 1   |  |
| LST075-100          | 3/4" X 3/4" FP T STRAINER W/100 MESH SS SCREEN | 300     | 1   |  |
| LST100-16           | 1" X 1" T STRAINER W/16 MESH SS SCREEN         | 300     | 1   |  |
| LST100-30           | 1" X 1" T STRAINER W/30 MESH SS SCREEN         | 300     | 1   |  |
| LST100-50           | 1" X 1" T STRAINER W/50 MESH SS SCREEN         | 300     | 1   |  |
| LST100-80           | 1" X 1" T STRAINER W/80 MESH SS SCREEN         | 300     | 1   |  |
| LST100-100          | 1" X 1" T STRAINER W/100 MESH SS SCREEN        | 300     | 1   |  |

| 1 1/4"-1 1/2" T STRAINERS |   |         |     |  |
|---------------------------|---|---------|-----|--|
| PART NO                   | DESCRIPTION                                       | MAX PSI | QTY |  |
| LST125-16                 | 1 1/4" X 1 1/4" FP T STRAINER W/16 MESH SS SCREEN | 300     | 1   |  |
| LST125-30                 | 1 1/4" X 1 1/4" FP T STRAINER W/30 MESH SS SCREEN | 300     | 1   |  |
| LST125-50                 | 1 1/4" X 1 1/4" FP T STRAINER W/50 MESH SS SCREEN | 300     | 1   |  |
| LST125-80                 | 1 1/4" X 1 1/4" FP T STRAINER W/80 MESH SS SCREEN | 300     | 1   |  |
| LST150-30                 | 1 1/2" X 1 1/2" T STRAINER W/30 MESH SS SCREEN    | 300     | 1   |  |
| LST150-50                 | 1 1/2" X 1 1/2" T STRAINER W/50 MESH SS SCREEN    | 300     | 1   |  |
| LST150-80                 | 1 1/2" X 1 1/2" T STRAINER W/80 MESH SS SCREEN    | 300     | 1   |  |
| LST150-100                | 1 1/2" X 1 1/2" T STRAINER W/100 MESH SS SCREEN   | 300     | 1   |  |

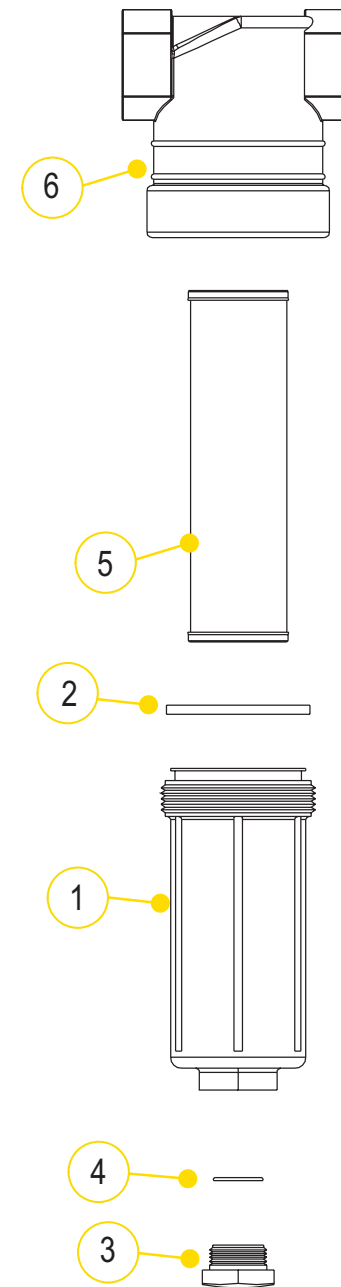

| REPLACEMENT PARTS |           |                                      |     |
|-------------------|-----------|--------------------------------------|-----|
| ITEM              | PART NO   | DESCRIPTION                          | QTY |
| 1                 | LST100-B  | 3/4" & 1" BOWL (CONTAINS #1, #3, #4) | 1   |
| 2                 | LST100-G  | 3/4" & 1" EPDM GASKET                | 1   |
| 2                 | LST100-GV | 3/4" & 1" FKM GASKET                 | 1   |
| 3                 | 12777     | 1/2" PLUG                            | 1   |
| 4                 | UV15163   | EPDM O-RING FOR CLEAN OUT PLUG       | 1   |
| 5                 | LST116    | 16 MESH SCREEN                       | 1   |
| 5                 | LST130    | 30 MESH SCREEN                       | 1   |
| 5                 | LST150    | 50 MESH SCREEN                       | 1   |
| 5                 | LST180    | 80 MESH SCREEN                       | 1   |
| 5                 | LST1100   | 100 MESH SCREEN                      | 1   |
| 6                 | LST075-H  | 3/4" STRAINER HEAD                   | 1   |
| 6                 | LST100-H  | 1" STRAINER HEAD                     | 1   |
| N/S               | LST075-HB | 3/4" STRAINER HEAD, BOWL & GASKET    | 1   |
| N/S               | LST100-HB | 1" STRAINER HEAD, BOWL & GASKET      | 1   |

| REPLACEMENT PARTS |           |  |     |
|-------------------|-----------|--|-----|
| ITEM              | PART NO   | DESCRIPTION                                | QTY |
| 1                 | LST150-B  | 1 1/4" & 1 1/2" BOWL (CONTAINS #1, #3, #4) | 1   |
| 2                 | LST150-G  | 1 1/4" & 1 1/2" EPDM GASKET                | 1   |
| 2                 | LST150-GV | 1 1/4" & 1 1/2" FKM GASKET                 | 1   |
| 3                 | LSQ200-PL | 1" CLEAN OUT PLUG                          | 1   |
| 4                 | LSQ200-R  | EPDM O-RING FOR CLEAN OUT PLUG             | 1   |
| 5                 | LST1516   | 16 MESH SCREEN                             | 1   |
| 5                 | LST1530   | 30 MESH SCREEN                             | 1   |
| 5                 | LST1550   | 50 MESH SCREEN                             | 1   |
| 5                 | LST1580   | 80 MESH SCREEN                             | 1   |
| 5                 | LST15100  | 100 MESH SCREEN                            | 1   |
| 6                 | N/A       | 1 1/4" STRAINER HEAD                       | 1   |
| N/S               | LST125-HB | 1 1/4" STRAINER HEAD, BOWL & GASKET        | 1   |
| N/S               | LST150-HB | 1 1/2" STRAINER HEAD, BOWL & GASKET        | 1   |

| STANDARD MESHES & DATA |         |         |         |         |          |
|------------------------|---------|---------|---------|---------|----------|
|                        | 16 MESH | 30 MESH | 50 MESH | 80 MESH | 100 MESH |
| MICRONS                | 1190    | 595     | 297     | 177     | 149      |
| WIRE DIAMETER          | .018    | .012    | .009    | .0055   | .0045    |
| OPENING                | .044    | .021    | .011    | .007    | .005     |
| % OPEN AREA            | 50.7    | 40.8    | 30.3    | 31.4    | 30.3     |

## 3/4"-1 1/2" T STRAINERS

| SCREENS   |               |
|-----------|---------------|
| MESH SIZE | RIB COLOR     |
| 16 MESH   | BROWN RED     |
| 30 MESH   | FLAME RED     |
| 50 MESH   | GENTIAN BLUE  |
| 80 MESH   | ZINC YELLOW   |
| 100 MESH  | TRAFFIC GREEN |



## 2" T STRAINERS POLY/STAINLESS COMBO

### FEATURES

- Heavy duty glass reinforced polypropylene bowl
- 316 stainless steel head
- Clean out plug
- 316 stainless steel screens
- FKM gaskets



| 2" T STRAINERS POLY/SS COMBO |   |         |     |
|------------------------------|---|---------|-----|
| PART NO                      | DESCRIPTION   | MAX PSI | QTY |
| LST200-10SS                  | 2" X 2" T STRAINER (SS HEAD & POLY BODY) W/10 MESH SCREEN | 300     | 1   |
| LST200-50SS                  | 2" X 2" T STRAINER (SS HEAD & POLY BODY) W/50 MESH SCREEN | 300     | 1   |

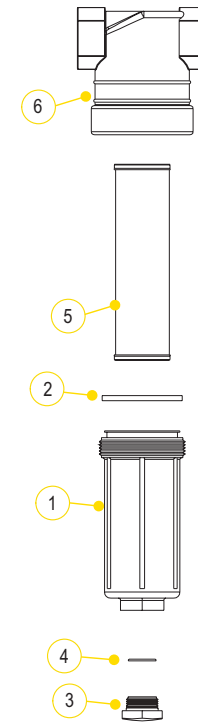

| REPLACEMENT PARTS |            |                                    |     |
|-------------------|------------|------------------------------------|-----|
| ITEM              | PART NO    | DESCRIPTION                        | QTY |
| 1                 | LST200-B   | 2" POLY BOWL (CONTAINS #1, #3, #4) | 1   |
| 2                 | LST200-GV  | 2" FKM GASKET                      | 1   |
| 3                 | LSQ200-PL  | 1" CLEAN OUT PLUG                  | 1   |
| 4                 | LSQ200-RV  | FKM O-RING FOR CLEAN OUT PLUG      | 1   |
| 5                 | LST204SS   | 4 MESH SS SCREEN                   | 1   |
| 5                 | LST206SS   | 6 MESH SS SCREEN                   | 1   |
| 5                 | LST208SS   | 8 MESH SS SCREEN                   | 1   |
| 5                 | LST210SS   | 10 MESH SS SCREEN                  | 1   |
| 5                 | LST216SS   | 16 MESH SS SCREEN                  | 1   |
| 5                 | LST220SS   | 20 MESH SS SCREEN                  | 1   |
| 5                 | LST230SS   | 30 MESH SS SCREEN                  | 1   |
| 5                 | LST250SS   | 50 MESH SS SCREEN                  | 1   |
| 5                 | LST280SS   | 80 MESH SS SCREEN                  | 1   |
| 6                 | LST200-HSS | 2" SS HEAD                         | 1   |

## 2" T STRAINERS POLY/STAINLESS COMBO

## LSQ STRAINERS

### FEATURES

- Precision molded in glass reinforced polypropylene
- Cam lever configuration for easy access for cleaning and servicing
- 3/4" plug in cam lever cap for attaching ball valve for draining or back flushing
- Poly ribbed 316 stainless steel screen
- EPDM lathe cut gasket
- For faster shipping, order in box quantities
- Convenient color coded screens for easy mesh size identification (Refer to chart on next page)



| 1 1/2" LSQ STRAINERS |                                       |         |         |
|----------------------|---------------------------------------|---------|---------|
| PART NO              | DESCRIPTION                           | MAX PSI | LOT QTY |
| LSQ150-B/C           | 1 1/2" X 1 1/2" LSQ STRAINER BODY/CAP | N/A     | 1       |

| 2" LSQ STRAINERS |                                       |         |         |
|------------------|---------------------------------------|---------|---------|
| PART NO          | DESCRIPTION                           | MAX PSI | LOT QTY |
| LSQ200-06        | 2" X 2" LSQ STRAINER W/6 MESH SCREEN  | 100     | 6/BOX   |
| LSQ200-20        | 2" X 2" LSQ STRAINER W/20 MESH SCREEN | 100     | 6/BOX   |
| LSQ200-30        | 2" X 2" LSQ STRAINER W/30 MESH SCREEN | 100     | 6/BOX   |
| LSQ200-50        | 2" X 2" LSQ STRAINER W/50 MESH SCREEN | 100     | 6/BOX   |
| LSQ200-80        | 2" X 2" LSQ STRAINER W/80 MESH SCREEN | 100     | 6/BOX   |

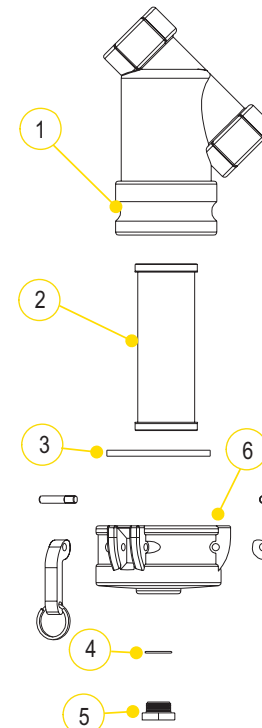

| REPLACEMENT PARTS |            |                                       |     |
|-------------------|------------|---------------------------------------|-----|
| ITEM              | PART NO    | DESCRIPTION                           | QTY |
| 1                 | N/A        | 2" LSQ BODY                           | 1   |
| 2                 | LS206      | 6 MESH SCREEN                         | 1   |
| 2                 | LS212      | 12 MESH SCREEN                        | 1   |
| 2                 | LS220      | 20 MESH SCREEN                        | 1   |
| 2                 | LS230      | 30 MESH SCREEN                        | 1   |
| 2                 | LS250      | 50 MESH SCREEN                        | 1   |
| 2                 | LS280      | 80 MESH SCREEN                        | 1   |
| 2                 | LS2120     | 120 MESH SCREEN                       | 1   |
| 3                 | LSQ150-B/C | 1 1/2" X 1 1/2" LSQ STRAINER BODY/CAP | 1   |
| 3                 | LSQ200-G   | 2" EPDM GASKET                        | 1   |
| 3                 | LSQ200-GV  | 2" FKM GASKET                         | 1   |
| 4                 | LSQ200R1   | O-RING                                | 1   |
| 5                 | N/A        | 3/4" CLEAN OUT PLUG                   | 1   |
| 6                 | LSQ200-C   | 2" CAP (CONTAINS #3-6)                | 1   |
| N/S               | LSQ200-B/C | 2" BODY/CAP (CONTAINS #1, 3-6)        | 1   |

| STANDARD MESHES & DATA |        |        |         |         |         |         |         |         |         |          |          |
|------------------------|--------|--------|---------|---------|---------|---------|---------|---------|---------|----------|----------|
|                        | 6 MESH | 8 MESH | 10 MESH | 12 MESH | 16 MESH | 20 MESH | 30 MESH | 50 MESH | 80 MESH | 100 MESH | 120 MESH |
| MICRONS                | 3360   | 2380   | 2000    | 1680    | 1190    | 841     | 595     | 297     | 177     | 149      | 116      |
| WIRE DIAMETER          | .035   | .028   | .025    | .023    | .018    | .016    | .012    | .009    | .0055   | .0045    | .0037    |
| OPENING                | .132   | .097   | .075    | .060    | .044    | .034    | .021    | .011    | .007    | .005     | .0046    |
| % OPEN AREA            | 62.7   | 60.2   | 56.3    | 51.8    | 50.7    | 46.2    | 40.8    | 30.3    | 31.4    | 30.3     | 30.5     |

## LSQ STRAINERS

### SCREENS

| MESH SIZE | RIB COLOR    |
|-----------|--------------|
| 6 MESH    | WHITE        |
| 12 MESH   | BLACK        |
| 20 MESH   | BEIGE        |
| 30 MESH   | FLAME RED    |
| 50 MESH   | GENTIAN BLUE |
| 80 MESH   | ZINC YELLOW  |
| 120 MESH  | BLACK        |

## 1/2"-1 1/4" Y STRAINERS

### FEATURES

- Heavy duty glass reinforced polypropylene
- Corrosion resistant
- Easy grip end cap
- Heavy duty end cap threads
- Clean out plug
- Polypropylene ribbed 316 stainless steel screens
- EPDM gaskets
- Convenient color coded screens for easy mesh size identification (Refer to chart on next page)



| 1/2" - 3/4" Y STRAINERS |   |         |     |
|-------------------------|---|---------|-----|
| PART NO                 | DESCRIPTION                                   | MAX PSI | QTY |
| LS050-20                | 1/2" X 1/2" FP Y STRAINER W/20 MESH SS SCREEN | 225     | 1   |
| LS050-40                | 1/2" X 1/2" FP Y STRAINER W/40 MESH SS SCREEN | 225     | 1   |
| LS050-80                | 1/2" X 1/2" FP Y STRAINER W/80 MESH SS SCREEN | 225     | 1   |
| LS075-20                | 3/4" X 3/4" Y STRAINER W/20 MESH SS SCREEN    | 225     | 1   |
| LS075-40                | 3/4" X 3/4" Y STRAINER W/40 MESH SS SCREEN    | 225     | 1   |
| LS075-80                | 3/4" X 3/4" Y STRAINER W/80 MESH SS SCREEN    | 225     | 1   |



| 1" - 1 1/4" Y STRAINERS |  |         |     |
|-------------------------|--|---------|-----|
| PART NO                 | DESCRIPTION                                    | MAX PSI | QTY |
| LS100-20                | 1" X 1" Y STRAINER W/20 MESH SS SCREEN         | 200     | 1   |
| LS100-40                | 1" X 1" Y STRAINER W/40 MESH SS SCREEN         | 200     | 1   |
| LS100-80                | 1" X 1" Y STRAINER W/80 MESH SS SCREEN         | 200     | 1   |
| LS125-20                | 1 1/4" X 1 1/4" Y STRAINER W/20 MESH SS SCREEN | 200     | 1   |
| LS125-40                | 1 1/4" X 1 1/4" Y STRAINER W/40 MESH SS SCREEN | 200     | 1   |
| LS125-80                | 1 1/4" X 1 1/4" Y STRAINER W/80 MESH SS SCREEN | 200     | 1   |

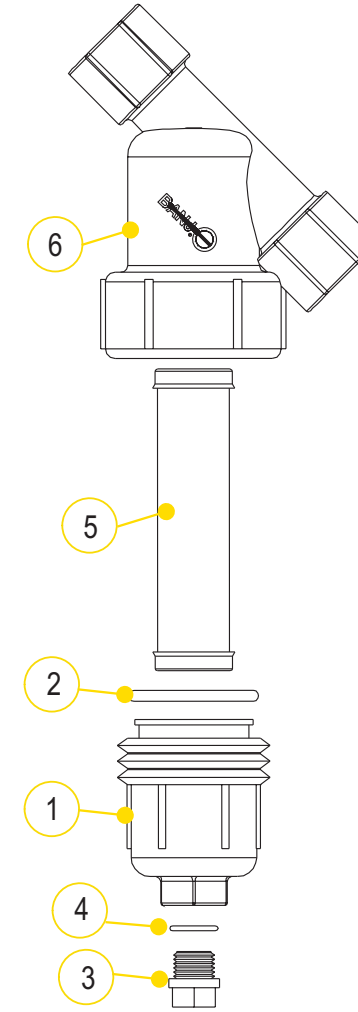

| REPLACEMENT PARTS |           |   |     |
|-------------------|-----------|---|-----|
| ITEM              | PART NO   | DESCRIPTION                             | QTY |
| 1                 | N/A       | 1/2"-3/4" END CAP (CONTAINS #1, #3, #4) | 1   |
| 2                 | LS075-G   | 1/2"-3/4" O-RING                        | 1   |
| 3                 | 12723     | 1/4" DRAIN PLUG (FITS 1/2"-3/4")        | 1   |
| 4                 | 12724     | 1/2"-3/4" EPDM O-RING FOR DRAIN PLUG    | 1   |
| 5                 | LS720     | 1/2"-3/4" 20 MESH SCREEN                | 1   |
| 5                 | LS740     | 1/2"-3/4" 40 MESH SCREEN                | 1   |
| 5                 | LS780     | 1/2"-3/4" 80 MESH SCREEN                | 1   |
| 6                 | N/A       | 3/4" Y BODY                             | 1   |
| N/S               | LS050B/C1 | 1/2" Y BODY, CAP & GASKET               | 1   |
| N/S               | LS075B/C1 | 3/4" Y BODY, CAP & GASKET               | 1   |

| REPLACEMENT PARTS |           |   |     |
|-------------------|-----------|---|-----|
| ITEM              | PART NO   | DESCRIPTION                             | QTY |
| 1                 | LS100-C1  | 1"-1 1/4" END CAP (CONTAINS #1, #3, #4) | 1   |
| 2                 | LS100-G   | 1"-1 1/4" O-RING                        | 1   |
| 2                 | LS100-GV  | 1"-1 1/4" FKM GASKET                    | 1   |
| 3                 | 12777     | 1/2" PLUG (FITS 1"-1 1/4")              | 1   |
| 4                 | UV15163   | EPDM O-RING FOR DRAIN PLUG              | 1   |
| 4                 | UV15163V  | FKM O-RING FOR DRAIN PLUG               | 1   |
| 5                 | LS120     | 1"-1 1/4" 20 MESH SCREEN                | 1   |
| 5                 | LS140     | 1"-1 1/4" 40 MESH SCREEN                | 1   |
| 5                 | LS180     | 1"-1 1/4" 80 MESH SCREEN                | 1   |
| 6                 | N/A       | 1" Y BODY                               | 1   |
| 6                 | N/A       | 1 1/4" Y BODY                           | 1   |
| N/S               | LS100B/C1 | 1" Y BODY, CAP & GASKET                 | 1   |
| N/S               | LS125B/C1 | 1 1/4" Y BODY, CAP & GASKET             | 1   |

## 1/2"-1 1/4" Y STRAINERS

| SCREENS   |               |
|-----------|---------------|
| MESH SIZE | RIB COLOR     |
| 6 MESH    | WHITE         |
| 12 MESH   | BLACK         |
| 20 MESH   | BEIGE         |
| 30 MESH   | FLAME RED     |
| 40 MESH   | BROWN         |
| 50 MESH   | GENTIAN BLUE  |
| 60 MESH   | GENTIAN BLUE  |
| 80 MESH   | ZINC YELLOW   |
| 100 MESH  | TRAFFIC GREEN |
| 120 MESH  | BLACK         |

| STANDARD MESHES & DATA |        |        |         |         |         |         |         |         |         |          |          |
|------------------------|--------|--------|---------|---------|---------|---------|---------|---------|---------|----------|----------|
|                        | 6 MESH | 8 MESH | 10 MESH | 12 MESH | 16 MESH | 20 MESH | 30 MESH | 50 MESH | 80 MESH | 100 MESH | 120 MESH |
| MICRONS                | 3360   | 2380   | 2000    | 1680    | 1190    | 841     | 595     | 297     | 177     | 149      | 116      |
| WIRE DIAMETER          | .035   | .028   | .025    | .023    | .018    | .016    | .012    | .009    | .0055   | .0045    | .0037    |
| OPENING                | .132   | .097   | .075    | .060    | .044    | .034    | .021    | .011    | .007    | .005     | .0046    |
| % OPEN AREA            | 62.7   | 60.2   | 56.3    | 51.8    | 50.7    | 46.2    | 40.8    | 30.3    | 31.4    | 30.3     | 30.5     |



## 1½"-2" Y STRAINERS

### FEATURES

- Heavy duty glass reinforced polypropylene
- Corrosion resistant
- Easy grip end cap
- Heavy duty end cap threads
- Clean out plug
- Polypropylene ribbed 316 stainless steel screens
- EPDM gaskets
- Convenient color coded screens for easy mesh size identification (Refer to chart on next page)



| 1½" Y STRAINERS |   |         |     |
|-----------------|---|---------|-----|
| PART NO         | DESCRIPTION                               | MAX PSI | QTY |
| LS150-06        | 1½" X 1½" Y STRAINER W/6 MESH SS SCREEN   | 150     | 1   |
| LS150-12        | 1½" X 1½" Y STRAINER W/12 MESH SS SCREEN  | 150     | 1   |
| LS150-20        | 1½" X 1½" Y STRAINER W/20 MESH SS SCREEN  | 150     | 1   |
| LS150-30        | 1½" X 1½" Y STRAINER W/30 MESH SS SCREEN  | 150     | 1   |
| LS150-50        | 1½" X 1½" Y STRAINER W/50 MESH SS SCREEN  | 150     | 1   |
| LS150-80        | 1½" X 1½" Y STRAINER W/80 MESH SS SCREEN  | 150     | 1   |
| LS150-120       | 1½" X 1½" Y STRAINER W/120 MESH SS SCREEN | 150     | 1   |



| 2" Y STRAINERS |   |         |         |
|----------------|---|---------|---------|
| PART NO        | DESCRIPTION   | MAX PSI | LOT QTY |
| LS200-06       | 2" X 2" Y STRAINER W/6 MESH POLY RIBBED SS SCREEN   | 150     | 1       |
| LS200-12       | 2" X 2" Y STRAINER W/12 MESH POLY RIBBED SS SCREEN  | 150     | 1       |
| LS200-20       | 2" X 2" Y STRAINER W/20 MESH POLY RIBBED SS SCREEN  | 150     | 1       |
| LS200-30       | 2" X 2" Y STRAINER W/30 MESH POLY RIBBED SS SCREEN  | 150     | 1       |
| LS200-50       | 2" X 2" Y STRAINER W/50 MESH POLY RIBBED SS SCREEN  | 150     | 5       |
| LS200-80       | 2" X 2" Y STRAINER W/80 MESH POLY RIBBED SS SCREEN  | 150     | 1       |
| LS200-100      | 2" X 2" Y STRAINER W/100 MESH POLY RIBBED SS SCREEN | 150     | 1       |
| LS200-120      | 2" X 2" Y STRAINER W/120 MESH POLY RIBBED SS SCREEN | 150     | 1       |

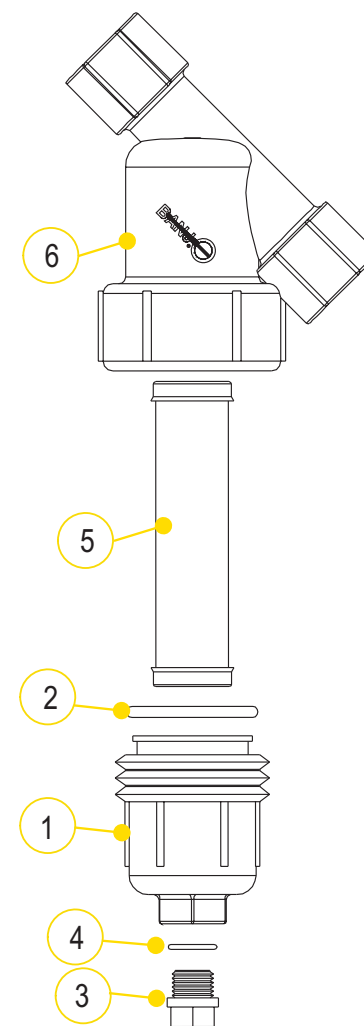

| REPLACEMENT PARTS |           |  |     |
|-------------------|-----------|--|-----|
| ITEM              | PART NO   | DESCRIPTION                            | QTY |
| 1                 | LS150-C   | 1½" - 2" END CAP (CONTAINS #1, #3, #4) | 1   |
| 2                 | LS150-G   | 1½"-2" O-RING                          | 1   |
| 2                 | LS150-GV  | 1½"-2" FKM GASKET                      | 1   |
| 3                 | LSQ200-PL | 1" DRAIN PLUG (FITS 1½" - 2")          | 1   |
| 4                 | LSQ200-RV | 1½"-2" FKM O-RING FOR DRAIN PLUG       | 1   |
| 5                 | LS206     | 1½"-2" 6 MESH SCREEN                   | 1   |
| 5                 | LS212     | 1½"-2" 12 MESH SCREEN                  | 1   |
| 5                 | LS220     | 1½"-2" 20 MESH SCREEN                  | 1   |
| 5                 | LS230     | 1½"-2" 30 MESH SCREEN                  | 1   |
| 5                 | LS250     | 1½"-2" 50 MESH SCREEN                  | 1   |
| 5                 | LS280     | 1½"-2" 80 MESH SCREEN                  | 1   |
| 5                 | LS2100    | 1½"-2" 100 MESH SCREEN                 | 1   |
| 5                 | LS2120    | 1½"-2" 120 MESH SCREEN                 | 1   |
| 5                 | LS250P    | 1½"-2" 50 MESH ALL POLY SCREEN         | 1   |
| 6                 | N/A       | 1½" Y BODY                             | 1   |
| 6                 | N/A       | 2" Y BODY                              | 1   |
| N/S               | LS150B/C  | 1½" Y BODY, CAP & GASKET               | 1   |
| N/S               | LS200B/C  | 2" Y BODY, CAP & GASKET                | 1   |

## 1½"-2" Y STRAINERS

| SCREENS   |               |
|-----------|---------------|
| MESH SIZE | RIB COLOR     |
| 6 MESH    | WHITE         |
| 12 MESH   | BLACK         |
| 20 MESH   | BEIGE         |
| 30 MESH   | FLAME RED     |
| 40 MESH   | BROWN         |
| 50 MESH   | GENTIAN BLUE  |
| 80 MESH   | ZINC YELLOW   |
| 100 MESH  | TRAFFIC GREEN |
| 120 MESH  | BLACK         |

| STANDARD MESHES & DATA |        |        |         |         |         |         |         |          |          |
|------------------------|--------|--------|---------|---------|---------|---------|---------|----------|----------|
|                        | 6 MESH | 8 MESH | 12 MESH | 20 MESH | 30 MESH | 50 MESH | 80 MESH | 100 MESH | 120 MESH |
| MICRONS                | 3360   | 2380   | 1680    | 841     | 595     | 297     | 177     | 149      | 116      |
| WIRE DIAMETER          | .035   | .028   | .023    | .016    | .012    | .009    | .0055   | .0045    | .0037    |
| OPENING                | .132   | .097   | .060    | .034    | .021    | .011    | .007    | .005     | .0046    |
| % OPEN AREA            | 62.7   | 60.2   | 51.8    | 46.2    | 40.8    | 30.3    | 31.4    | 30.3     | 30.5     |

## 3" Y STRAINERS

### FEATURES

- Heavy duty glass reinforced polypropylene
- Corrosion resistant
- High volume
- Heavy duty end cap threads
- ½" clean out plug
- 304 stainless steel screens
- EPDM gaskets
- Warning: to be used on suction side or non-pressure side in all applications



### 3" Y STRAINERS

| PART NO   | DESCRIPTION                         | MAX PSI | LOT QTY |
|-----------|-------------------------------------|---------|---------|
| LSM300-04 | 3" X 3" Y STRAINER W/4 MESH SCREEN  | 75      | 1       |
| LSM300-08 | 3" X 3" Y STRAINER W/8 MESH SCREEN  | 75      | 1       |
| LSM300-12 | 3" X 3" Y STRAINER W/12 MESH SCREEN | 75      | 1       |
| LSM300-20 | 3" X 3" Y STRAINER W/20 MESH SCREEN | 75      | 1       |
| LSM300-50 | 3" X 3" Y STRAINER W/50 MESH SCREEN | 75      | 1       |

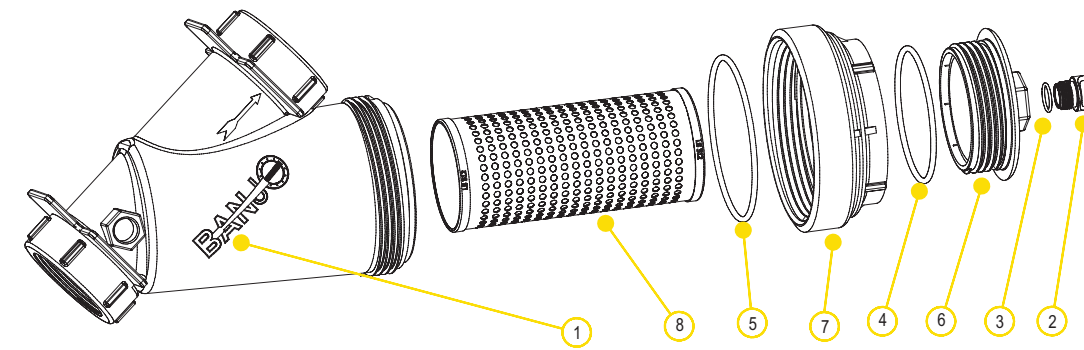

### REPLACEMENT PARTS

| ITEM | PART NO    | DESCRIPTION                         | QTY |
|------|------------|-------------------------------------|-----|
| 1    | MLS300B1   | 3" BODY                             | 1   |
| 2    | 13777      | ¾" PLUG                             | 1   |
| 3    | 13778      | O-RING                              | 1   |
| 4    | MLS300ECG  | EPDM END CAP GASKET                 | 1   |
| 4    | MLS300ECGV | FKM CAP GASKET                      | 1   |
| 5    | MLS300G    | EPDM CAP GASKET                     | 1   |
| 6    | LS300EC    | END CAP ONLY (PLUG SOLD SEPARATELY) | 1   |
| 7    | MLS300CAP  | 3" CAP                              | 1   |
| 8    | LS304      | 4 MESH SCREEN                       | 1   |
| 8    | LS308      | 8 MESH SCREEN                       | 1   |
| 8    | LS312      | 12 MESH SCREEN                      | 1   |
| 8    | LS320      | 20 MESH SCREEN                      | 1   |
| 8    | LS350      | 50 MESH SCREEN                      | 1   |

## 3" Y STRAINERS

- 304 stainless steel screens

## 3" Y STAINLESS STEEL STRAINERS

### FEATURES

- Heavy duty stainless steel
- Corrosion resistant
- High volume
- Heavy duty end cap threads
- ½" clean out plug
- 304 stainless steel screens
- EPDM gaskets standard, FKM available
- Maximum operating pressure 225 psi
- Warning: to be used on suction side or non-pressure side in all applications



### 3" Y STRAINERS

| PART NO   | DESCRIPTION               | QTY |
|-----------|---------------------------|-----|
| LSS300-BC | 3" SS BODY, CAP & GASKETS | 1   |
| LSS300-C  | 3" SS CAP                 | 1   |
| LSS300-S  | EPDM SCREEN SEAL          | 1   |
| LSS300-SV | FKM SCREEN SEAL           | 1   |
| LSS300-G  | EPDM CAP GASKET           | 1   |
| LSS300-GV | FKM CAP GASKET            | 1   |

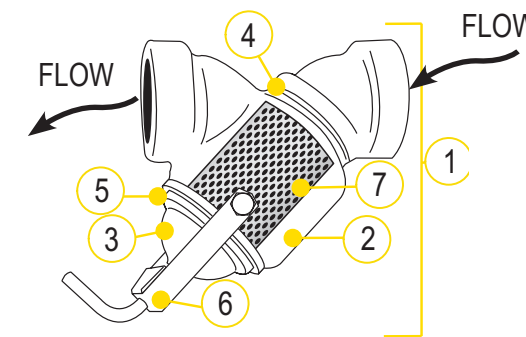

### REPLACEMENT PARTS

| ITEM | PART NO   | DESCRIPTION               | QTY |
|------|-----------|---------------------------|-----|
| 1    | LSS300-BC | 3" SS BODY, CAP & GASKETS | 1   |
| 2    | N/A       | 3" SS BODY                | 1   |
| 3    | LSS300-C  | 3" SS CAP                 | 1   |
| 4    | LSS300-S  | EPDM SCREEN SEAL          | 1   |
| 4    | LSS300-SV | FKM SCREEN SEAL           | 1   |
| 5    | LSS300-G  | EPDM CAP GASKET           | 1   |
| 5    | LSS300-GV | FKM CAP GASKET            | 1   |
| 6    | LSS300-H  | HANDLE/CLAMP ASSEMBLY     | 1   |
| 7    | LSS306    | 6 MESH SS SCREEN          | 1   |
| 7    | LSS308    | 8 MESH SS SCREEN          | 1   |
| 7    | LSS312    | 12 MESH SS SCREEN         | 1   |
| 7    | LSS320    | 20 MESH SS SCREEN         | 1   |
| 7    | LSS330    | 30 MESH SS SCREEN         | 1   |
| 7    | LSS350    | 50 MESH SS SCREEN         | 1   |

## 3" Y STAINLESS STEEL STRAINERS

- 304 stainless steel screens



**PUMP ACCESSORIES**  
PAGES 95

SUCTION BASKET STRAINERS  
BASE PLATES

**2" POLY PUMPS**  
PAGES 96 - 109

GAS ENGINE PUMPS  
PUMP ONLY/ BEARING PEDESTAL  
WET SEAL WITH GAS ENGINE  
ELECTRIC MOTOR DRIVEN  
HYDRAULIC MOTOR DRIVEN  
MANIFOLD

**3" POLY PUMPS**  
PAGES 110- 119

GAS ENGINE PUMPS  
PUMP ONLY/ BEARING PEDESTAL  
MANIFOLD  
HYDRAULIC MOTOR DRIVEN  
WET SEAL WITH GAS ENGINE

**1½" & 2" CAST IRON PUMPS**  
PAGES 120 - 127

GAS ENGINE PUMPS  
PUMP ONLY/ BEARING PEDESTAL  
WET SEALS  
ELECTRIC MOTOR DRIVEN  
HYDRAULIC MOTOR DRIVEN

**2" CAST IRON 222  
SERIES PUMPS**  
PAGES 128- 131

GAS ENGINE PUMPS  
PUMP ONLY/ BEARING PEDESTAL  
HYDRAULIC MOTOR DRIVEN  
ELECTRIC MOTOR DRIVEN  
MANIFOLD WET SEAL

**3" CAST IRON PUMPS**  
PAGES 132 - 137

GAS ENGINE PUMPS  
PUMP ONLY/ BEARING PEDESTAL  
WET SEALS  
HYDRAULIC MOTOR DRIVEN

**3" CAST IRON 333  
SERIES PUMPS**  
PAGES 138 - 139

GAS ENGINE PUMPS  
PUMP ONLY/ BEARING PEDESTAL  
ELECTRIC MOTOR DRIVEN

**3" CAST IRON MANIFOLD WET  
SEAL M332 SERIES PUMPS**  
PAGES 140 - 143

GAS ENGINE PUMPS  
PUMP ONLY/ BEARING PEDESTAL  
ELECTRIC MOTOR DRIVEN  
HYDRAULIC MOTOR DRIVEN

**4" CAST IRON 444  
SERIES PUMPS**  
PAGES 144 - 145

GAS ENGINE PUMPS  
PUMP ONLY

**2" & 3" STAINLESS STEEL  
PUMPS**  
PAGES 146- 153

GAS ENGINE PUMPS  
PUMP ONLY/ BEARING PEDESTAL  
ELECTRIC MOTOR DRIVEN  
HYDRAULIC MOTOR DRIVEN

## SUCTION BASKET STRAINERS

### FEATURES

- Made of polyethylene
- Prevents plugging and damage to pump while suctioning from streams or ponds.



### SUCTION BASKET STRAINERS

| PART NO | DESCRIPTION                  | QTY |
|---------|------------------------------|-----|
| 200SBS  | 2" FEMALE THREAD POLY BASKET | 1   |
| 300SBS  | 3" FEMALE THREAD POLY BASKET | 1   |

## BASE PLATE ASSEMBLY

### FEATURES

- Universal fit for 1½", 2" and 3" polypropylene or cast iron pumps



### BASE PLATE ASSEMBLY

| PART NO | DESCRIPTION  | QTY |
|---------|--|-----|
| 18700   | BASE PLATE ASSEMBLY INCLUDES PLATE, COUPLING GUARD, BOLT BAG AND SHIMS | 1   |

## 2" POLY PUMPS

### FEATURES

- Precision molded construction
- Lightweight
- Corrosion resistant
- Superior design
- Low maintenance
- EPDM standard, FKM available
- Engine warranty service available at authorized Briggs & Stratton® and Honda® dealers

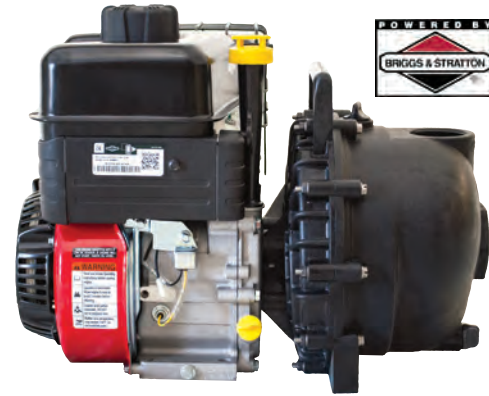

| 2" POLY PUMPS W/GAS ENGINES |  |     |     |          |  |
|-----------------------------|--|-----|-----|----------|--|
| PART NO                     | DESCRIPTION  | HP  | QTY | SKID QTY |  |
| 200PH-5                     | 2" POLY PUMP W/5.5 HP HONDA® ENGINE  | 5.5 | 1   | 12       |  |
| 200PH-5E                    | 2" POLY PUMP W/5.5 HP HONDA® ENGINE W/ ELECTRIC START                          | 5.5 | 1   | 12       |  |
| 200PH-5V                    | 2" POLY PUMP W/5.5 HP HONDA® ENGINE W/FKM & 316 SS SEAL                        | 5.5 | 1   | 12       |  |
| 200PH6                      | 2" POLY PUMP W/6.5 HP HONDA® ENGINE  | 6.5 | 1   | 12       |  |
| 200P6PRO                    | 2" POLY PUMP W/6.5 HP BRIGGS & STRATTON® ENGINE PRO SERIES                     | 6.5 | 1   | 12       |  |
| 200P6PROE                   | 2" POLY PUMP W/6.5 HP BRIGGS & STRATTON® ENGINE PRO SERIES W/ELECTRIC START    | 6.5 | 1   | 12       |  |
| 200P6PROV                   | 2" POLY PUMP W/6.5 HP BRIGGS & STRATTON® ENGINE PRO SERIES W/FKM & 316 SS SEAL | 6.5 | 1   | 12       |  |



WARNING! DO NOT RUN PUMP DRY, RESTRICT OR REDUCE PORT SIZES OR DEAD HEAD PUMP



WARNING! DO NOT USE WITH FLAMMABLE LIQUIDS



| 2" POLY PUMP BEARING PEDESTALS |  |     |     |          |  |
|--------------------------------|--|-----|-----|----------|--|
| PART NO                        | DESCRIPTION  | HP  | QTY | SKID QTY |  |
| 200PB                          | 2" POLY BEARING PEDESTAL W/ 3/4" SHAFT & 3 VANE IMPELLER                     | N/A | 1   | 18       |  |
| 205PB                          | 2" POLY BEARING PEDESTAL W/ 3/4" SHAFT & 5 VANE IMPELLER                     | N/A | 1   | 18       |  |
| 205PB-V                        | 2" POLY BEARING PEDESTAL W/ 3/4" SHAFT & 5 VANE IMPELLER W/FKM & 316 SS SEAL | N/A | 1   | 18       |  |



| 2" POLY PUMP ONLYS |   |     |     |          |  |
|--------------------|---|-----|-----|----------|--|
| PART NO            | DESCRIPTION   | HP  | QTY | SKID QTY |  |
| 200PO              | 2" POLY PUMP ONLY* W/ 3 & 5 VANE IMPELLER                     | N/A | 1   | 27       |  |
| 200PO-V            | 2" POLY PUMP ONLY* W/ 3 & 5 VANE IMPELLER W/FKM & 316 SS SEAL | N/A | 1   | 27       |  |

Note: Requires 3/4" shaft on motor

## 2" POLY PUMPS

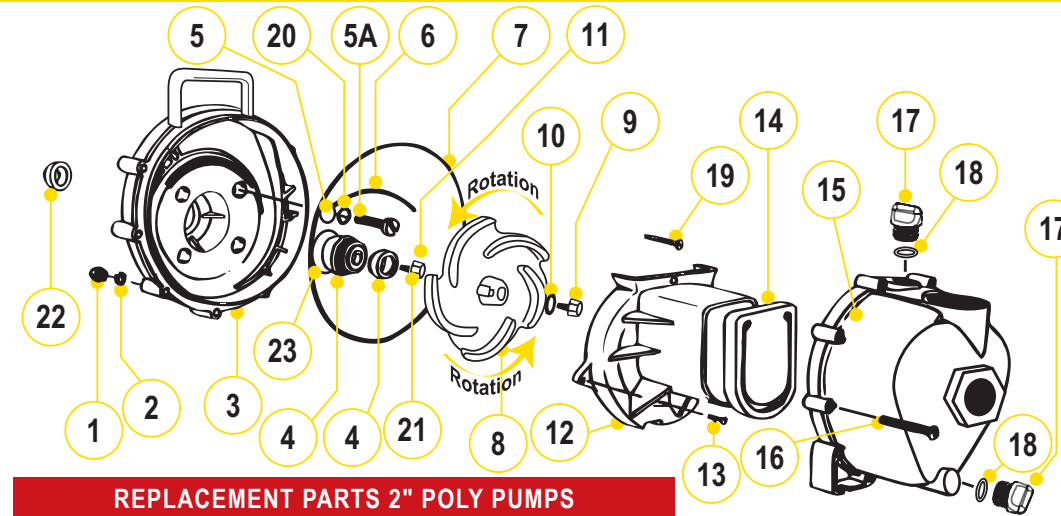

### REPLACEMENT PARTS 2" POLY PUMPS

| ITEM | PART NO  | DESCRIPTION  | QTY |
|------|----------|--|-----|
| 1    | V07019   | SS BODY NUTS   | 10  |
| 2    | V07018   | SS LOCK WASHERS  | 10  |
| 3    | 12703A   | POLY PUMP REAR BRACKET   | 1   |
| 4    | 12713    | SEAL ASSEMBLY  | 1   |
| 4    | 12713V   | FKM SEAL ASSEMBLY  | 1   |
| 5    | 12717    | O-RING FOR SCREW HEAD  | 4   |
| 5    | 12717V   | FKM O-RING FOR SCREW HEAD  | 4   |
| 5A   | 12715A   | SS BRACKET SCREWS  | 4   |
| 6    | 12754    | O-RING SEGMENT   | 1   |
| 6    | 12754V   | FKM O-RING SEGMENT   | 1   |
| 7    | 12719A   | BODY O-RING  | 1   |
| 7    | 12719AV  | FKM BODY O-RING  | 1   |
| 8    | 12772    | 5 VANE IMPELLER  | 1   |
| 8    | 12771A   | 3 VANE IMPELLER  | 1   |
| 9    | 12765A   | SS IMPELLER BOLT   | 1   |
| 10   | A204     | O-RING   | 1   |
| 10   | A204V    | FKM O-RING   | 1   |
| 11   | 12775A   | IMPELLER HEX NUT   | 1   |
| 12   | 12702A   | POLY PUMP VOLUTE   | 1   |
| 13   | 12725    | SS VOLUTE SCREWS   | 1   |
| 14   | 12705    | POLY PUMP CHECK VALVE  | 1   |
| 14   | 12705V   | FKM CHECK VALVE  | 1   |
| 15   | 12712A   | BODY ASSEMBLY  | 1   |
| 16   | 12720    | SS BODY SCREWS   | 10  |
| 17   | 12777    | 1/2" PLUG  | 2   |
| 18   | UV15163  | PRIME/DRAIN PLUG O-RING  | 2   |
| 18   | UV15163V | FKM PRIME/DRAIN PLUG O-RING                                      | 2   |
| 19   | 12900    | SS UPPER VOLUTE SCREW  | 1   |
| 20   | 12901    | SS REAR BRACKET WASHER   | 4   |
| 21   | 12902A   | IMPELLER KEY   | 1   |
| 22   | 12716    | POLY PUMP SLINGER  | 1   |
| 23   | 12710    | O-RING FOR SEAL ASSEMBLY   | 1   |
| 23   | 12710V   | FKM O-RING FOR SEAL ASSEMBLY                                     | 1   |
| N/S  | 12882A   | BEARING PEDESTAL   | 1   |
| N/S  | 12099    | 7/16"-14 X 1.25" HHCS  | 1   |
| KIT  | 12000A   | POLY PUMP EPDM REPAIR KIT (ITEMS 4-8, 10, 14, 18, 21-23 & 12099) | 1   |
| KIT  | 12000AV  | POLY PUMP FKM REPAIR KIT (ITEMS 4-8, 10, 14, 18, 21-23 & 12099)  | 1   |
| KIT  | 12999A   | PUMP SEAL/O-RING KIT (ITEMS 5-7, 10, 18, 22, 23 & 12099)         | 1   |
| KIT  | 12999AV  | FKM PUMP SEAL/O-RING KIT (ITEMS 5-7, 10, 18, 22, 23 & 12099)     | 1   |

### KITS 2" POLY PUMPS

| PART NO   | REPAIR KIT NO | SEAL KIT NO |
|-----------|---------------|-------------|
| 200PH-5   | 12000A        | 12999A      |
| 200PH-5E  | 12000A        | 12999A      |
| 200PH-5V  | 12000AV       | 12999AV     |
| 200PH6    | 12000A        | 12999A      |
| 200P6PRO  | 12000A        | 12999A      |
| 200P6PROE | 12000A        | 12999A      |
| 200P6PROV | 12000AV       | 12999AV     |
| 200PB     | 12000A        | 12999A      |
| 205PB     | 12000A        | 12999A      |
| 205PB-V   | 12000AV       | 12999AV     |
| 200PO     | 12000A        | 12999A      |
| 200PO-V   | 12000AV       | 12999AV     |

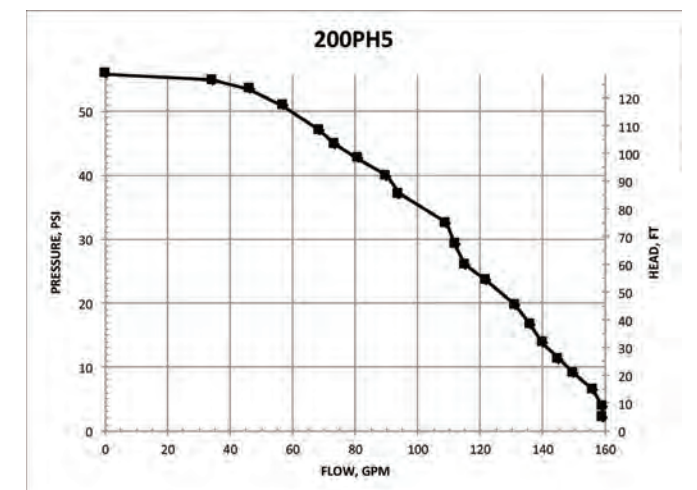
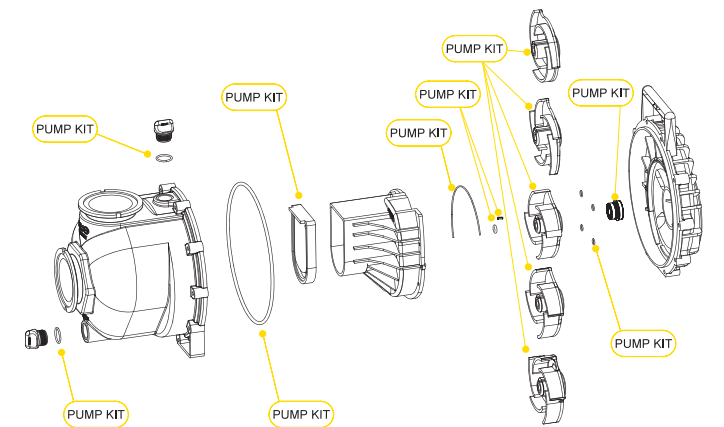



## 2" POLY WET SEAL PUMPS

## 2" POLY WET SEAL PUMPS

### FEATURES

- Run dry capability
- Double seal contained in ethylene glycol reservoir. Carbon ceramic seal faces with stainless steel cup and spring with EPDM rubber.
- Pump end separated from engine
- V-shaped for quicker priming
- Engine warranty service available at authorized Briggs & Stratton® and Honda® dealers

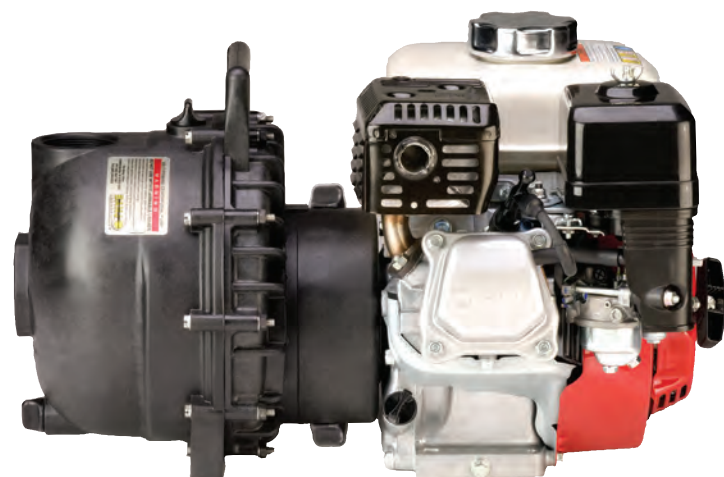

### 2" POLY WET SEAL PUMPS W/GAS ENGINES

| PART NO | DESCRIPTION                                  | HP  | QTY | SKID QTY |
|---------|--|-----|-----|----------|
| 200PH5W | 2" POLY WET SEAL PUMP W/5.5 HP HONDA® ENGINE | 5.5 | 1   | 12       |



WARNING! DO NOT USE WITH FLAMMABLE LIQUIDS



### 2" POLY WET SEAL PUMP ONLY

| PART NO | DESCRIPTION   | HP  | QTY | SKID QTY |
|---------|---|-----|-----|----------|
| 205POW  | 2" POLY WET SEAL PUMP ONLY, 5 VANE IMPELLER WITH EPDM SEALS | N/A | 1   | 27       |

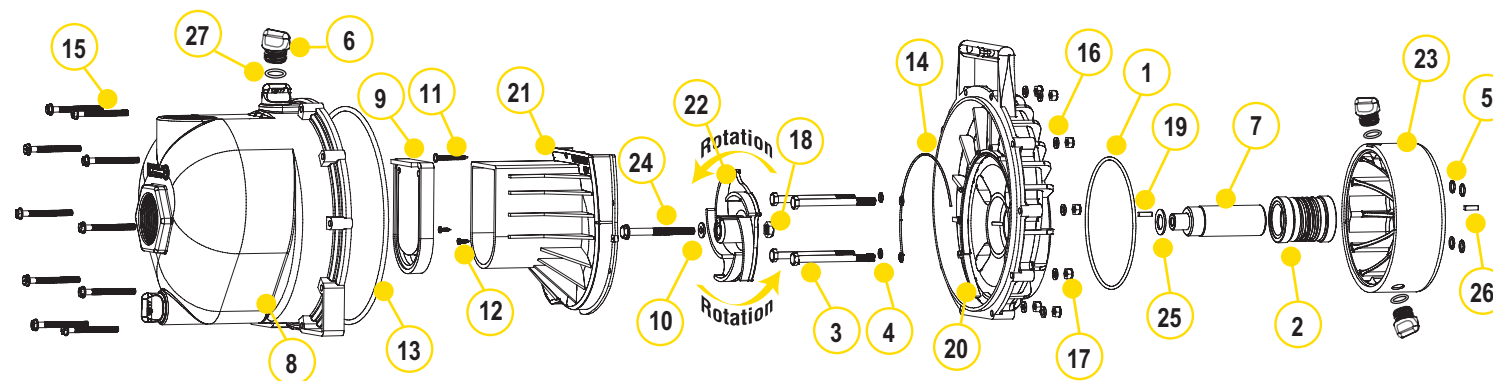

### REPLACEMENT PARTS 2" POLY PUMPS

| ITEM | PART NO | DESCRIPTION                    | QTY |
|------|---------|--------------------------------|-----|
| 1    | 13719   | O-RING                         | 1   |
| 2    | 15035E  | EPDM MECHANICAL SEAL ASSEMBLY  | 1   |
| 3    | 13034   | 5/16" -24 X 3 3/4" HHCS        | 4   |
| 4    | 12717   | O-RING FOR BRACKET SCREW       | 4   |
| 5    | 12709   | O-RING                         | 4   |
| 6    | 12777   | 1/2" PLUG                      | 4   |
| 7    | 12155   | ADAPTER SHAFT                  | 1   |
| 8    | 12712A  | BODY ASSEMBLY                  | 1   |
| 9    | 12705   | CHECK VALVE                    | 1   |
| 10   | A204    | IMPELLER BOLT GASKET           | 1   |
| 11   | 12900   | #10 X 1 1/2" PPH SMS           | 1   |
| 12   | 12725   | #6 X 1/2" PPH SMS              | 2   |
| 13   | 12719A  | BODY O-RING                    | 1   |
| 14   | 12754   | O-RING SEGMENT                 | 1   |
| 15   | 12720   | 1/4" - 20 X 2 1/2" SL IND HWHS | 10  |
| 16   | V07018  | 1/4" LOCK WASHER               | 10  |
| 17   | V07019  | 1/4" - 20 HEX NUT              | 10  |
| 18   | 12775A  | 7/16" - 14 HEX NUT             | 1   |
| 19   | 12902A  | 3/16" SQ. X 5/8" KEY           | 2   |
| 20   | 12707W  | WET SEAL REAR BRACKET          | 1   |
| 21   | 12702A  | VOLUTE                         | 1   |
| 22   | 12772   | 5 VANE IMPELLER                | 1   |
| 23   | 12202W  | WET SEAL RESERVOIR             | 1   |
| 24   | 12766   | 5/16" - 24 X 3 1/4" HFS        | 1   |
| 25   | CV10175 | GASKET                         | 1   |
| 26   | 12902A  | 1/4" SQ. 3/4" KEY STOCK        | 1   |
| 27   | UV15163 | O-RING FOR DRAIN PLUG          | 4   |

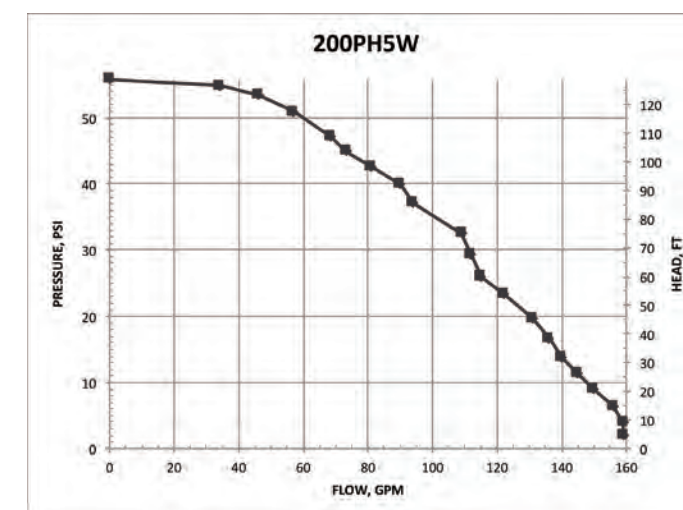

## 2" POLY PUMPS WITH ELECTRIC MOTORS

### FEATURES

- Additional drive unit protection with added 1" spacer for ultimate protection
- The "Super Slinger" included for even more drive unit protection (not shown)

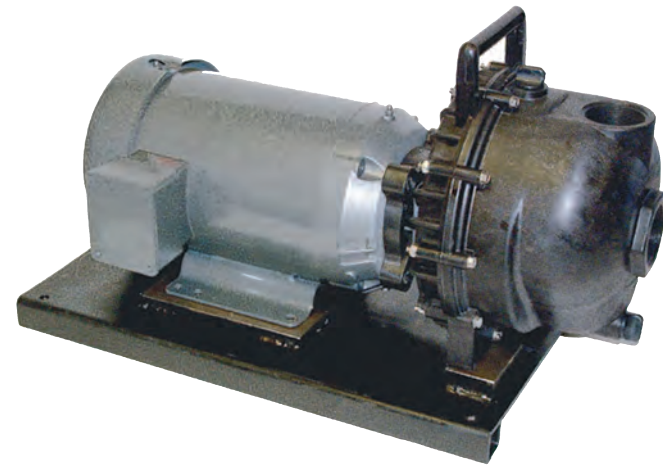

### 2" POLY PUMPS W/ELECTRIC MOTORS

| PART NO   | DESCRIPTION  | HP | QTY | SKID QTY |
|-----------|--|----|-----|----------|
| 234PPE5   | 2" POLY PUMP W/5 HP THREE PHASE ELECTRIC MOTOR W/ EPDM ELASTOMERS  | 5  | 1   | 3        |
| 234PPE5V  | 2" POLY PUMP W/5 HP THREE PHASE ELECTRIC MOTOR W/FKM ELASTOMERS    | 5  | 1   | 3        |
| 234PPE51  | 2" POLY PUMP W/5 HP SINGLE PHASE ELECTRIC MOTOR W/ EPDM ELASTOMERS | 5  | 1   | 3        |
| 234PPE51V | 2" POLY PUMP W/5 HP SINGLE PHASE ELECTRIC MOTOR W/FKM ELASTOMERS   | 5  | 1   | 3        |



WARNING! DO NOT RUN PUMP DRY, RESTRICT OR REDUCE PORT SIZES OR DEAD HEAD PUMP



WARNING! DO NOT USE WITH FLAMMABLE LIQUIDS

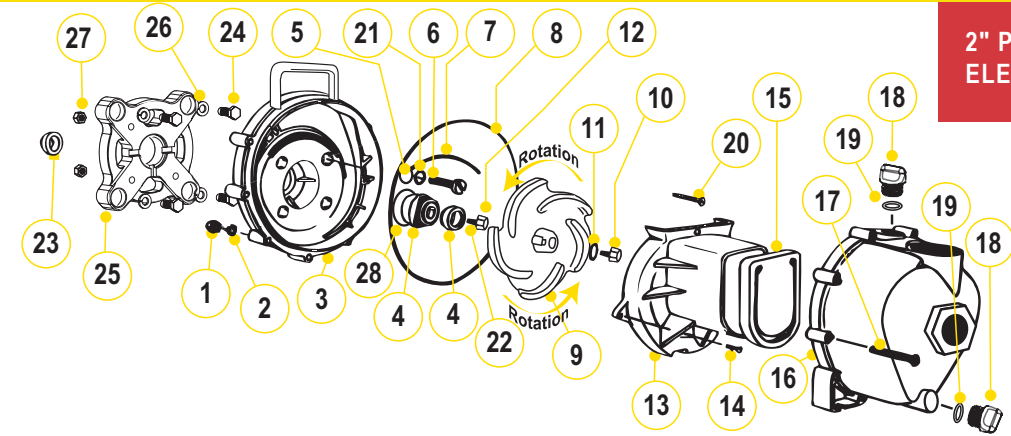

## 2" POLY PUMPS WITH ELECTRIC MOTORS

### REPLACEMENT PARTS 2" POLY PUMPS

| ITEM | PART NO     | DESCRIPTION                       | QTY |
|------|-------------|-----------------------------------|-----|
| 1    | V07019      | SS BODY NUTS                      | 10  |
| 2    | V07018      | SS LOCK WASHERS                   | 10  |
| 3    | 12703A      | POLY PUMP REAR BRACKET            | 1   |
| 4    | 12713       | SEAL ASSEMBLY EPDM                | 1   |
| 4    | 12713V      | SEAL ASSEMBLY FKM                 | 1   |
| 5    | 12717       | SCREW HEADS O-RING EPDM           | 4   |
| 5    | 12717V      | SCREW HEADS O-RING FKM            | 4   |
| 6    | N/A         | SS BRACKET SCREWS                 | 4   |
| 7    | 12754       | O-RING SEGMENT EPDM               | 1   |
| 7    | 12754V      | O-RING SEGMENT FKM                | 1   |
| 8    | 12719A      | BODY O-RING EPDM                  | 1   |
| 8    | 12719AV     | BODY O-RING FKM                   | 1   |
| 9    | 12772       | 5 VANE IMPELLER                   | 1   |
| 10   | 12765A      | SS IMPELLER BOLT                  | 1   |
| 11   | A204        | O-RING                            | 1   |
| 11   | A204V       | FKM O-RING                        | 1   |
| 12   | 12775A      | IMPELLER HEX NUT                  | 1   |
| 13   | 12702A      | POLY PUMP VOLUTE                  | 1   |
| 14   | 12725       | SS VOLUTE SCREWS                  | 2   |
| 15   | 12705       | POLY PUMP CHECK VALVE EPDM        | 1   |
| 15   | 12705V      | POLY PUMP CHECK VALVE FKM         | 1   |
| 16   | 12712A      | BODY ASSEMBLY EPDM                | 1   |
| 16   | N/A         | BODY ASSEMBLY FKM                 | 1   |
| 17   | 12720       | SS BODY SCREWS                    | 10  |
| 18   | 12777       | 1/2" PLUG                         | 2   |
| 19   | UV15163     | PRIME/DRAIN PLUG O-RING           | 2   |
| 19   | UV15163V    | FKM PRIME/DRAIN PLUG O-RING       | 2   |
| 20   | 12900       | SS UPPER VOLUTE SCREW             | 1   |
| 21   | 12901       | SS REAR BRACKET WASHER            | 4   |
| 22   | 12902A      | IMPELLER KEY                      | 1   |
| 23   | 12716       | PUMP SLINGER                      | 1   |
| 24   | 17704       | 3/8"-16 X 1.25" HHCS              | 8   |
| 25   | 12046       | 56C FRAME ADAPTER                 | 1   |
| 26   | V20018      | LOCK WASHER FOR 56C FRAME ADAPTER | 8   |
| 27   | V10119      | NUT FOR 56C FRAME ADAPTER         | 4   |
| 28   | 12710       | O-RING FOR SEAL ASSEMBLY          | 1   |
| 28   | 12710V      | FKM O-RING FOR SEAL ASSEMBLY      | 1   |
| NS   | BEM5-182CZ  | 5 HP, 182CZ, 3 PH                 | 1   |
| NS   | BEM51-182CZ | 5 HP, 182CZ, 1 PH                 | 1   |

### REPLACEMENT PARTS 2" POLY PUMPS

| ITEM | PART NO | DESCRIPTION  | QTY |
|------|---------|--|-----|
| N/S  | 17701   | BASE PLATE   | 1   |
| N/S  | 12099   | 7/16"-14 X 1.25" HHCS  | 1   |
| N/S  | 12052   | 56C FRAME ADAPTER SHAFT FOR 200PEO   | 1   |
| KIT  | 12756   | 56C FRAME ADAPTER KIT (ITEMS 6, 22, 24-27, 12052, 12053, 15751, 15752)     | 1   |
| KIT  | 12000A  | POLY PUMP EPDM REPAIR KIT (ITEMS 4, 5, 7, 8, 9, 11, 15, 19, 22-23 & 12099) | 1   |
| KIT  | 12000AV | POLY PUMP FKM REPAIR KIT (ITEMS 4, 5, 7, 8, 9, 11, 15, 19, 22-23 & 12099)  | 1   |
| KIT  | 12999A  | PUMP SEAL/O-RING KIT (ITEMS 4, 5, 7, 8, 11, 19, 23)                        | 1   |
| KIT  | 12999AV | FKM PUMP SEAL/O-RING KIT (ITEMS 4, 5, 7, 8, 11, 19, 23)                    | 1   |

### KITS 2" POLY PUMPS

| PART NO   | REPAIR KIT NO | SEAL KIT NO | FRAME ADAPTER KIT |
|-----------|---------------|-------------|-------------------|
| 234PPE5   | 12000A        | 12999A      | 12756             |
| 234PPE5V  | 12000AV       | 12999AV     | 12756             |
| 234PPE51  | 12000A        | 12999A      | 12756             |
| 234PPE51V | 12000AV       | 12999AV     | 12756             |

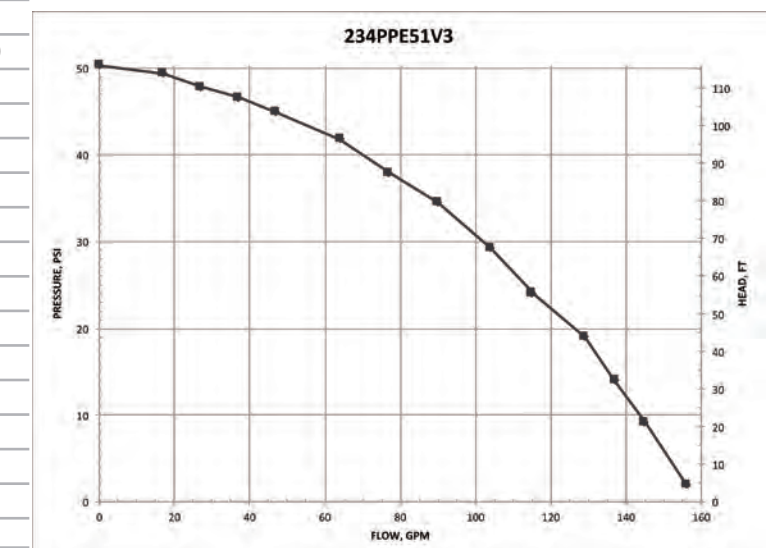



## 2" POLY PUMPS WITH HYDRAULIC MOTORS

### FEATURES

- Precision molded construction
- Lightweight
- Corrosion resistant
- Low maintenance
- Hydraulic fluid capacity is minimum 6 gallons and maximum 10 gallons
- Open or closed system
- 3600 R.P.M.
- Recommendation to use the motor spool control valve or a suitable equivalent. The lack of such a valve in this circuit may cause failure to the hydraulic motor and will void warranty.



### 2" POLY PUMPS W/HYDRAULIC MOTORS

| PART NO | DESCRIPTION                                   | HP   | QTY | SKID QTY |
|---------|---|------|-----|----------|
| 200PHA  | 2" POLY PUMP WITHOUT HYDRAULIC MOTOR          | N/A  | 1   | 27       |
| 200PHY  | 2" POLY PUMP W/12 HP HYDRAULIC MOTOR          | 12.0 | 1   | 18       |
| 200PHYW | 2" POLY WET SEAL PUMP W/12 HP HYDRAULIC MOTOR | 12.0 | 1   | 18       |



**WARNING! DO NOT RUN PUMP DRY, RESTRICT OR REDUCE PORT SIZES OR DEAD HEAD PUMP**



**WARNING! DO NOT USE WITH FLAMMABLE LIQUIDS**

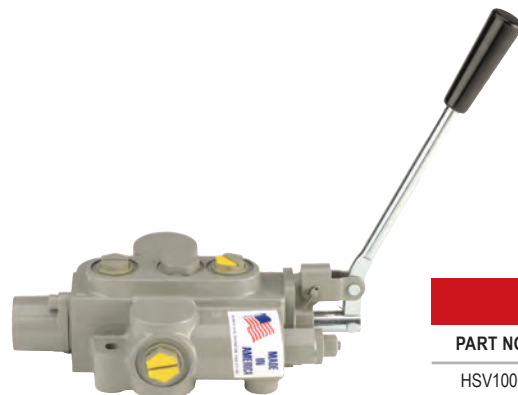
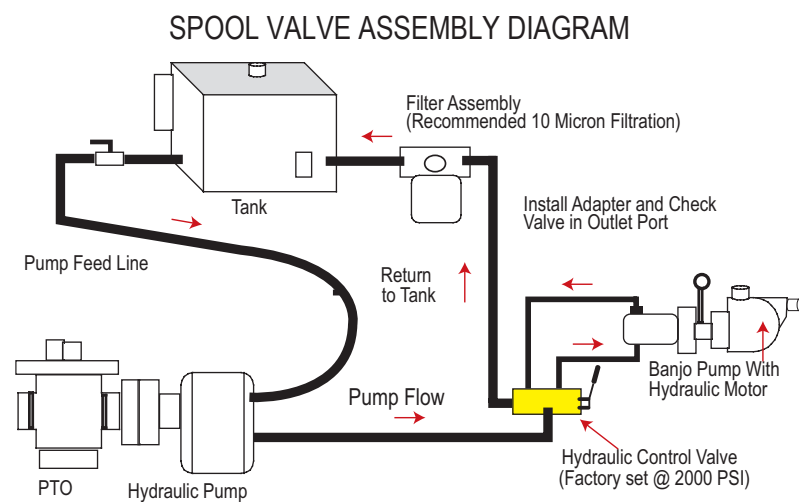

### HYDRAULIC MOTOR SPOOL VALVE

| PART NO | DESCRIPTION                 | HP  | QTY |
|---------|-----------------------------|-----|-----|
| HSV1000 | HYDRAULIC MOTOR SPOOL VALVE | N/A | 1   |

## 2" POLY PUMPS WITH HYDRAULIC MOTORS

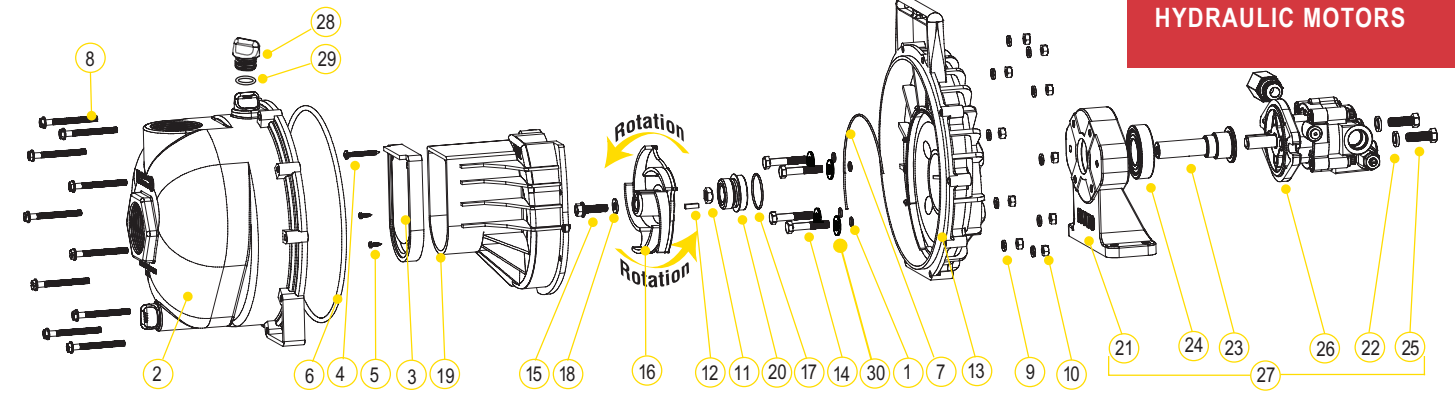

### REPLACEMENT PARTS 2" POLY PUMPS

| ITEM | PART NO | DESCRIPTION  | QTY |
|------|---------|--|-----|
| 1    | 12717   | O-RING FOR SCREW HEADS   | 4   |
| 2    | 12712A  | BODY ASSEMBLY  | 1   |
| 3    | 12705   | CHECK VALVE  | 1   |
| 4    | 12900   | SS UPPER VOLUTE SCREW  | 1   |
| 5    | 12725   | SS VOLUTE SCREWS   | 2   |
| 6    | 12719A  | BODY O-RING  | 1   |
| 7    | 12754   | O-RING SEGMENT   | 1   |
| 8    | 12720   | SS BODY SCREWS   | 10  |
| 9    | V07018  | SS LOCK WASHERS  | 10  |
| 10   | V07019  | SS BODY NUTS   | 10  |
| 11   | 12775A  | IMPELLER HEX NUT   | 1   |
| 12   | 12902A  | IMPELLER KEY   | 1   |
| 13   | 12703A  | POLY PUMP REAR BRACKET   | 1   |
| 14   | 12715A  | 5/16"-24 X 1.75" HHCS  | 4   |
| 15   | 12765A  | SS IMPELLER BOLT   | 1   |
| 16   | 12772   | 5 VANE IMPELLER  | 1   |
| 17   | 12710   | O-RING FOR SEAL ASSEMBLY   | 1   |
| 18   | A204    | O-RING   | 1   |
| 19   | 12702A  | POLY PUMP VOLUTE   | 1   |
| 20   | 12713   | MECHANICAL SEAL ASSEMBLY   | 1   |
| 21   | 12049F  | HYDRAULIC PEDESTAL HOUSING   | 1   |
| 22   | V20018  | 3/8" LOCK WASHER   | 2   |
| 23   | 12055E  | ADAPTER SHAFT  | 1   |
| 24   | 17056E  | BEARING  | 1   |
| 25   | 18010SS | 3/8"-16 X 1.25" HHCS   | 2   |
| 26   | HY1013  | HYDRAULIC MOTOR  | 1   |
| 27   | 12600B  | COMPLETE HYDRAULIC ASSEMBLY  | 1   |
| 28   | 12777   | 1/2" PLUG  | 2   |
| 29   | UV15163 | O-RING FOR PLUG  | 2   |
| 30   | 12901   | WASHER (200PHA & 200PHY)   | 4   |
| N/S  | HY1003  | HYDRAULIC MOTOR SEAL KIT   | 1   |
| KIT  | 12000A  | POLY PUMP EPDM REPAIR KIT (ITEMS 1, 3, 6, 7, 12, 16-18, 20, 12099) | 1   |
| KIT  | 12999A  | PUMP SEAL/O-RING KIT (ITEMS 1, 6, 7, 17, 20, 29, 12099)            | 1   |

### KITS 2" POLY PUMPS

| PART NO | EPDM REPAIR KIT NO | EPDM SEAL KIT NO | HYDRAULIC MOTOR SEAL KIT |
|---------|--------------------|------------------|--------------------------|
| 200PHA  | 12000A             | 12999A           | N/A                      |
| 200PHY  | 12000A             | 12999A           | HY1003                   |

### HYDRAULIC MOTOR DATA

|                        |                        |
|------------------------|------------------------|
| U.S. GALLONS/REV.      | 0.0025                 |
| CUBIC INCHES/REV.      | 0.580                  |
| LITERS/REV.            | 0.0097                 |
| MAX HYDRAULIC PRESSURE | 2000 PSI               |
| MIN HYDRAULIC PRESSURE | 200 PSI                |
| INLET PORT             | SAE 10 (7/8-14 UNF-2B) |
| OUTLET PORT            | SAE 10 (7/8-14 UNF-2B) |
| MINIMUM GPM REQUIRED   | 6 GPM 2400 RPM         |
| MAXIMUM GPM REQUIRED   | 10 GPM 4000 RPM        |
| IDEAL GPM REQUIRED     | 9 GPM 3600 RPM         |

### CONNECTION INFORMATION

|        |          |
|--------|----------|
| INLET  | "A" PORT |
| OUTLET | "B" PORT |

SUPPLIED CHECK VALVE IS TO ENSURE PROPER ROTATION OF THE BANJO PUMP. PLACE CHECK VALVE IN OUTLET PORT (MARKED "B") FOR PROPER RIGHT HAND ROTATION.

### SPOOL VALVE INFORMATION

|                          |                            |
|--------------------------|----------------------------|
| REQUIRED OUTLET FLOW     | MIN 6 GPM / MAX 10 GPM     |
| REQUIRED SYSTEM PRESSURE | MIN 600 PSI / MAX 3000 PSI |

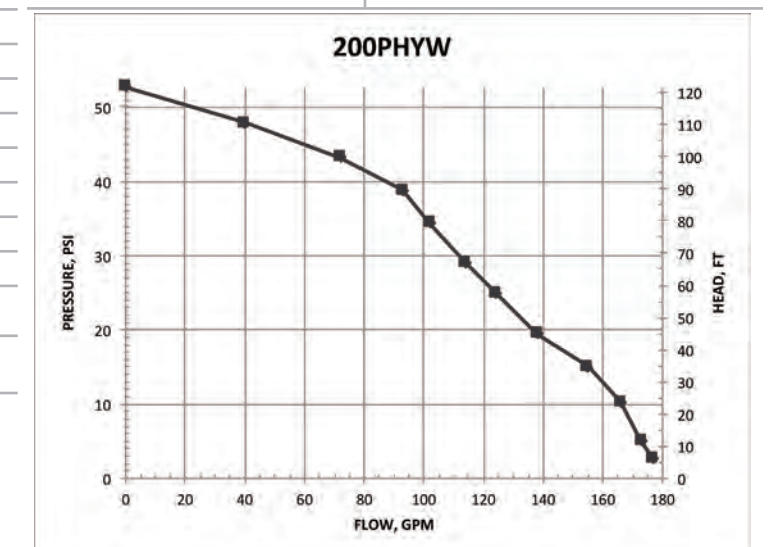

## 2" POLY MANIFOLD PUMPS WITH GAS ENGINES

## 2" POLY MANIFOLD PUMPS WITH GAS ENGINES

### FEATURES

- Precision molded construction
- Lightweight
- Corrosion resistant
- Low maintenance
- See pages 43-49 on manifold fittings for easy plumbing.



### 2" POLY MANIFOLD PUMPS W/GAS ENGINES

| PART NO   | DESCRIPTION   | HP  | QTY | SKID QTY |
|-----------|---|-----|-----|----------|
| M220PH5   | 2" POLY MANIFOLD PUMP W/5.5 HP HONDA® ENGINE                      | 5.5 | 1   | 12       |
| M220PH6   | 2" FP MANIFOLD PUMP W/6.5 HP HONDA® ENGINE                        | 6.5 | 1   | 12       |
| M220P6PRO | 2" FP MANIFOLD PUMP W/6.5 HP BRIGGS & STRATTON® PRO SERIES ENGINE | 6.5 | 1   | 12       |

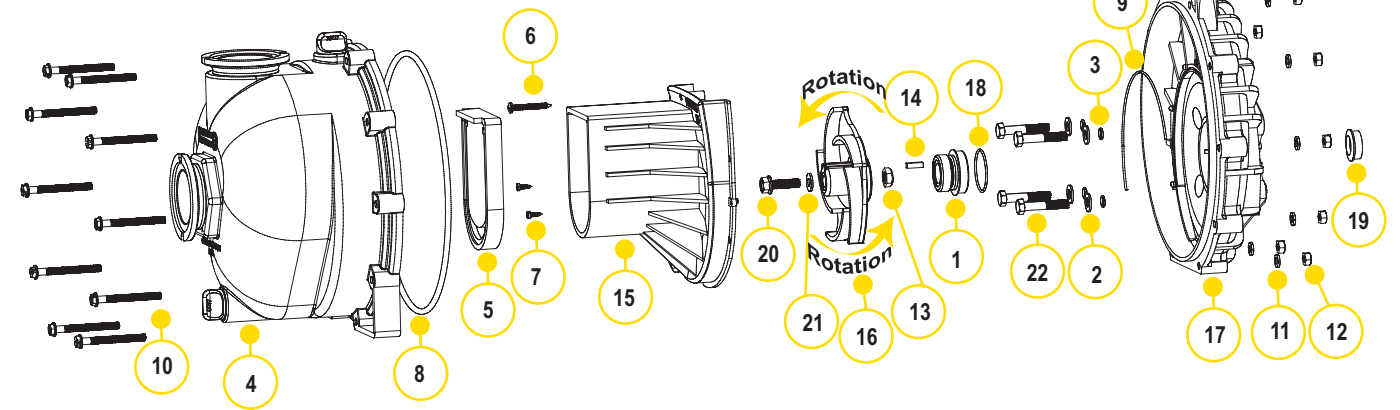

### REPLACEMENT PARTS 2" POLY PUMPS

| ITEM | PART NO | DESCRIPTION  | QTY |
|------|---------|--|-----|
| 1    | 12713   | MECHANICAL SEAL ASSEMBLY   | 1   |
| 2    | 12901   | SS REAR BRACKET WASHER   | 4   |
| 3    | 12717   | O-RING FOR SCREW HEAD  | 4   |
| 4    | M12712  | 2" FP MANIFOLD PUMP BODY ASSEMBLY                                | 1   |
| 5    | 12705   | POLY PUMP CHECK VALVE  | 1   |
| 6    | 12900   | SS UPPER VOLUTE SCREW  | 1   |
| 7    | 12725   | SS VOLUTE SCREWS   | 2   |
| 8    | 12719A  | BODY O-RING  | 1   |
| 9    | 12754   | O-RING SEGMENT   | 1   |
| 10   | 12720   | SS BODY SCREWS   | 10  |
| 11   | V07018  | SS LOCK WASHERS  | 10  |
| 12   | V07019  | SS BODY NUTS   | 10  |
| 13   | 12775A  | IMPELLER HEX NUT   | 1   |
| 14   | 12902A  | IMPELLER KEY   | 1   |
| 15   | 12702A  | POLY PUMP VOLUTE   | 1   |
| 16   | 12772   | 5 VANE IMPELLER  | 1   |
| 16   | 12771A  | 3 VANE IMPELLER  | 1   |
| 17   | 12703A  | POLY PUMP REAR BRACKET   | 1   |
| 18   | 12710   | O-RING FOR SEAL ASSEMBLY   | 1   |
| 19   | 12716   | POLY PUMP SLINGER  | 1   |
| 20   | 12765A  | SS IMPELLER BOLT   | 1   |
| 21   | A204    | O-RING   | 1   |
| 22   | 12715A  | SS BRACKET SCREWS  | 4   |
| KIT  | 12000A  | POLY PUMP EPDM REPAIR KIT (ITEMS 2,4,7,8,14, 17,19,21,30, 12099) | 1   |
| KIT  | 12000AV | POLY PUMP FKM REPAIR KIT (ITEMS 2,4,7,8,14, 17,19,21,30, 12099)  | 1   |
| KIT  | 12999A  | PUMP SEAL/O-RING KIT (ITEMS 2,4,7,8,17,19,21,30, 12099)          | 1   |
| KIT  | 12999AV | FKM PUMP SEAL/O-RING KIT (ITEMS 4-7,8,10,18, 23 & 12099)         | 1   |

### KITS 2" POLY PUMPS

| PART NO   | EPDM REPAIR KIT NO | FKM REPAIR KIT NO | EPDM SEAL KIT NO | FKM SEAL KIT NO |
|-----------|--------------------|-------------------|------------------|-----------------|
| M220PH5   | 12000A             | 12000AV           | 12999A           | 12999AV         |
| M220PH6   | 12000A             | 12000AV           | 12999A           | 12999AV         |
| M220P6PRO | 12000A             | 12000AV           | 12999A           | 12999AV         |
| M225PO    | 12000A             | 12000AV           | 12999A           | 12999AV         |

SEE 12000A & 12000AV KIT DRAWING ON PAGE 101



WARNING! DO NOT RUN PUMP DRY, RESTRICT OR REDUCE PORT SIZES OR DEAD HEAD PUMP



WARNING! DO NOT USE WITH FLAMMABLE LIQUIDS



### 2" POLY MANIFOLD PUMP ONLY

| PART NO | DESCRIPTION  | HP  | QTY | SKID QTY |
|---------|--|-----|-----|----------|
| M225PO  | 2" POLY MANIFOLD PUMP ONLY W/ 3/4" SHAFT & 5 VANE IMPELLER | N/A | 1   | 27       |

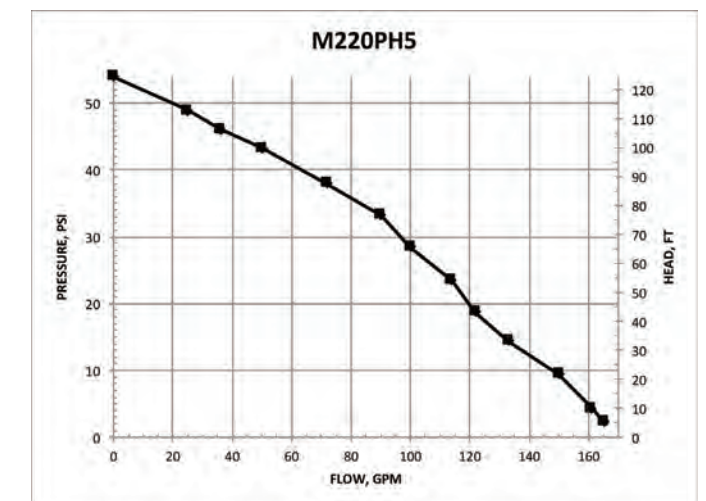



## 2" POLY MANIFOLD WET SEAL PUMPS

## 2" POLY MANIFOLD WET SEAL PUMPS

### FEATURES

- Run dry capability
- Double seal contained in ethylene glycol reservoir. Carbon ceramic seal faces with stainless steel cup and spring with EPDM rubber
- Pump end separated from engine
- Large weep holes between pump and engine
- V-shaped for quicker priming
- See pages 43-49 on manifold fittings for easy plumbing.

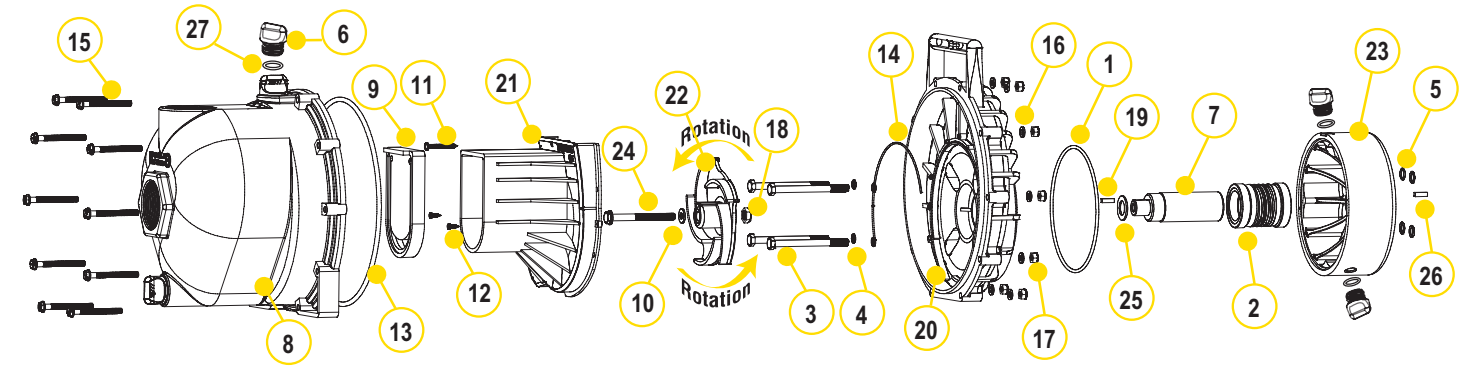

| 2" POLY MANIFOLD WET SEAL PUMPS W/GAS ENGINES |   |     |     |          |
|---|---|-----|-----|----------|
| PART NO                                       | DESCRIPTION   | HP  | QTY | SKID QTY |
| M220PH5W                                      | 2" POLY MANIFOLD WET SEAL PUMP W/5.5 HP HONDA® ENGINE | 5.5 | 1   | 12       |

### REPLACEMENT PARTS 2" POLY PUMPS

| ITEM | PART NO | DESCRIPTION                       | QTY |
|------|---------|-----------------------------------|-----|
| 1    | 13719   | O-RING                            | 1   |
| 2    | 15035E  | EPDM MECHANICAL SEAL ASSEMBLY     | 1   |
| 3    | 13034   | 5/16" -24 X 3 3/4" HHCS           | 4   |
| 4    | 12717   | O-RING FOR BRACKET SCREW          | 4   |
| 5    | 12709   | O-RING                            | 4   |
| 6    | 12777   | 1/2" PLUG                         | 4   |
| 7    | 12155   | ADAPTER SHAFT                     | 1   |
| 8    | M12712  | 2" FP MANIFOLD PUMP BODY ASSEMBLY | 1   |
| 9    | 12705   | CHECK VALVE                       | 1   |
| 10   | A204    | IMPELLER BOLT GASKET              | 1   |
| 11   | 12900   | #10 X 1 1/2" PPH SMS              | 1   |
| 12   | 12725   | #6 X 1/2" PPH SMS                 | 2   |
| 13   | 12719A  | BODY O-RING                       | 1   |
| 14   | 12754   | O-RING SEGMENT                    | 1   |
| 15   | 12720   | 1/4" - 20 X 2 1/2" SL IND HWHS    | 10  |
| 16   | V07018  | 1/4" LOCK WASHER                  | 10  |
| 17   | V07019  | 1/4" - 20 HEX NUT                 | 10  |
| 18   | 12775A  | 7/16" - 14 HEX NUT                | 1   |
| 19   | 12902A  | 3/16" SQ. X 5/8" KEY              | 2   |
| 20   | 12707W  | WET SEAL REAR BRACKET             | 1   |
| 21   | 12702A  | VOLUTE                            | 1   |
| 22   | 12772   | 5 VANE IMPELLER                   | 1   |
| 23   | 12202W  | WET SEAL RESERVOIR                | 1   |
| 24   | 12766   | 5/16" - 24 X 3 3/4" HFS           | 1   |
| 25   | CV10175 | GASKET                            | 1   |
| 26   | 12902A  | 1/4" SQ. 3/4" KEY STOCK           | 1   |
| 27   | UV15163 | O-RING FOR DRAIN PLUG             | 4   |



WARNING! DO NOT RUN PUMP DRY, RESTRICT OR REDUCE PORT SIZES OR DEAD HEAD PUMP



WARNING! DO NOT USE WITH FLAMMABLE LIQUIDS

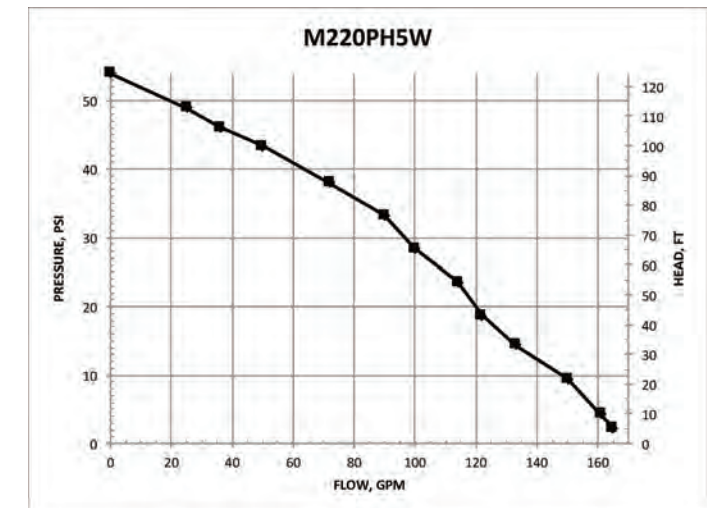

## 3" POLY PUMPS

## 3" POLY PUMPS

### FEATURES

- Large weep holes between pump and engine
- V-shaped for quicker priming
- Pump only comes unassembled



| 3" POLY PUMPS W/GAS ENGINES |  |     |     |      |     |
|-----------------------------|--|-----|-----|------|-----|
| PART NO                     | DESCRIPTION  | HP  | QTY | SKID | QTY |
| 300PH-6                     | 3" POLY PUMP W/6.5 HP HONDA® ENGINE  | 6.5 | 1   | 16   |     |
| 300P11PRO                   | 3" POLY PUMP W/11 HP BRIGGS & STRATTON® ENGINE PRO SERIES W/ELECTRIC START & PULL ROPE | 11  | 1   | 8    |     |

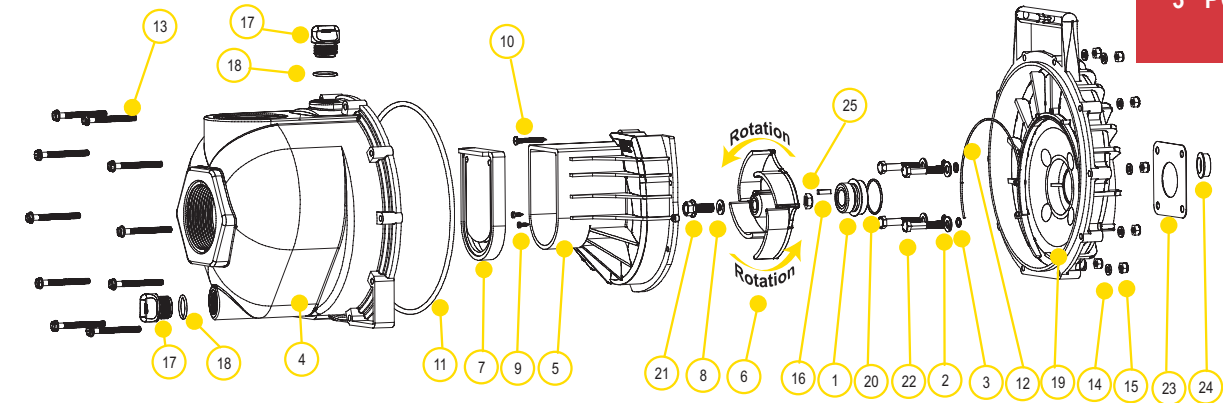

| REPLACEMENT PARTS 3" POLY PUMPS |         |   |     |
|---------------------------------|---------|---|-----|
| ITEM                            | PART NO | DESCRIPTION   | QTY |
| 1                               | 12713   | SEAL ASSEMBLY   | 1   |
| 2                               | 12901   | SS REAR BRACKET WASHER  | 1   |
| 3                               | 12717   | O-RING FOR SCREW HEAD   | 1   |
| 4                               | 13712   | BODY ASSEMBLY   | 1   |
| 5                               | 13702   | POLY PUMP VOLUTE  | 1   |
| 6                               | 13771   | 4 VANE TRIMMED IMPELLER (300PH-6, 300PB & 300PO)                            | 1   |
| 6                               | 13772   | 4 VANE IMPELLER (300P11PRO)   | 1   |
| 7                               | 12705   | CHECK VALVE   | 1   |
| 8                               | A204    | O-RING  | 1   |
| 9                               | 12900   | SS UPPER VOLUTE SCREW   | 1   |
| 10                              | 12725   | SS VOLUTE SCREWS  | 1   |
| 11                              | 12719A  | BODY O-RING   | 1   |
| 12                              | 12754   | O-RING SEGMENT  | 1   |
| 13                              | 12720   | SS BODY SCREWS  | 1   |
| 14                              | V07018  | SS LOCK WASHERS   | 1   |
| 15                              | V07019  | SS BODY NUTS  | 1   |
| 16                              | 12902A  | IMPELLER KEY  | 1   |
| 17                              | 13777   | ¾" PLUG   | 1   |
| 18                              | 13778   | O-RING  | 1   |
| 19                              | 12703A  | POLY PUMP REAR BRACKET  | 1   |
| 20                              | 12710   | O-RING FOR SEAL ASSEMBLY  | 1   |
| 21                              | 12765A  | SS IMPELLER BOLT 5/16 X 24 X 1.12 (300PH-6)                                 | 1   |
| 21                              | 13765   | SS IMPELLER BOLT 3/8 X 24 X 1.75 (300P11PRO)                                | 1   |
| 22                              | 12715A  | SS BRACKET SCREWS   | 1   |
| 23                              | 15751   | REAR BRACKET SHIM   | 1   |
| 24                              | 12716   | POLY PUMP SLINGER   | 1   |
| 25                              | 12775A  | IMPELLER HEX NUT  | 1   |
| N/S                             | 12882A  | BEARING PEDESTAL  | 1   |
| N/S                             | 12099   | 7/16"-14 X 1.25" HHCS   | 1   |
| N/S                             | 12000A  | POLY PUMP EPDM REPAIR KIT (ITEMS 1, 3, 6-8, 11, 12, 16, 18, 20, 24 & 12099) | 1   |
| N/S                             | 13999   | PUMP SEAL/O-RING KIT (ITEMS 1, 3, 8, 11, 12, 18, 20, 24 & 12099)            | 1   |

| KITS 3" POLY PUMPS |                    |                  |
|--------------------|--------------------|------------------|
| PART NO            | EPDM REPAIR KIT NO | EPDM SEAL KIT NO |
| 300PH-6            | 12000A             | 13999            |
| 300P11PRO          | 12000A             | 13999            |
| 300PB              | 12000A             | 13999            |
| 300PO              | 12000A             | 13999            |

SEE 12000A KIT DRAWING ON PAGE 101



WARNING! DO NOT RUN PUMP DRY, RESTRICT OR REDUCE PORT SIZES OR DEAD HEAD PUMP



WARNING! DO NOT USE WITH FLAMMABLE LIQUIDS



| 3" POLY BEARING PEDESTAL |  |     |     |      |     |
|--------------------------|--|-----|-----|------|-----|
| PART NO                  | DESCRIPTION  | HP  | QTY | SKID | QTY |
| 300PB                    | 3" POLY BEARING PEDESTAL W/ ¾" SHAFT & 4 VANE IMPELLER | N/A | 1   | 18   |     |



| 3" POLY PUMP ONLY |   |     |     |      |     |
|-------------------|---|-----|-----|------|-----|
| PART NO           | DESCRIPTION                                     | HP  | QTY | SKID | QTY |
| 300PO             | 3" POLY PUMP ONLY W/ ¾" SHAFT & 4 VANE IMPELLER | N/A | 1   | 27   |     |

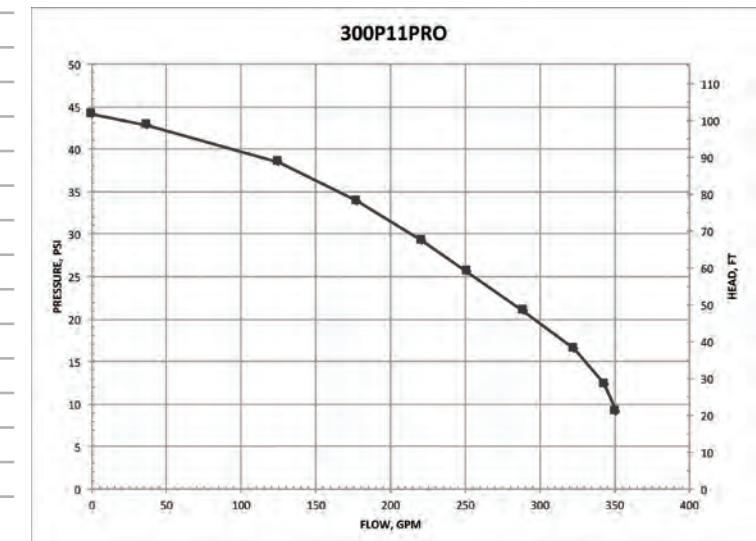



## 3" POLY MANIFOLD PUMPS

## 3" POLY MANIFOLD PUMPS

### FEATURES

- Large weep holes between pump and engine
- V-shaped for quicker priming
- Pump only comes unassembled
- See pages 43-49 on manifold fittings for easy plumbing.



| 3" POLY MANIFOLD PUMPS W/GAS ENGINES |  |     |     |          |
|--------------------------------------|--|-----|-----|----------|
| PART NO                              | DESCRIPTION  | HP  | QTY | SKID QTY |
| M300PH6                              | 3" POLY MANIFOLD PUMP W/6.5 HP HONDA® ENGINE   | 6.5 | 1   | 12       |
| M300P11PRO                           | 3" POLY MANIFOLD PUMP W/11 HP BRIGGS & STRATTON® PRO SERIES W/ELECTRIC START & PULL ROPE | 11  | 1   | 12       |

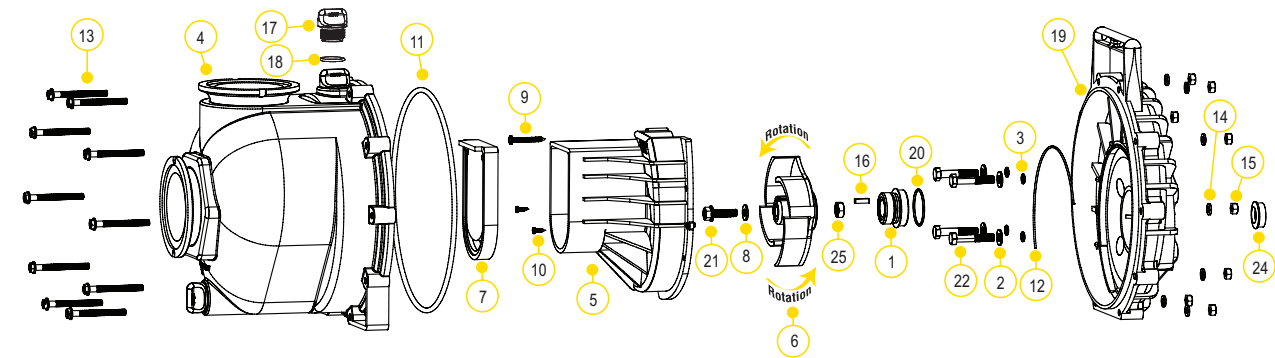

### REPLACEMENT PARTS 3" POLY MANIFOLD PUMPS

| ITEM | PART NO | DESCRIPTION   | QTY |
|------|---------|---|-----|
| 1    | 12713   | SEAL ASSEMBLY   | 1   |
| 2    | 12901   | SS REAR BRACKET WASHER  | 4   |
| 3    | 12717   | O-RING FOR SCREW HEAD   | 4   |
| 4    | M13712  | MANIFOLD BODY ASSEMBLY  | 1   |
| 5    | 13702   | POLY PUMP VOLUTE  | 1   |
| 6    | 13771   | 4 VANE TRIMMED IMPELLER (M300PH-6, M300PB & M300PO)                         | 1   |
| 6    | 13772   | 4 VANE IMPELLER (M300P11PRO)  | 1   |
| 7    | 12705   | CHECK VALVE   | 1   |
| 8    | A204    | O-RING  | 1   |
| 9    | 12900   | SS UPPER VOLUTE SCREW   | 4   |
| 10   | 12725   | SS VOLUTE SCREWS  | 2   |
| 11   | 12719A  | BODY O-RING   | 1   |
| 12   | 12754   | O-RING SEGMENT  | 1   |
| 13   | 12720   | SS BODY SCREWS  | 10  |
| 14   | V07018  | SS LOCK WASHERS   | 10  |
| 15   | V07019  | SS BODY NUTS  | 10  |
| 16   | 12902A  | IMPELLER KEY  | 1   |
| 17   | 13777   | 3/4" PLUG   | 2   |
| 18   | 13778   | O-RING  | 2   |
| 19   | 12703A  | POLY PUMP REAR BRACKET  | 1   |
| 20   | 12710   | O-RING FOR SEAL ASSEMBLY  | 1   |
| 21   | 12765A  | SS IMPELLER BOLT 5/16 X 24 X 1.12 (-6)                                      | 1   |
| 21   | 13765   | SS IMPELLER BOLT 3/8 X 24 X 1.75 (M300P11PRO)                               | 1   |
| 22   | 12715A  | SS BRACKET SCREWS   | 4   |
| 23   | 15751   | REAR BRACKET SHIM   | 1   |
| 24   | 12716   | POLY PUMP SLINGER   | 1   |
| 25   | 12775A  | IMPELLER HEX NUT  | 1   |
| N/S  | 12882A  | BEARING PEDESTAL  | 1   |
| N/S  | 12099   | 7/16"-14 X 1.25" HHCS   | 1   |
| N/S  | 12000A  | POLY PUMP EPDM REPAIR KIT (ITEMS 1, 3, 6-8, 11, 12, 16, 18, 20, 24 & 12099) | 1   |
| N/S  | 13999   | PUMP SEAL/O-RING KIT (ITEMS 1, 3, 8, 11, 12, 18, 20, 24 & 12099)            | 1   |

### KITS 3" POLY PUMPS

| PART NO    | EPDM REPAIR KIT NO | EPDM SEAL KIT NO |
|------------|--------------------|------------------|
| M300PH6    | 12000A             | 13999            |
| M300P11PRO | 12000A             | 13999            |
| M300PB     | 12000A             | 13999            |
| M300PO     | 12000A             | 13999            |



WARNING! DO NOT RUN PUMP DRY, RESTRICT OR REDUCE PORT SIZES OR DEAD HEAD PUMP



WARNING! DO NOT USE WITH FLAMMABLE LIQUIDS



| 3" POLY MANIFOLD BEARING PEDESTAL |   |     |     |          |
|-----------------------------------|---|-----|-----|----------|
| PART NO                           | DESCRIPTION   | HP  | QTY | SKID QTY |
| M300PB                            | 3" POLY MANIFOLD BEARING PEDESTAL W/ 3/4" SHAFT & 4 VANE IMPELLER | N/A | 1   | 18       |



| 3" POLY MANIFOLD PUMP ONLY |  |     |     |          |
|----------------------------|--|-----|-----|----------|
| PART NO                    | DESCRIPTION  | HP  | QTY | SKID QTY |
| M300PO                     | 3" POLY MANIFOLD PUMP ONLY W/ 3/4" SHAFT & 4 VANE IMPELLER | N/A | 1   | 27       |

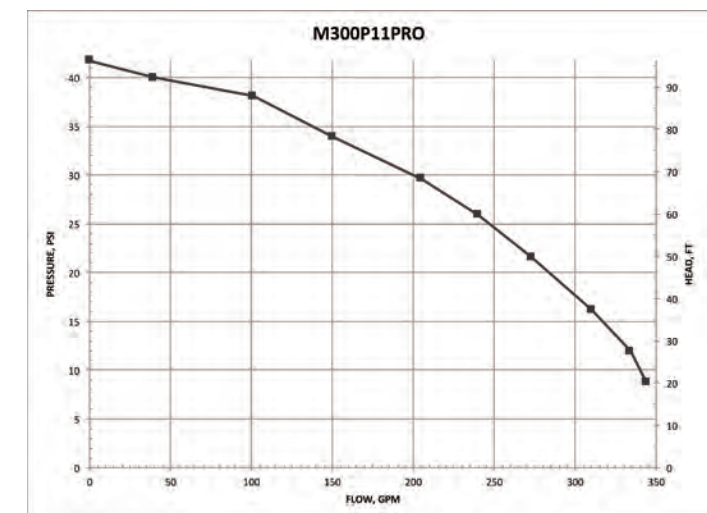

# CENTRIFUGAL PUMPS

## 3" POLY PUMPS WITH HYDRAULIC MOTORS

### FEATURES

- Precision molded construction
- Lightweight
- Corrosion resistant
- Low maintenance
- Hydraulic fluid capacity is minimum 6 gallons and maximum 10 gallons
- Open or closed system
- 3600 R.P.M.
- Recommendation to use the motor spool control valve or a suitable equivalent. The lack of such a valve in this circuit may cause failure to the hydraulic motor and will void warranty.



### 3" POLY PUMPS W/HYDRAULIC MOTORS

| PART NO | DESCRIPTION                                   | HP  | QTY | SKID QTY |
|---------|---|-----|-----|----------|
| 300PHY  | 3" POLY PUMP W/12 HP H HYDRAULIC MOTOR        | 12  | 1   | 18       |
| 300PHYW | 3" POLY WET SEAL PUMP W/12 HP HYDRAULIC MOTOR | 12  | 1   | 12       |
| 300PHA  | 3" POLY PUMP W/OUT HYDRAULICS                 | N/A | 1   | 27       |

### SPOOL VALVE ASSEMBLY DIAGRAM

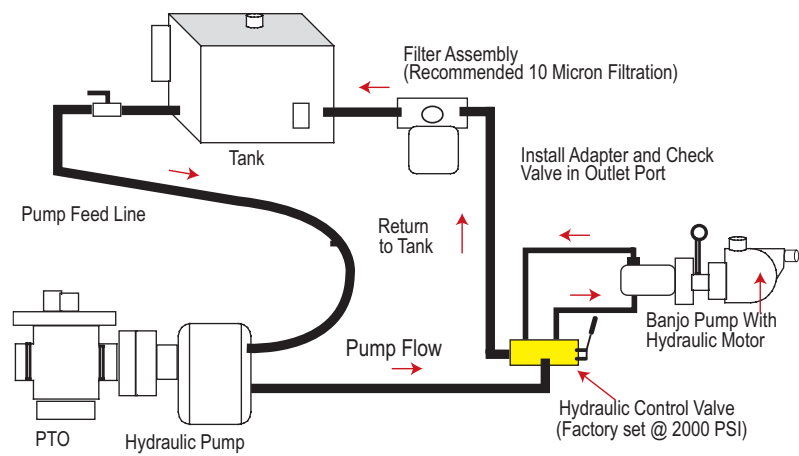

### HYDRAULIC MOTOR SPOOL VALVE

| PART NO | DESCRIPTION                 | HP  | QTY |
|---------|-----------------------------|-----|-----|
| HSV1000 | HYDRAULIC MOTOR SPOOL VALVE | N/A | 1   |

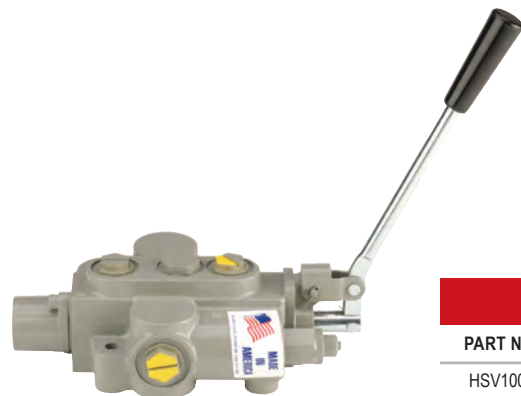

# CENTRIFUGAL PUMPS

## 3" POLY PUMPS WITH HYDRAULIC MOTORS

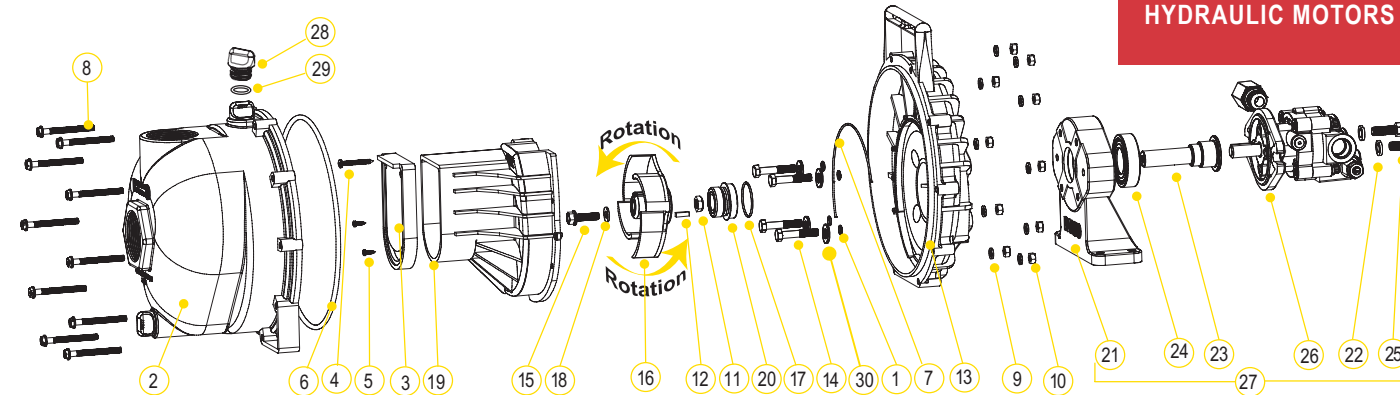

### REPLACEMENT PARTS 3" POLY PUMPS

| ITEM | PART NO | DESCRIPTION   | QTY |
|------|---------|---|-----|
| 1    | 12717   | O-RING FOR SCREW HEADS  | 4   |
| 2    | 13712   | BODY ASSEMBLY   | 1   |
| 3    | 12705   | CHECK VALVE   | 1   |
| 4    | 12900   | SS UPPER VOLUTE SCREW   | 4   |
| 5    | 12725   | SS VOLUTE SCREWS  | 2   |
| 6    | 12719A  | BODY O-RING   | 1   |
| 7    | 12754   | O-RING SEGMENT  | 1   |
| 8    | 12720   | SS BODY SCREWS  | 10  |
| 9    | V07018  | SS LOCK WASHERS   | 10  |
| 10   | V07019  | SS BODY NUTS  | 10  |
| 11   | 12775A  | IMPELLER HEX NUT  | 1   |
| 12   | 12902A  | IMPELLER KEY  | 1   |
| 13   | 12703A  | POLY PUMP REAR BRACKET  | 1   |
| 14   | 12715A  | 5/16"-24 X 1.75" HHCS   | 4   |
| 15   | 12765A  | SS IMPELLER BOLT  | 1   |
| 16   | 13772   | TRIMMED 4 VANE IMPELLER   | 1   |
| 17   | 12710   | O-RING FOR SEAL ASSEMBLY  | 1   |
| 18   | A204    | O-RING  | 1   |
| 19   | 13702   | POLY PUMP VOLUTE  | 1   |
| 20   | 12713   | MECHANICAL SEAL ASSEMBLY  | 1   |
| 21   | 12049F  | HYDRAULIC PEDESTAL HOUSING (MUST ORDER 17056E & 12055E)             | 1   |
| 22   | V20018  | 3/8" LOCK WASHER  | 2   |
| 23   | 12055E  | ADAPTER SHAFT   | 1   |
| 24   | 17056E  | BEARING   | 1   |
| 25   | 18010SS | 3/8" - 16 X 1 1/8" SS CAP SCREW HXHD                                | 2   |
| 26   | HY1013  | HYDRAULIC MOTOR   | 1   |
| 27   | 12600B  | COMPLETE HYDRAULIC ASSEMBLY   | 1   |
| 28   | 13777   | 3/4" PLUG   | 2   |
| 29   | 13778   | O-RING  | 2   |
| 30   | 12901   | SS REAR BRACKET WASHER (300PHY)                                     | 4   |
| N/S  | HY1003  | HYDRAULIC MOTOR SEAL KIT  | 1   |
| KIT  | 12000A  | POLY PUMP EPDM REPAIR KIT (ITEMS 1, 3, 6, 7, 16, 18, 20, 29, 12099) | 1   |
| KIT  | 13999   | PUMP SEAL/O-RING KIT (ITEMS 2,4,7-8,16,18,19, 21, 30, 12099)        | 1   |

### KITS 3" POLY PUMPS

| PART NO | EPDM REPAIR KIT NO | EPDM SEAL KIT NO | HYDRAULIC MOTOR SEAL KIT |
|---------|--------------------|------------------|--------------------------|
| 300PHY  | 12000A             | 13999            | HY1003                   |

### HYDRAULIC MOTOR DATA

|                        |                        |
|------------------------|------------------------|
| U.S. GALLONS/REV.      | 0.0025                 |
| CUBIC INCHES/REV.      | 0.580                  |
| LITERS/REV.            | 0.0097                 |
| MAX HYDRAULIC PRESSURE | 2000 PSI               |
| MIN HYDRAULIC PRESSURE | 200 PSI                |
| INLET PORT             | SAE 10 (7/8-14 UNF-2B) |
| OUTLET PORT            | SAE 10 (7/8-14 UNF-2B) |
| MINIMUM GPM REQUIRED   | 6 GPM 2400 RPM         |
| MAXIMUM GPM REQUIRED   | 10 GPM 4000 RPM        |
| IDEAL GPM REQUIRED     | 9 GPM 3600 RPM         |

### CONNECTION INFORMATION

|  |          |
|--|----------|
| INLET  | "A" PORT |
| OUTLET   | "B" PORT |
| SUPPLIED CHECK VALVE IS TO ENSURE PROPER ROTATION OF THE BANJO PUMP. PLACE CHECK VALVE IN OUTLET PORT (MARKED "B") FOR PROPER RIGHT HAND ROTATION. |          |

### SPOOL VALVE INFORMATION

|                          |                            |
|--------------------------|----------------------------|
| REQUIRED OUTLET FLOW     | MIN 6 GPM / MAX 10 GPM     |
| REQUIRED SYSTEM PRESSURE | MIN 600 PSI / MAX 3000 PSI |

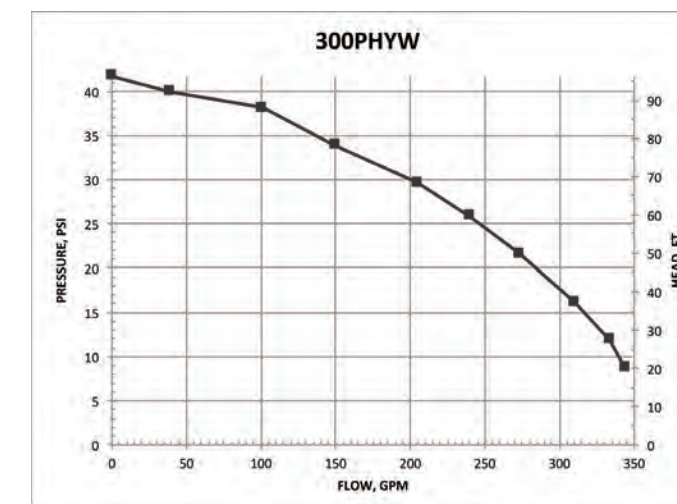

WARNING! DO NOT RUN PUMP DRY, RESTRICT OR REDUCE PORT SIZES OR DEAD HEAD PUMP



WARNING! DO NOT USE WITH FLAMMABLE LIQUIDS



## 3" POLY WET SEAL PUMPS

### FEATURES

- Run dry capability
- Double seal contained in ethylene glycol reservoir. Carbon ceramic seal faces with stainless steel cup and spring with EPDM rubber.
- V-shaped for quicker priming
- Engine warranty service available at authorized Briggs & Stratton® and Honda® dealers
- Due to weight and size of pumps, Banjo ships these by truck only.

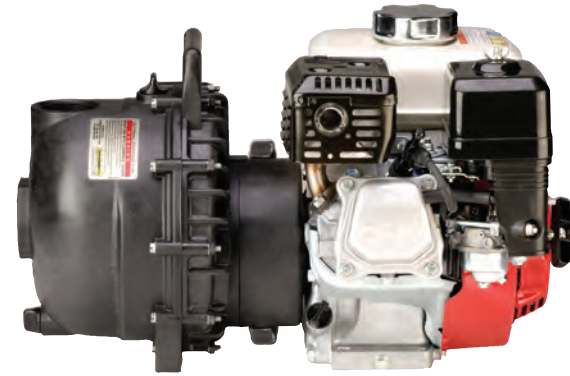

### 3" POLY WET SEAL PUMPS W/GAS ENGINES

| PART NO    | DESCRIPTION   | HP | QTY | SKID QTY |
|------------|---|----|-----|----------|
| 300PH6W    | 3" POLY WET SEAL PUMP W/6 HP HONDA® ENGINE  | 6  | 1   | 12       |
| 300P11PROV | 3" POLY WET SEAL PUMP W/11 HP BRIGGS & STRATTON® ENGINE PRO SERIES W/ELECTRIC START & PULL ROPE | 11 | 1   | 8        |
| 300PH13W   | 3" POLY WET SEAL PUMP W/13 HP HONDA® ENGINE W/ELECTRIC START & PULL ROPE                        | 13 | 1   | 8        |



### 3" POLY WET SEAL BEARING PEDESTAL

| PART NO | DESCRIPTION   | HP  | QTY | SKID QTY |
|---------|---|-----|-----|----------|
| 300PBW  | 3" POLY WET SEAL BEARING PEDESTAL W/ 3/4" SHAFT & 4 VANE IMPELLER | N/A | 1   | 27       |

### 3" POLY WET SEAL PUMP ONLY

| PART NO | DESCRIPTION                               | HP  | QTY | SKID QTY |
|---------|---|-----|-----|----------|
| 300POW  | 3" POLY WET SEAL PUMP ONLY FOR 1" SHAFT   | N/A | 1   | 27       |
| 300POW6 | 3" POLY WET SEAL PUMP ONLY FOR 3/4" SHAFT | N/A | 1   | 27       |



WARNING! DO NOT USE WITH FLAMMABLE LIQUIDS

## 3" POLY WET SEAL PUMPS

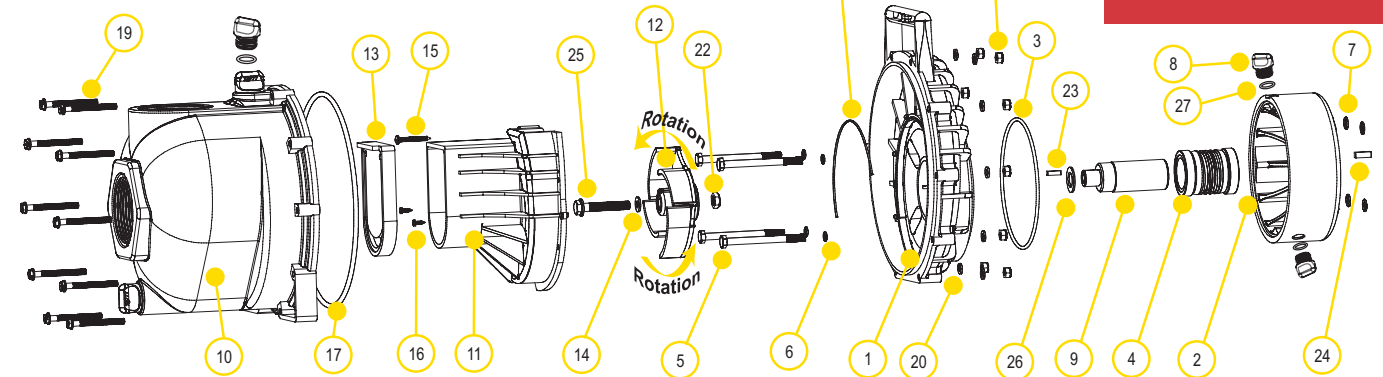

### REPLACEMENT PARTS 3" POLY PUMPS

| ITEM | PART NO | DESCRIPTION                            | QTY |
|------|---------|--|-----|
| 1    | 12703AW | WET SEAL REAR BRACKET                  | 1   |
| 2    | 12201W  | WET SEAL RESERVOIR                     | 1   |
| 2    | 12202W  | WET SEAL RESERVOIR (300POW6)           | 1   |
| 3    | 13719   | O-RING                                 | 1   |
| 3    | 13719V  | FKM O-RING (301POWV)                   | 1   |
| 4    | 15035E  | EPDM MECHANICAL SEAL ASSEMBLY          | 1   |
| 4    | 15035   | MECHANICAL SEAL ASSEMBLY (301POWV)     | 1   |
| 5    | 13034   | 5/16" -24 X 3 3/4" HHCS                | 4   |
| 6    | 12717   | O-RING FOR BRACKET SCREW               | 4   |
| 6    | 12717V  | FKM O-RING FOR BRACKET SCREW (301POWV) | 4   |
| 7    | 12709   | O-RING                                 | 4   |
| 7    | 12709V  | FKM O-RING (301POWV)                   | 4   |
| 8    | 12777   | 1/2" PLUG                              | 4   |
| 9    | 13055   | ADAPTER SHAFT (300PH6W & 300PH13W)     | 1   |
| 9    | N/A     | ADAPTER SHAFT (300P11PROV & 301POWV)   | 1   |
| 9    | 12155   | ADAPTER SHAFT (300PH6W)                | 1   |
| 10   | 13712   | BODY ASSEMBLY                          | 1   |
| 10   | 13712   | FKM BODY ASSEMBLY (301POWV)            | 1   |
| 11   | 13702   | VOLUTE                                 | 1   |
| 12   | 13772   | 4 VANE IMPELLER                        | 1   |
| 12   | 13771   | TRIMMED IMPELLER (300POW6)             | 1   |
| 13   | 12705   | CHECK VALVE                            | 1   |
| 13   | 12705V  | FKM CHECK VALVE (301POWV)              | 1   |
| 14   | A204    | IMPELLER BOLT GASKET                   | 1   |
| 14   | A204V   | FKM IMPELLER BOLT GASKET (301POWV)     | 1   |
| 15   | 12900   | #10 X 1 1/2" PPH SMS                   | 1   |
| 16   | 12725   | #6 X 1/2" PPH SMS                      | 2   |
| 17   | 13719   | BODY O-RING                            | 1   |
| 17   | 13719V  | FKM BODY O-RING (301POWV)              | 1   |
| 18   | 12754   | O-RING SEGMENT                         | 1   |
| 18   | 12754V  | FKM O-RING SEGMENT (301POWV)           | 1   |
| 19   | 12720   | 1/4" - 20 X 2 1/2" SL IND HWHS         | 10  |
| 20   | V07018  | 1/4" LOCK WASHER                       | 10  |
| 21   | V07019  | 1/4" - 20 HEX NUT                      | 10  |
| 22   | 12775A  | 7/16" - 14 HEX NUT                     | 1   |
| 23   | 12902A  | 3/16" SQ. X 5/8" KEY                   | 2   |
| 24   | 16901   | 1/4" SQUARE KEY                        | 1   |
| 25   | 13766   | 3/8-24 X 2 1/4" HFS                    | 1   |

### REPLACEMENT PARTS 3" POLY PUMPS

| ITEM | PART NO  | DESCRIPTION                         | QTY |
|------|----------|-------------------------------------|-----|
| 26   | CV10175  | GASKET                              | 1   |
| 26   | CV10175V | FKM GASKET (301POWV)                | 1   |
| 27   | UV15163  | O-RING FOR DRAIN PLUG               | 4   |
| 27   | UV15163V | FKM O-RING FOR DRAIN PLUG (301POWV) | 4   |

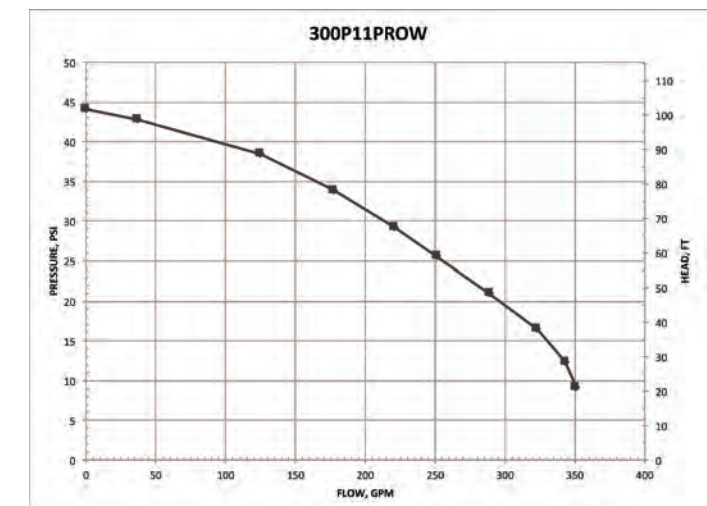

## 3" POLY MANIFOLD WET SEAL PUMPS

### FEATURES

- Run dry capability
- Double seal contained in ethylene glycol reservoir. Carbon ceramic seal faces with stainless steel cup and spring with EPDM rubber
- Pump end separated from engine
- V-shaped for quicker priming
- Engine warranty service available at authorized dealers
- See pages 43-49 on manifold fittings for easy plumbing.



### 3" POLY MANIFOLD WET SEAL PUMPS W/GAS ENGINES

| PART NO  | DESCRIPTION   | HP | QTY | SKID QTY |
|----------|---|----|-----|----------|
| M300PH6W | 3" POLY MANIFOLD WET SEAL PUMP W/6 HP HONDA® ENGINE | 6  | 1   | 12       |



### 3" POLY MANIFOLD WET SEAL PUMP ONLY

| PART NO  | DESCRIPTION  | HP  | QTY | SKID QTY |
|----------|--|-----|-----|----------|
| M300POW6 | 3" POLY MANIFOLD WET SEAL PUMP ONLY FOR 3/4" SHAFT | N/A | 1   | 27       |



### 3" POLY MANIFOLD WET SEAL PUMP W/HYDRAULIC

| PART NO  | DESCRIPTION                                      | HP  | QTY | SKID QTY |
|----------|--|-----|-----|----------|
| M305PHYW | 3" POLY MANIFOLD WET SEAL PUMP W/HYDRAULIC MOTOR | N/A | 1   | 12       |

## 3" POLY MANIFOLD WET SEAL PUMPS

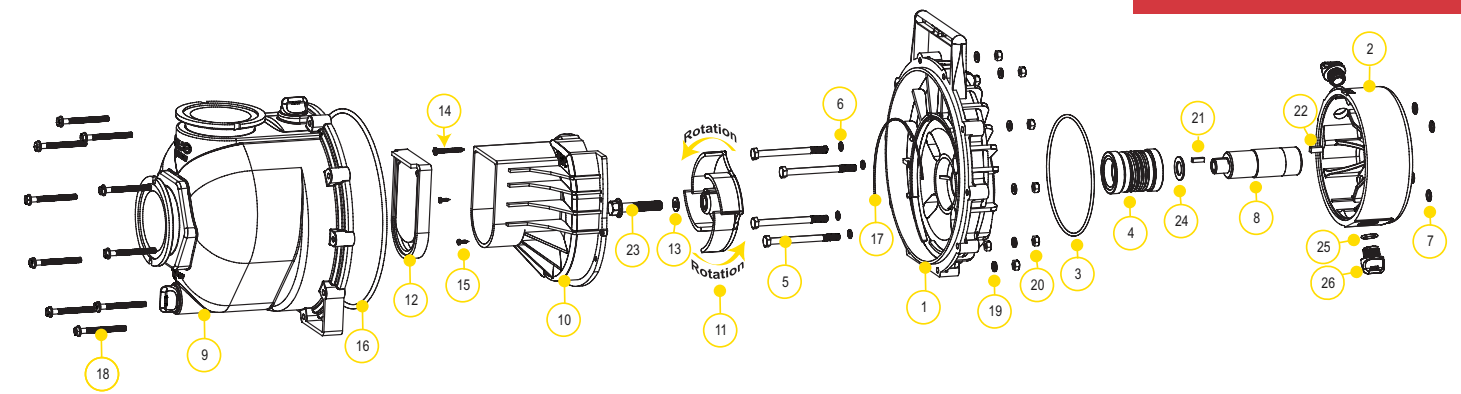

### REPLACEMENT PARTS 3" POLY PUMPS

| ITEM | PART NO | DESCRIPTION   | QTY |
|------|---------|---|-----|
| 1    | 12707W  | WET SEAL REAR BRACKET FOR 6 HP HONDA® ENGINE & BEARING PEDESTAL | 1   |
| 2    | 12202W  | WET SEAL RESERVOIR FOR 6 HP HONDA® ENGINE & BEARING PEDESTAL    | 1   |
| 3    | 13719   | O-RING  | 1   |
| 4    | 15035E  | MECHANICAL SEAL ASSEMBLY EPDM                                   | 1   |
| 5    | 13034   | 5/16" - 24 X 3 3/4" HHCS  | 4   |
| 6    | 12717   | O-RING FOR BRACKET SCREW  | 4   |
| 7    | 12709   | O-RING  | 4   |
| 8    | 12155   | ADAPTER SHAFT FOR 6 HP HONDA® ENGINE & BEARING PEDESTAL         | 1   |
| 9    | M13712  | MANIFOLD BODY ASSEMBLY  | 1   |
| 10   | 13702   | VOLUTE  | 1   |
| 11   | 13771   | 4 VANE IMPELLER   | 1   |
| 11   | 13772A  | 5 VANE IMPELLER (M305PHYW)                                      | 1   |
| 12   | 12705   | CHECK VALVE   | 1   |
| 13   | A204    | O-RING  | 1   |
| 14   | 12900   | #10 X 1 1/2" PPH SMS 18-8 SS                                    | 1   |
| 15   | 12725   | #6 X 1 1/2" PPH SMS 18-8 SS                                     | 1   |
| 16   | 12719A  | BODY O-RING   | 1   |
| 17   | 12754   | O-RING SEGMENT  | 1   |
| 18   | 12720   | 1/4" - 20 X 2 1/2" SL IND HWHS                                  | 10  |
| 19   | V07018  | 1/4" LOCK WASHER  | 10  |
| 20   | V07019  | 1/4" - 20 HEX NUT   | 10  |
| 21   | 12902A  | 3/16" SQ. X 3/8" KEY  | 1   |
| 22   | 16901   | 1/4" SQ. 3/4" KEY STOCK   | 1   |
| 23   | 12766   | 5/16"-24 X 3 3/4" HFS FOR 6 HP HONDA® ENGINE & BEARING PEDESTAL | 1   |
| 24   | CV10175 | GASKET  | 1   |
| 25   | UV15163 | O-RING  | 2   |
| 26   | 12777   | 1/2" PLUG   | 2   |

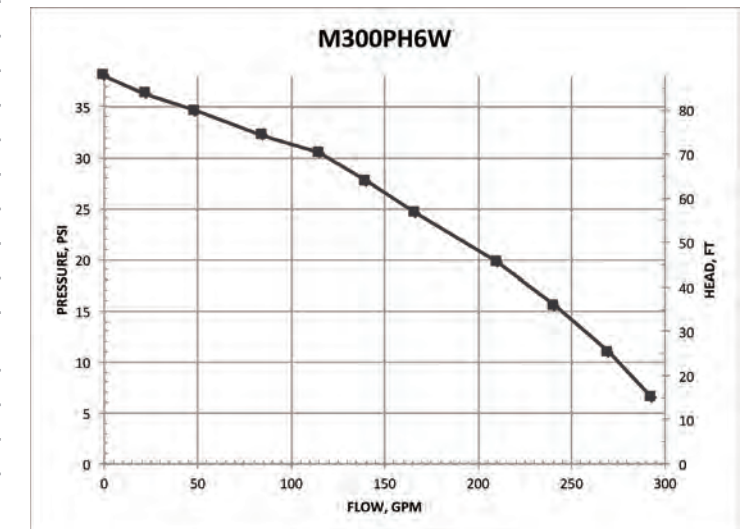

WARNING! DO NOT USE WITH FLAMMABLE LIQUIDS



# M350

**500+ GALLONS PER MINUTE  
NO LEAKS. NO WEAR. NO WORRIES  
PATENTED WET SEAL DESIGN  
ATTACHES EASILY**



## CENTRIFUGAL PUMPS

### 3" POLY M350 MANIFOLD WET SEAL PUMPS

#### FEATURES

- 500+ Gallons per Minute
- Polymer components molded from polypropylene
- EPDM seals
- All stainless steel hardware
- Tandem wet seal design
- Produces less wear
- Prevents seal breakage from high pressure clean out
- Eliminates eight leak points
- Works with natural system pressure to keep seal intact
- No exposed moving parts
- Typical operating speed: 3600 RPM
- Run dry capability of greater than one hour.
- Capable of handling occasional solid particles in suspension up to 1/2" in diameter.
- Maximum self-priming height 25 ft (7.6 m) for hydraulic version
- (0.422" priming hole); 28 ft (8.5 m) for standard version (0.250" priming hole)
- Engine warranty service available at authorized dealers
- See pages 43-49 on manifold fittings for easy plumbing.



**WARNING! DO NOT USE WITH FLAMMABLE LIQUIDS**

#### 3" POLY MANIFOLD WET SEAL PUMPS W/GAS ENGINES

| PART NO     | DESCRIPTION   | HP | QTY | SKID QTY |
|-------------|---|----|-----|----------|
| M350PVAN14W | 3" POLY MANIFOLD WET SEAL PUMP W/14 HP VANGUARD® ENGINE | 14 | 1   | 6        |



#### 3" POLY MANIFOLD WET SEAL PUMPS W/GAS ENGINES

| PART NO   | DESCRIPTION  | HP | QTY | SKID QTY |
|-----------|--|----|-----|----------|
| M350PH13W | 3" POLY MANIFOLD WET SEAL PUMP W/13 HP HONDA® ENGINE | 13 | 1   | 6        |



#### 3" POLY MANIFOLD WET SEAL PUMP W/ELECTRIC MOTOR

| PART NO   | DESCRIPTION   | HP  | QTY | SKID QTY |
|-----------|---|-----|-----|----------|
| M350PE15W | 3" POLY MANIFOLD WET SEAL PUMP W/15 HP 3 PHASE ELECTRIC MOTOR | N/A | 1   | 1        |



#### 3" POLY MANIFOLD WET SEAL PUMP ONLYS

| PART NO  | DESCRIPTION  | HP  | QTY | SKID QTY |
|----------|--|-----|-----|----------|
| M350POW  | 3" POLY MANIFOLD WET SEAL PUMP ONLY FOR 1" SHAFT GAS ENGINES | N/A | 1   | 27       |
| M350PEOW | 3" POLY MANIFOLD WET SEAL PUMP ONLY FOR ELECTRIC MOTOR       | N/A | 1   | 27       |



#### 3" POLY MANIFOLD WET SEAL PUMP W/HYDRAULIC

| PART NO  | DESCRIPTION                                      | HP  | QTY | SKID QTY |
|----------|--|-----|-----|----------|
| M350PHYW | 3" POLY MANIFOLD WET SEAL PUMP W/HYDRAULIC MOTOR | N/A | 1   | 12       |





# CENTRIFUGAL PUMPS

## 3" POLY M350 MANIFOLD WET SEAL PUMPS



| 3" POLY MANIFOLD WET SEAL PUMP W/HYDRAULIC |  |     |     |          |
|--|--|-----|-----|----------|
| PART NO                                    | DESCRIPTION  | HP  | QTY | SKID QTY |
| M350PHAW                                   | 3" POLY MANIFOLD WET SEAL PUMP W/HYDRAULIC PEDESTAL (NO MOTOR) | N/A | 1   | 12       |



| 3" POLY WET SEAL BEARING PEDESTAL |   |     |     |          |
|-----------------------------------|---|-----|-----|----------|
| PART NO                           | DESCRIPTION   | HP  | QTY | SKID QTY |
| M350PBW                           | 3" POLY WET SEAL BEARING PEDESTAL W/ 1" SHAFT & 4 VANE IMPELLER | N/A | 1   | 12       |



| 4" PLUMBING FITTINGS |                               |         |
|----------------------|-------------------------------|---------|
| PART NO              | DESCRIPTION                   | LOT QTY |
| M300400A             | 3" Manifold x 4" Male Coupler | 1       |
| M300400BRB           | 3" Manifold x 4" Hose Barb    | 1       |

OPTIMIZE FLOW WITH 4" SUCTION

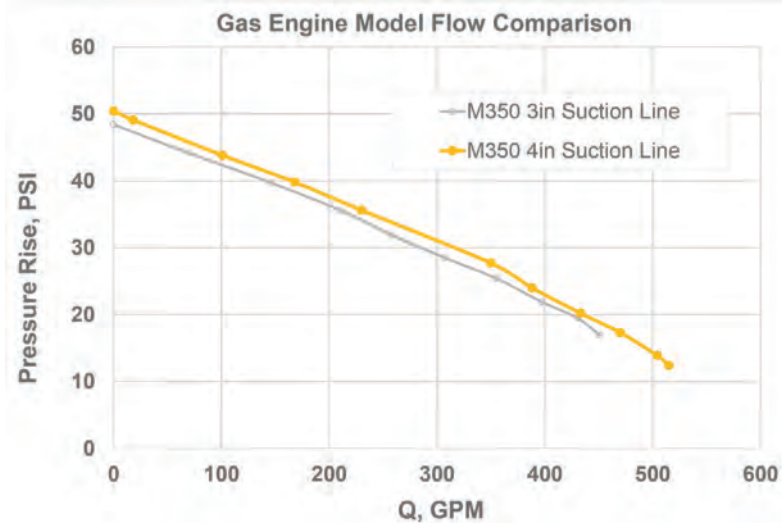

# CENTRIFUGAL PUMPS

## 3" POLY M350 MANIFOLD WET SEAL PUMPS

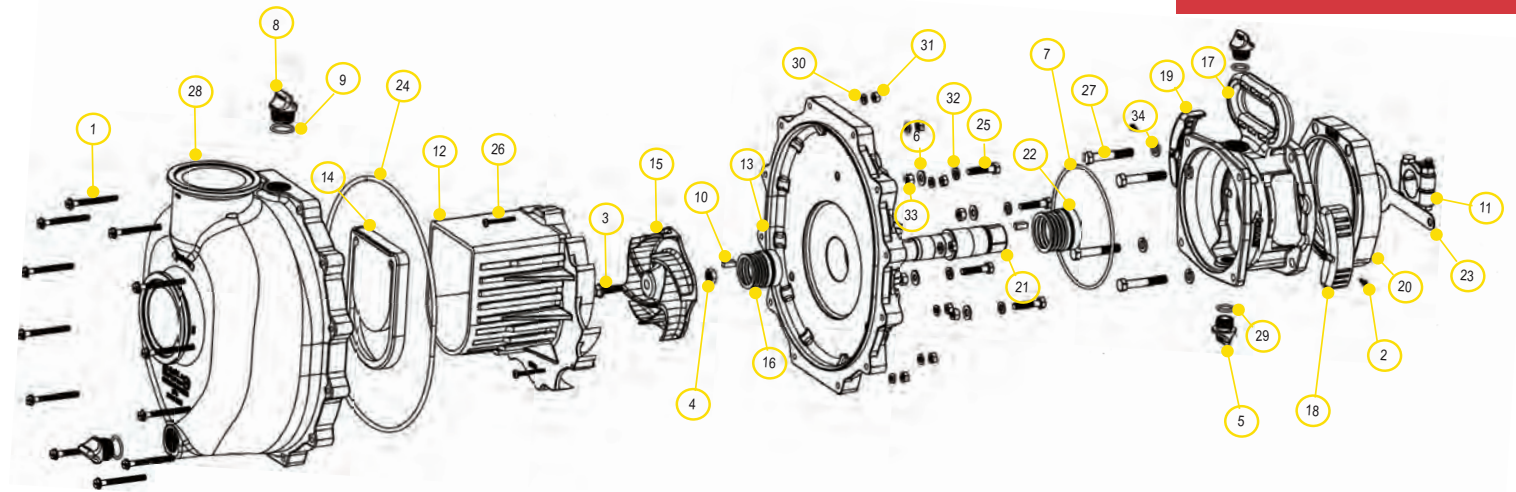

| REPLACEMENT PARTS M350 PUMPS |            |   |             |
|------------------------------|------------|---|-------------|
| ITEM                         | PART NO    | DESCRIPTION                                       | QTY         |
| 1                            | 12720      | 1/4-20 X 2 1/2" SL. IND. HEX WASHER HEAD SCREW    | 12          |
| 2                            | 12725      | #6 X 1/2" PPH SMS                                 | 2           |
| 3                            | 12765A     | 5/16-24 X 1 1/8" HFS                              | 1           |
| 4                            | 12775A     | 7/16-14 HEX NUT                                   | 1           |
| 5                            | 12777      | 1/2" DRAIN PLUG                                   | 2           |
| 6                            | 12901      | 5/16" FLAT WASHER                                 | 8 (4 SHOWN) |
| 7                            | 13719      | AS568A -256 O-RING, EPDM, BLACK                   | 1           |
| 8                            | 13777      | 3/4" DRAIN PLUG, MOLDED                           | 2           |
| 9                            | 13778      | AS568A -119 O-RING, EPDM, BLACK                   | 2           |
| 10                           | 16901SS    | 1/4" SQ. X 5/8" KEY 18-8 SS                       | 2           |
| 11                           | 18029      | SS CLAMP  | 1           |
| 12                           | 35002      | M350 DIFFUSER                                     | 1           |
| 13                           | 35004      | M350 REAR BRACKET                                 | 1           |
| 14                           | 35005      | 3" WET SEAL POLY PUMP CHECK VALVE                 | 1           |
| 15                           | 35073      | M350 5-VANE IMPELLER                              | 1           |
| 16                           | 35113E     | 1.125" MECHANICAL SEAL, EPDM, BULK                | 1           |
| 17                           | 35201      | M350 WET SEAL RESERVOIR                           | 1           |
| 18                           | 35246GL    | LEFT SHAFT GUARD FOR M350P                        | 1           |
| 19                           | 35246GR    | RIGHT SHAFT GUARD FOR M350P                       | 1           |
| 20                           | 35248      | M350 ENGINE SPACER                                | 1           |
| 21                           | 35255A     | 3" WET SEAL POLY PUMP SHAFT ADAPTER FOR BEM15-100 | 1           |
| 22                           | 35313E     | 1.375" MECHANICAL SEAL, EPDM, BULK                | 1           |
| 23                           | 35901      | 350 PUMP SEAL SPACING TOOL                        | 1           |
| 24                           | A380E      | AS568 #380 EPDM O-RING                            | 1           |
| 25                           | B0516138   | 5/16-18 X 1 3/8" HHCS                             | 4           |
| 26                           | B1014150TS | #10 X 1 1/2" THREAD FORMING SCREW, 18-8 SS        | 3           |
| 27                           | BF207      | 3/8-16 X 2 1/4" HHCS                              | 4           |
| 28                           | M35012     | M350 MANIFOLD BODY                                | 1           |
| 29                           | UV15163    | AS568A -114 O-RING, EPDM, BLACK                   | 2           |
| 30                           | V07018     | 1/4" LOCKWASHER                                   | 12          |
| 31                           | V07019     | 1/4"-20 S.S. HEX NUT                              | 12          |
| 32                           | V10118     | 5/16" SS LOCKWASHER                               | 8 (4 SHOWN) |
| 33                           | V10119     | 5/16"-18 SS NUT                                   | 8 (4 SHOWN) |

| REPLACEMENT PARTS M350 PUMPS |         |   |     |
|------------------------------|---------|---|-----|
| ITEM                         | PART NO | DESCRIPTION   | QTY |
| 34                           | V20018  | 3/8" Lockwasher, SS   | 4   |
| 35                           | 17034   | 5/16-18 X 1-1/2" HHCS   | 1   |
| 36                           | 35033   | Z-RAIL FOR M350PH13W  | 1   |
| NS                           | 355800  | BEARING PEDESTAL ASSEMBLY   | 1   |
| NS                           | 35000   | REPAIR KIT REPAIR KIT (CONSIST OF ITEMS 7, 9, 10, 12, 14, 15, 16, 22, 23, 24, 26, 29) | 1   |



## 1½" - 2" CAST IRON PUMPS

### FEATURES

- Cast iron construction for rugged dependable service
- Stainless steel shaft sleeve to protect engine shaft
- Carbon ceramic seal with stainless steel cup and spring with FKM rubber
- Replaceable inlet and outlet flanges
- Dynamically balanced impeller
- Pump only packs complete and ready for attachment to gasoline engine
- Pedestal pump for long coupling to electric motor
- Recommendation for 5/8" shaft: 56C frame size, 3 HP, 3450 RPM & 5" max impeller for close coupling to electric motors
- Recommendation for 7/8" shaft: 145TC frame size, 3 HP, 3450 RPM & 5" max impeller for close coupling to electric motors
- Engine warranty service available at authorized dealers



WARNING! DO NOT RUN PUMP DRY, RESTRICT OR REDUCE PORT SIZES OR DEAD HEAD PUMP



WARNING! DO NOT USE WITH FLAMMABLE LIQUIDS



### 2" CAST IRON PUMP W/GAS ENGINES

| PART NO   | DESCRIPTION   | HP  | QTY | SKID QTY |
|-----------|---|-----|-----|----------|
| 200PI-3   | 2" CAST IRON PUMP W/3.5 HP BRIGGS & STRATTON® ENGINE            | 3.5 | 1   | 8        |
| 200PI6PRO | 2" CAST IRON PUMP W/6.5 HP BRIGGS & STRATTON® ENGINE PRO SERIES | 6.5 | 1   | 8        |
| 200PIH-5  | 2" CAST IRON PUMP W/5.5 HP HONDA® ENGINE                        | 5.5 | 1   | 8        |
| 200PIH5E  | 2" CAST IRON PUMP W/5.5 HP HONDA® ENGINE W/ ELECTRIC START      | 5.5 | 1   | 8        |

### 2" CAST IRON PUMP ONLY

| PART NO | DESCRIPTION                               | HP  | QTY | SKID QTY |
|---------|---|-----|-----|----------|
| 200POI  | 2" CAST IRON PUMP ONLY W/ ¾" SHAFT SLEEVE | N/A | 1   | 27       |

### 1½" CAST IRON C-FLANGE PUMPS

| PART NO         | DESCRIPTION   | HP  | QTY | SKID QTY |
|-----------------|---|-----|-----|----------|
| 150POICF5/8-4.1 | 1½" CAST IRON C-FLANGE PUMP W/ 5/8" SHAFT SLEEVE & 4.1 IMPELLER | N/A | 1   | 18       |

### 2" CAST IRON C-FLANGE PUMPS

| PART NO     | DESCRIPTION                                     | HP  | QTY | SKID QTY |
|-------------|---|-----|-----|----------|
| 200POICF5/8 | 2" CAST IRON C-FLANGE PUMP W/ 5/8" SHAFT SLEEVE | N/A | 1   | 18       |
| 200POICF7/8 | 2" CAST IRON C-FLANGE PUMP W/ 7/8" SHAFT SLEEVE | N/A | 1   | 18       |

### 2" CAST IRON BEARING PEDESTAL

| PART NO | DESCRIPTION  | HP  | QTY | SKID QTY |
|---------|--|-----|-----|----------|
| 200PBI  | 2" CAST IRON BEARING PEDESTAL W/ ¾" STRAIGHT SHAFT | N/A | 1   | 18       |

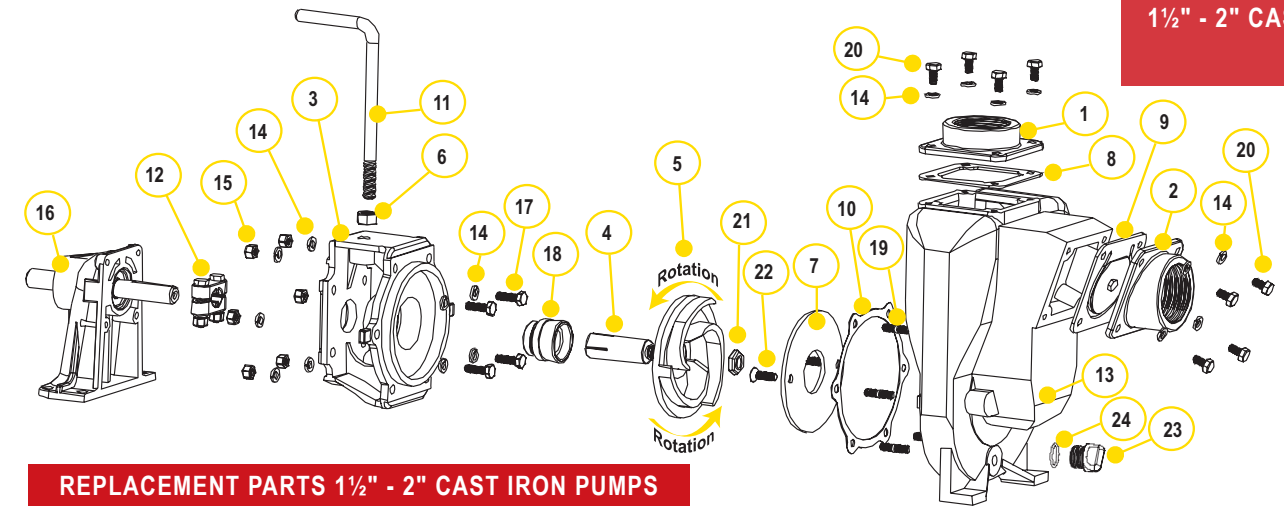

### REPLACEMENT PARTS 1½" - 2" CAST IRON PUMPS

| ITEM | PART NO   | DESCRIPTION                                       | QTY |
|------|-----------|---|-----|
| 1    | 17001     | 1½" NPT OUTLET FLANGE                             | 1   |
| 1    | 17000     | 2" NPT OUTLET FLANGE                              | 1   |
| 2    | 17003     | 1½" NPT INLET FLANGE                              | 1   |
| 2    | 17002     | 2" NPT INLET FLANGE                               | 1   |
| 3    | 17004     | ADAPTER FOR GAS ENGINE                            | 1   |
| 3    | 17046     | C-FACE ADAPTER                                    | 1   |
| 4    | 17005     | 5/8" SLEEVE DRIVE FOR ELECTRIC MOTOR              | 1   |
| 4*   | 17006     | ¾" SLEEVE DRIVE                                   | 1   |
| 4    | 17007     | 7/8" SLEEVE DRIVE FOR ELECTRIC MOTOR              | 1   |
| 5*   | 17008     | 5" IMPELLER                                       | 1   |
| 5    | 17008-4.1 | 4.1" TRIMMED IMPELLER                             | 1   |
| 6    | 17010     | ½" HEX NUT  | 1   |
| 7*   | 17011     | WEAR PLATE  | 1   |
| 8    | 17013     | EPDM GASKET                                       | 1   |
| 9    | 17016     | CHECK VALVE ASSEMBLY                              | 1   |
| 10*  | 17018     | GASKET ADAPTER                                    | 1   |
| 11   | 15022     | HANDLE  | 1   |
| 12   | 17023     | 5/8" CLAMP FOR ¾" SHAFT ASSEMBLY (OLD STYLE)      | 1   |
| 12   | 17123     | 5/8" CLAMP FOR ¾" SHAFT ASSEMBLY (KEYED)          | 1   |
| 12   | 17024     | 7/8" CLAMP FOR SHAFT ASSEMBLY                     | 1   |
| 13   | 17026     | PUMP HOUSING                                      | 1   |
| 14   | V10118    | 5/16" LOCK WASHER                                 | 18  |
| 15   | V10119    | 5/16" - 18 SS HEX NUT                             | 6   |
| N/S  | 12883B    | BEARINGS  | 1   |
| 16   | 12882A    | COMPLETE PEDESTAL ASSEMBLY                        | 2   |
| 17   | 17040     | 5/16" -24 X 1.00" CAP SCREW                       | 1   |
| 18   | 17028     | EPDM SEAL ASSEMBLY                                | 4   |
| 18*  | 17035     | FKM SEAL ASSEMBLY                                 | 1   |
| 18   | 17035SD   | SEVERE DUTY SEAL                                  | 1   |
| 19   | 17042     | STUD  | 6   |
| 20   | 17019     | 5/16"-18 X ¾" CAP SCREW                           | 8   |
| 21   | 17009B    | 5/8" IMPELLER NUT                                 | 1   |
| 22   | 17130     | 5/16-18 X 1.00" FHSCS, 18-8 SS                    | 2   |
| 23   | 12777     | ½" PLUG   | 1   |
| 24   | UV15163   | O-RING  | 1   |
| N/S  | 17033     | Z RAILS (PAIR)                                    | 1   |
| N/S  | 17100     | REPAIR KIT (CONSISTS OF ITEMS 4*, 5*, 7, 10, 18*) | 1   |

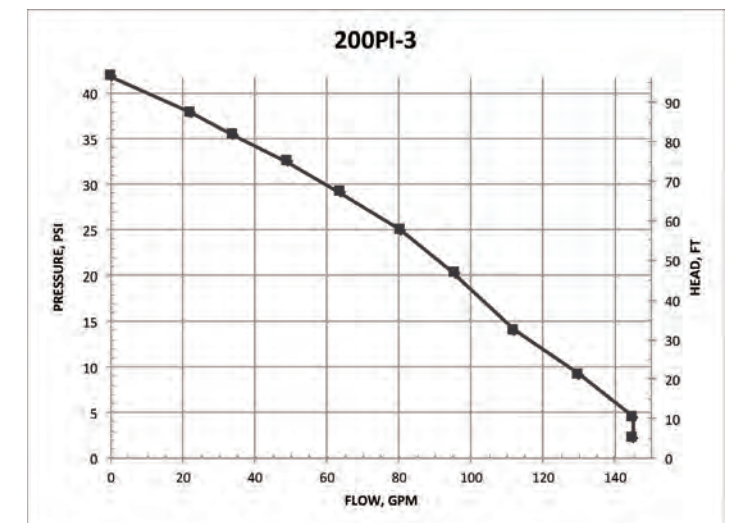

## 1½" - 2" CAST IRON PUMPS

## 2" CAST IRON WET SEAL PUMPS

### FEATURES

- Cast iron construction for rugged dependable service
- Stainless steel hardware
- FKM double seal contained in glycol reservoir
- Replaceable inlet and outlet flanges
- Dynamically balanced impeller
- Pump only packs complete and ready for attachment to gasoline engine
- Pedestal pump for long coupling to electric motor
- Due to weight and size of pumps, Banjo ships these by truck only.



### 2" CAST IRON WET SEAL PUMPS W/GAS ENGINES

| PART NO  | DESCRIPTION                                       | HP  | QTY | SKID QTY |
|----------|---|-----|-----|----------|
| 201PIH5W | 2" CAST IRON WET SEAL PUMP W/5.5 HP HONDA® ENGINE | 5.5 | 1   | 8        |

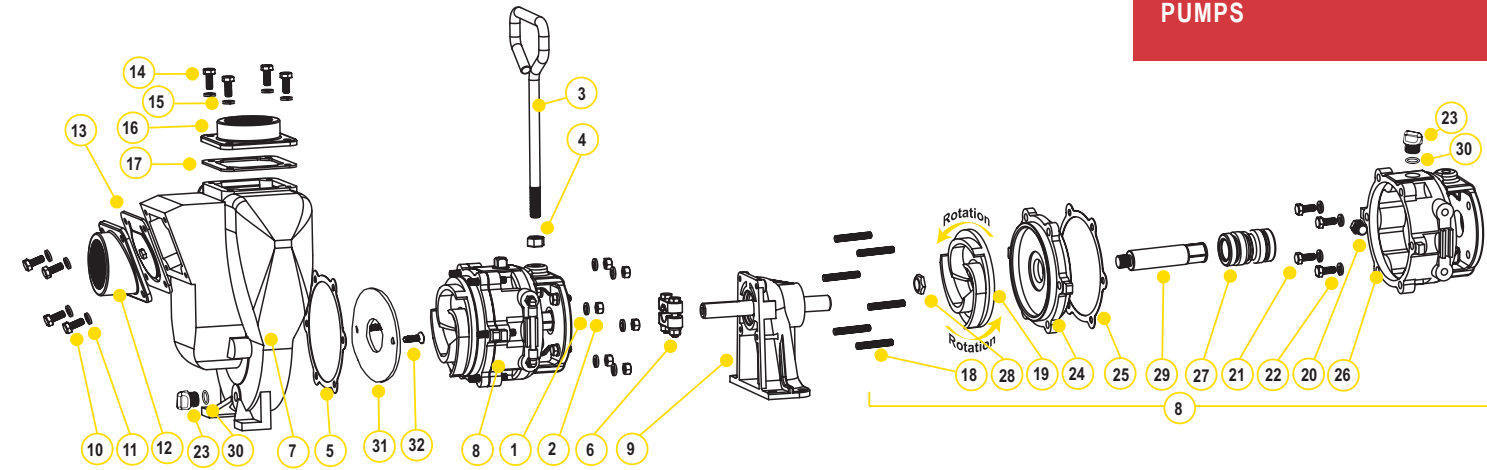

### 2" CAST IRON WET SEAL PUMP ONLY

| PART NO | DESCRIPTION                     | HP  | QTY | SKID QTY |
|---------|---------------------------------|-----|-----|----------|
| 201POIW | 2" CAST IRON WET SEAL PUMP ONLY | N/A | 1   | 18       |



WARNING! DO NOT RUN PUMP DRY, RESTRICT OR REDUCE PORT SIZES OR DEAD HEAD PUMP



WARNING! DO NOT USE WITH FLAMMABLE LIQUIDS



### 2" CAST IRON WET SEAL PUMP BEARING PEDESTAL

| PART NO | DESCRIPTION                                      | HP  | QTY | SKID QTY |
|---------|--|-----|-----|----------|
| 201PBIW | 2" CAST IRON WET SEAL PUMP WITH BEARING PEDESTAL | N/A | 1   | 18       |

### REPLACEMENT PARTS 2" CAST IRON PUMPS

| ITEM | PART NO | DESCRIPTION                           | QTY |
|------|---------|---------------------------------------|-----|
| 1    | V10118  | 5/16" LOCK WASHER                     | 6   |
| 2    | V10119  | 5/16" -18 HEX NUT                     | 6   |
| 3    | 15022   | HANDLE                                | 1   |
| 4    | 17010   | 1/2" HEX NUT                          | 1   |
| 5    | 17018   | GASKET ADAPTER                        | 1   |
| 6    | 17123   | 5/8" CLAMP, 3/4" SHAFT ASSEMBLY KEYED | 1   |
| 7    | 17226   | PUMP HOUSING                          | 1   |
| 8    | N/A     | WET SEAL ASSEMBLY                     | 1   |
| 9    | 12882A  | BEARING PEDESTAL                      | 1   |
| 10   | 17019   | 5/16"-18 X 3/4" HHCS                  | 4   |
| 11   | V10118  | 5/16" LOCK WASHER                     | 4   |
| 12   | 17002   | 2" NPT INLET FLANGE                   | 1   |
| 13   | 17016   | EPDM CHECK VALVE GASKET ASSEMBLY      | 1   |
| 14   | 17019   | 5/16" -18 X 3/4" HHCS                 | 4   |
| 15   | V10118  | 5/16" LOCK WASHER                     | 4   |
| 16   | 17000   | 2" NPT OUTLET FLANGE                  | 1   |
| 17   | 17013   | EPDM OUTLET GASKET                    | 1   |
| 18   | 17242   | HOUSING STUD                          | 6   |
| 19   | 17208   | IMPELLER                              | 1   |
| 20   | 17032   | PIPE PLUG                             | 1   |
| 21   | 17019   | 5/16"-18 X 3/4" CAP SCREW             | 4   |
| 22   | V10118  | 5/16" LOCK WASHER                     | 4   |
| 23   | 12777   | 1/2" PLUG                             | 2   |
| 24   | 17202   | COVER PLATE                           | 1   |
| 25   | 17018   | GASKET ADAPTER                        | 1   |
| 26   | 17201A  | RESERVOIR                             | 1   |
| 27   | 17235   | FKM MECHANICAL SEAL ASSEMBLY          | 1   |
| 28   | 17009B  | 5/8" IMPELLER NUT                     | 1   |
| 29   | 17206A  | ADAPTER SHAFT                         | 1   |
| 30   | UV15163 | O-RING                                | 2   |
| 31   | 17011   | Wear Plate                            | 1   |
| 32   | 17130   | 5/16-18 X 1.00" FHSCS, 18-8 SS        | 1   |

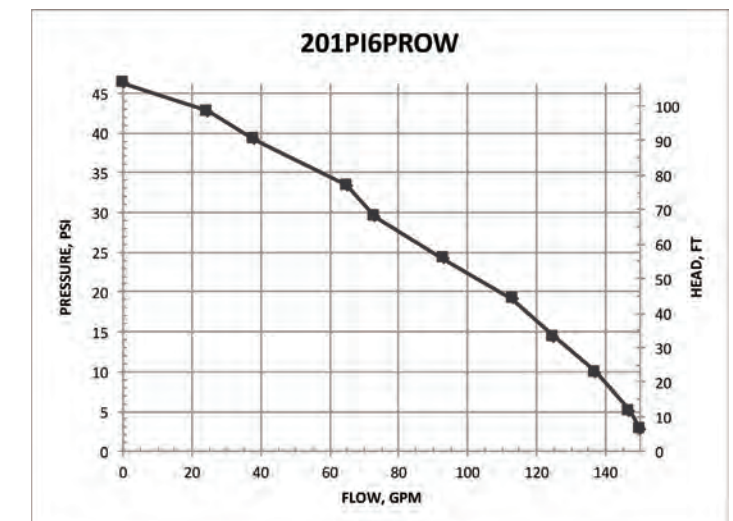

## 2" CAST IRON WET SEAL PUMPS



## 2" CAST IRON PUMPS WITH ELECTRIC MOTORS

### FEATURES

- Cast iron construction for rugged dependable service
- Stainless steel shaft sleeve to protect engine shaft
- Carbon ceramic seal with stainless steel cup and spring with FKM rubber
- Replaceable inlet and outlet flanges
- Dynamically balanced impeller
- Pump only packs complete and ready for attachment to gasoline engine
- Due to weight and size of pumps, Banjo ships these by truck only.
- Motor warranty service available at authorized dealers
- Motor features include pressure cast aluminum end plates with ribbed design for rigidity, heavy gauge steel frame, 230 volt, with inverter spike resistance magnet wire



### 2" CAST IRON PUMPS W/ELECTRIC MOTORS

| PART NO  | DESCRIPTION  | HP | QTY | SKID QTY |
|----------|--|----|-----|----------|
| 234PIE5  | 2" CAST IRON PUMP W/5 HP THREE PHASE ELECTRIC MOTOR  | 5  | 1   | 3        |
| 234PIE51 | 2" CAST IRON PUMP W/5 HP SINGLE PHASE ELECTRIC MOTOR | 5  | 1   | 3        |

### 2" CAST IRON PUMP ONLY

| PART NO | DESCRIPTION                                  | HP  | QTY | SKID QTY |
|---------|--|-----|-----|----------|
| 234POI  | 2" CAST IRON PUMP ONLY W 184TC FRAME ADAPTER | N/A | 1   | 18       |



**WARNING! DO NOT RUN PUMP DRY, RESTRICT OR REDUCE PORT SIZES OR DEAD HEAD PUMP**



**WARNING! DO NOT USE WITH FLAMMABLE LIQUIDS**

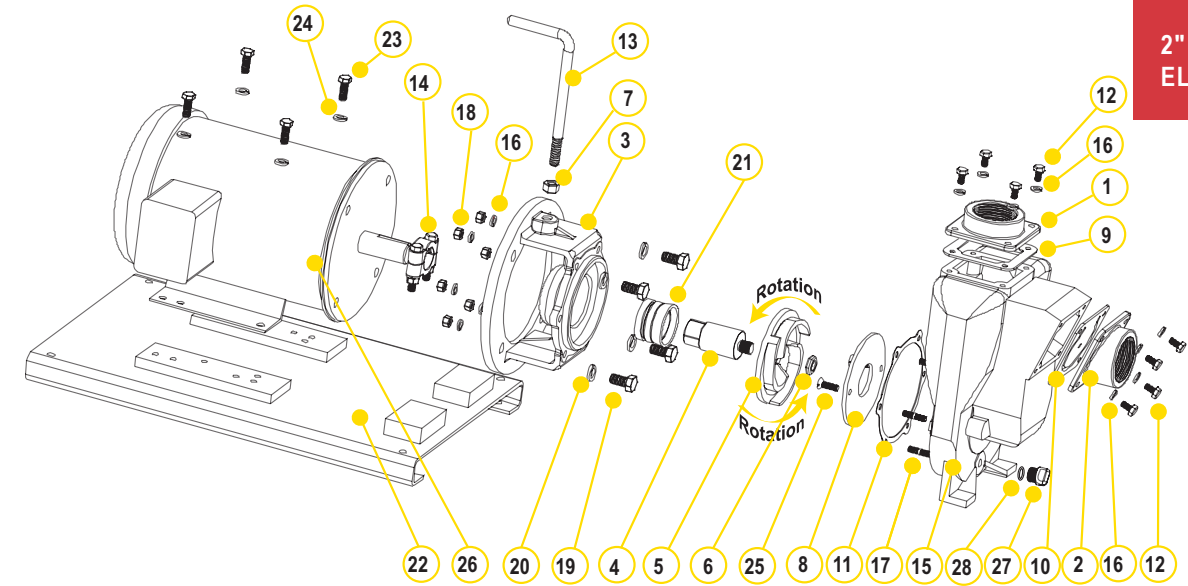

### REPLACEMENT PARTS 2" CAST IRON PUMPS

| ITEM | PART NO | DESCRIPTION                    | QTY |
|------|---------|--------------------------------|-----|
| 1    | 17000   | 2" NPT OUTLET FLANGE           | 1   |
| 2    | 17002   | 2" NPT INLET FLANGE            | 1   |
| 3    | 17046   | C-FACE ADAPTER (234PIE3)       | 1   |
| 3    | 17446   | C-FACE ADAPTER                 | 1   |
| 4    | 17007   | IMPELLER SHAFT (234PIE3)       | 1   |
| 4    | 17406   | IMPELLER SHAFT                 | 1   |
| 5    | 17008   | IMPELLER (234PIE3)             | 1   |
| 5    | 17408   | IMPELLER                       | 1   |
| 6    | 17009B  | 5/8" IMPELLER NUT              | 1   |
| 7    | 17010   | 1/2" HEX NUT                   | 1   |
| 8    | 17011   | WEAR PLATE                     | 1   |
| 9    | 17013   | OUTLET GASKET                  | 1   |
| 10   | 17016   | GASKET & CHECK VALVE           | 1   |
| 11   | 17018   | GASKET ADAPTER                 | 1   |
| 12   | 17019   | BOLT                           | 8   |
| 13   | 15022   | HANDLE                         | 1   |
| 14   | 17024   | CLAMP ASSEMBLY W/KEY (234PIE3) | 1   |
| 14   | 18129   | CLAMP ASSEMBLY W/KEY           | 1   |
| 15   | 17026   | PUMP HOUSING                   | 1   |
| 16   | V10118  | 5/16" LOCK WASHER              | 20  |
| 17   | 17042   | HOUSING STUD                   | 6   |
| 18   | V10119  | HEX NUT                        | 8   |
| 19   | N/A     | BOLT                           | 4   |
| 20   | N/A     | WASHER                         | 4   |
| 21   | 17035   | SEAL ASSEMBLY (234PIE3)        | 1   |
| 21   | 18025   | SEAL ASSEMBLY                  | 1   |
| 22   | 17701   | BASE PLATE ASSEMBLY            | 1   |
| 23   | 17704   | BOLT                           | 4   |
| 24   | V20018  | 3/8" LOCK WASHER               | 4   |
| 25   | 17130   | 5/16-18 X 1.00" FHSCS, 18-8 SS | 2   |
| 26   | N/A     | ELECTRIC MOTOR                 | 1   |
| 27   | 12777   | 1/2" PLUG                      | 1   |
| 28   | UV15163 | O-RING FOR DRAIN PLUG          | 1   |

## 2" CAST IRON PUMPS WITH ELECTRIC MOTORS

**234 SERIES PUMP**

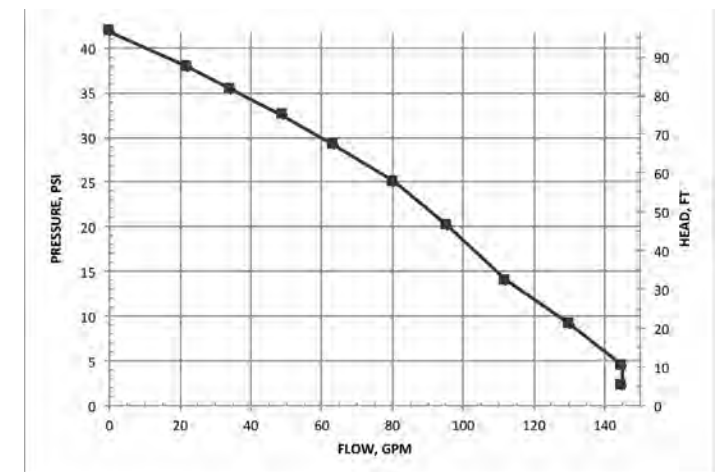

## 2" CAST IRON PUMPS WITH HYDRAULIC MOTORS

### FEATURES

- Cast iron construction for rugged dependable service
- Stainless steel hardware
- Replaceable inlet and outlet flanges
- Dynamically balanced impeller
- Hydraulic fluid capacity is minimum 6 gallons and maximum 10 gallons
- Open or closed system
- 12 HP motor
- Recommendation to use the motor spool control valve or a suitable equivalent. The lack of such a valve in this circuit may cause failure to the hydraulic motor and will void warranty.



| 2" CAST IRON PUMPS WITH HYDRAULIC MOTOR |   |    |     |          |
|---|---|----|-----|----------|
| PART NO                                 | DESCRIPTION                                 | HP | QTY | SKID QTY |
| 200PIHY                                 | 2" CAST IRON PUMP ONLY WITH HYDRAULIC MOTOR | 12 | 1   | 18       |

### SPOOL VALVE ASSEMBLY DIAGRAM

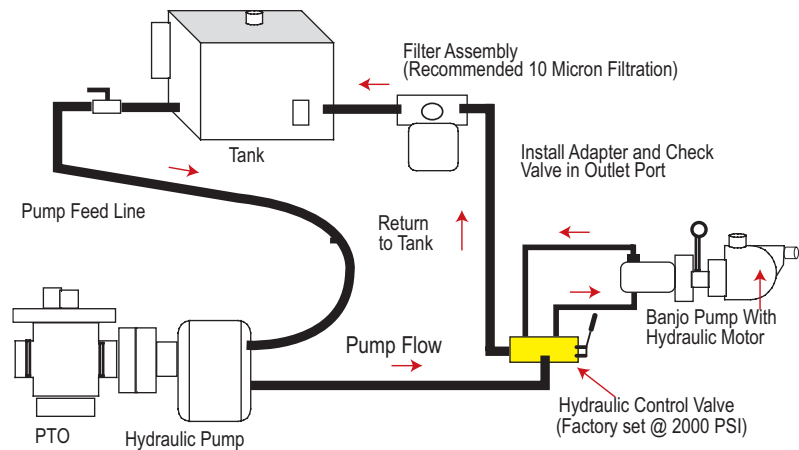

| HYDRAULIC MOTOR SPOOL VALVE |                             |     |     |
|-----------------------------|-----------------------------|-----|-----|
| PART NO                     | DESCRIPTION                 | HP  | QTY |
| HSV1000                     | HYDRAULIC MOTOR SPOOL VALVE | N/A | 1   |

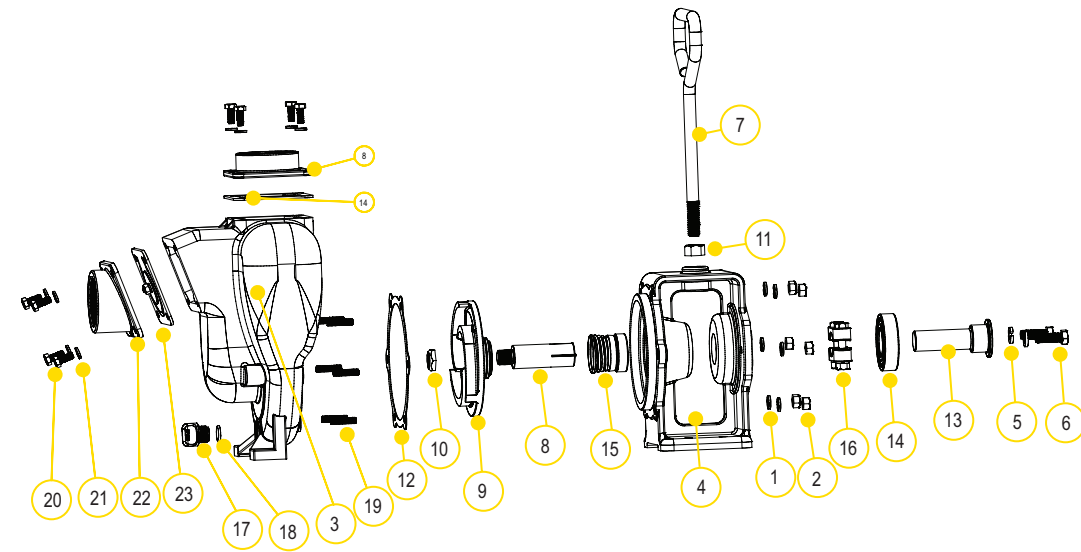

### REPLACEMENT PARTS 2" CAST IRON PUMPS

| ITEM | PART NO | DESCRIPTION                           | QTY |
|------|---------|---------------------------------------|-----|
| 1    | V10118  | 5/16" SPLIT LOCK WASHER               | 6   |
| 2    | V10119  | 5/16"-18 HEX NUT                      | 6   |
| 3    | 17026   | PUMP HOUSING                          | 1   |
| 4    | 17049A  | HYDRAULIC ADAPTER                     | 1   |
| 5    | V20018  | 3/8" LOCK WASHER                      | 2   |
| 6    | 18010SS | 3/8"-16 X 1.25" HHCS                  | 2   |
| 7    | 15022   | HANDLE                                | 1   |
| 8    | 17007   | 7/8" SLEEVE DRIVE FOR HYDRAULIC MOTOR | 1   |
| 9    | 17008   | 5" IMPELLER                           | 1   |
| 10   | 17009B  | 5/8" IMPELLER NUT                     | 1   |
| 11   | 17010   | 1/2" HEX NUT - 13UNF-RH               | 1   |
| 12   | 17018   | GASKET ADAPTER                        | 1   |
| 13   | 17055A  | HYDRAULIC ADAPTER SHAFT               | 1   |
| 14   | 17056   | SKF 6206-2RS1 BEARING                 | 1   |
| 15   | 17035   | FKM SEAL ASSEMBLY                     | 1   |
| 16   | 17024   | 7/8" CLAMP, NO KEY                    | 1   |
| 17   | 12777   | 1/2" PLUG                             | 1   |
| 18   | UV15163 | O-RING                                | 1   |

-PY1013 MOTOR ONLY

## 2" CAST IRON PUMPS WITH HYDRAULIC MOTORS

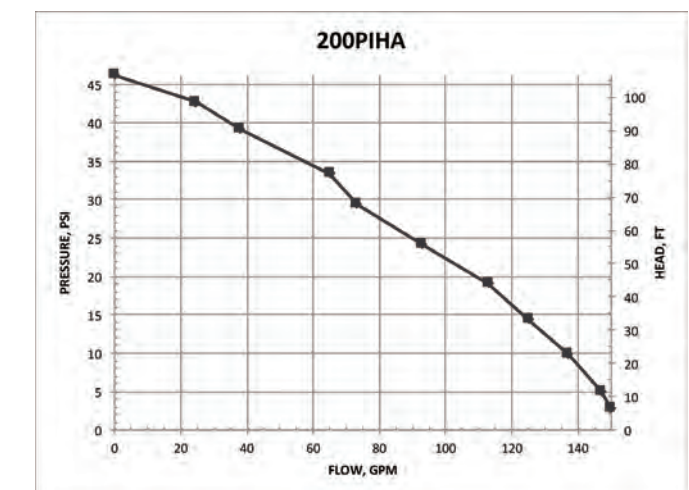
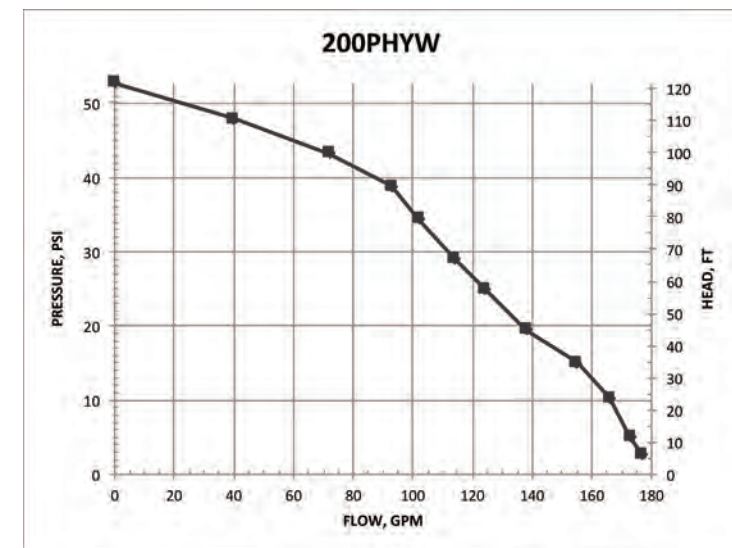

WARNING! DO NOT RUN PUMP DRY, RESTRICT OR REDUCE PORT SIZES OR DEAD HEAD PUMP



WARNING! DO NOT USE WITH FLAMMABLE LIQUIDS



## 2" 222 SERIES CAST IRON PUMPS

### FEATURES

- Cast iron construction for rugged dependable service
- Carbon ceramic seal with stainless steel cup and spring with FKM rubber
- Replaceable inlet and outlet flanges
- Dynamically balanced impeller
- Heavy duty slinger seal on motor shaft
- Large weep holes between pump end and engine
- Pump only packs complete and ready for attachment to gasoline engine
- Pedestal pump for long coupling to electric motor
- Recommendation for 3/4" shaft: 5 HP, 3600 RPM
- Due to weight and size of pumps, Banjo ships these by truck only.
- Engine warranty service available at authorized dealers

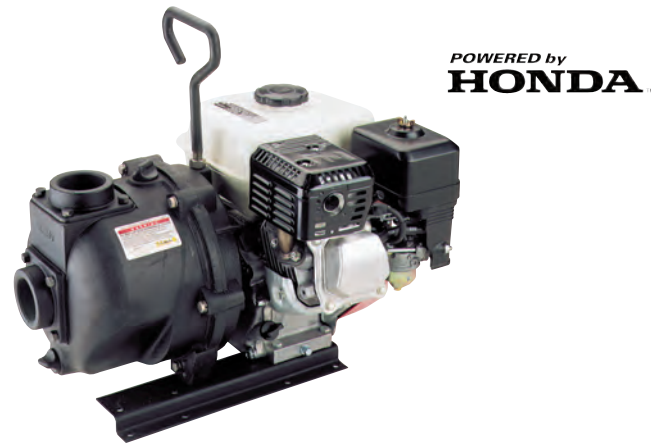

POWERED by  
**HONDA**

| 222 SERIES CAST IRON PUMPS W/GAS ENGINES |   |     |     |          |
|--|---|-----|-----|----------|
| PART NO                                  | DESCRIPTION   | HP  | QTY | SKID QTY |
| 222PIH5                                  | 2" CAST IRON PUMP W/5.5 HP HONDA® ENGINE                        | 5.5 | 1   | 8        |
| 222PIH6                                  | 2" CAST IRON PUMP W/6.5 HP HONDA® ENGINE                        | 6.5 | 1   | 8        |
| 222PIH5E                                 | 2" CAST IRON PUMP W/5.5 HP HONDA® ENGINE W/ ELECTRIC START      | 5.5 | 1   | 8        |
| 222PI6PRO                                | 2" CAST IRON PUMP W/6.5 HP BRIGGS & STRATTON® ENGINE PRO SERIES | 6.5 | 1   | 8        |



| 222 SERIES CAST IRON PUMP ONLYS |   |     |     |          |
|---------------------------------|---|-----|-----|----------|
| PART NO                         | DESCRIPTION                             | HP  | QTY | SKID QTY |
| 222POI                          | 2" CAST IRON PUMP ONLY W/ FULL IMPELLER | N/A | 1   | 18       |



| 222 SERIES CAST IRON BEARING PEDESTAL |  |     |     |          |
|---------------------------------------|--|-----|-----|----------|
| PART NO                               | DESCRIPTION  | HP  | QTY | SKID QTY |
| 222PBI                                | 2" CAST IRON BEARING PEDESTAL W/ 3/4" STRAIGHT KEYED SHAFT | N/A | 1   | 18       |



WARNING! DO NOT RUN PUMP DRY, RESTRICT OR REDUCE PORT SIZES OR DEAD HEAD PUMP



WARNING! DO NOT USE WITH FLAMMABLE LIQUIDS

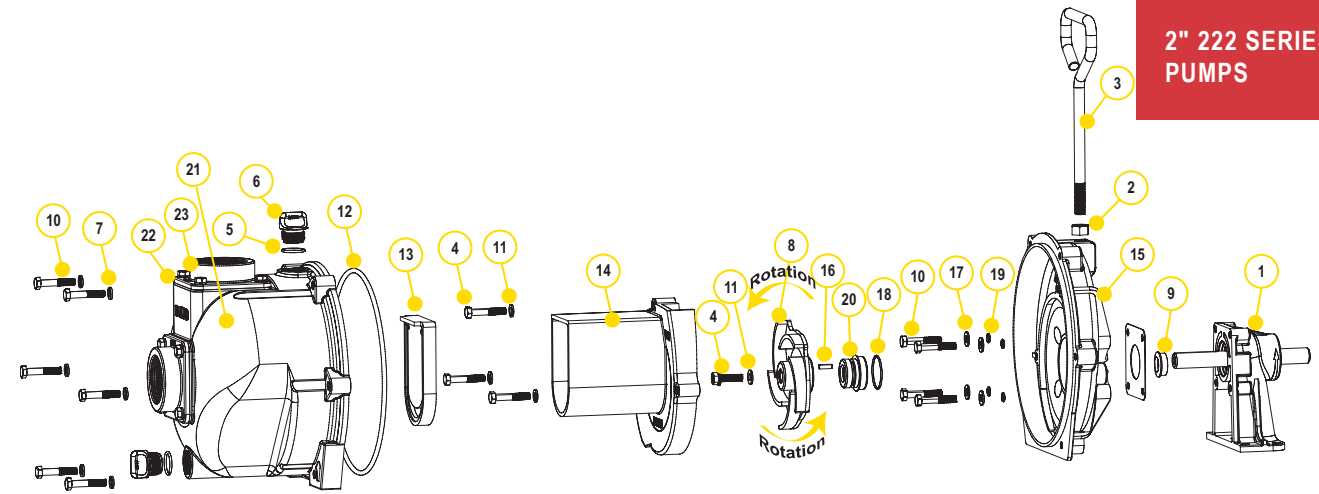

## 2" 222 SERIES CAST IRON PUMPS

| REPLACEMENT PARTS 2" CAST IRON PUMPS |         |   |        |
|--------------------------------------|---------|---|--------|
| ITEM                                 | PART NO | DESCRIPTION   | QTY    |
| 1                                    | 12882A  | BEARING PEDESTAL ASSEMBLY                                   | 1      |
| 1                                    | 12600B  | HYDRAULIC PEDESTAL ASSEMBLY                                 | 1      |
| 2                                    | 17010   | 1/2" JAM NUT  | 1      |
| 3                                    | 15022   | HANDLE  | 1      |
| 4                                    | 12765A  | 5/16" - 24 X 1.12 IMPELLER BOLT                             | 1      |
| 5                                    | 13778   | O-RING  | 2      |
| 6                                    | 13777   | 3/4" PLUG   | 2      |
| 7                                    | V10118  | 5/16" LOCK WASHER   | 9      |
| 8                                    | 15772   | 5 VANE IMPELLER   | 1      |
| 9                                    | 12716   | PUMP SLINGER  | 1      |
| 10                                   | 12715A  | 5/16" - 24 X 1.75 HHCS                                      | 13     |
| 11                                   | A204    | O-RING  | 1      |
| 12                                   | 12719A  | BODY O-RING   | 1      |
| 13                                   | 12705   | CHECK VALVE   | 1      |
| 14                                   | 15702   | VOLUTE  | 1      |
| 15                                   | 15703   | REAR BRACKET  | 1      |
| 16                                   | 12902A  | 3/16" SQ X 5/8" KEY   | 1      |
| 17                                   | 12901   | 5/16" FLAT WASHER   | 4      |
| 18                                   | 12710   | O-RING  | 1      |
| 19                                   | 12717   | O-RING  | 4      |
| 20                                   | 12713V  | SEAL ASSEMBLY   | 1      |
| 20                                   | N/A     | SEVERE DUTY SEAL  | 1      |
| 21                                   | 15712   | BODY  | 1      |
| 22                                   | 17013   | FLANGE GASKET   | 2      |
| 23                                   | 17000   | 2" NPT THREADED FLANGE                                      | 2      |
| 24                                   | 17019   | 5/16" - 18 X 0.75 HHCS                                      | 8      |
| 25                                   | V10118  | 5/16" LOCK WASHER   | 8      |
| N/S                                  | 12099   | 7/16"-14 X 1.25" HHCS                                       | 1      |
| N/S                                  | 15751   | BRACKET SHIM  | 1      |
| N/S                                  | 15752   | IMPELLER SHIM   | 1      |
| N/S                                  | 17033   | Z-RAILS   | 1 PAIR |
| N/S                                  | N/A     | 5/16" - 18 X 1 3/4" ZINC PLATED                             | 4      |
| N/S                                  | V10119  | 5/16" - 18 HEX NUT  | 4      |
| N/S                                  | V10118  | 5/16" LOCK WASHER   | 4      |
| N/S                                  | 15000   | REPAIR KIT (ITEMS 5, 8, 11-12, 18-20, 12099, 15751 & 15752) | 1      |
| N/S                                  | 15000V  | FKM REPAIR KIT  | 1      |
| N/S                                  | 15999   | SEAL KIT (ITEMS 5, 11-12, 18-20, 12099, 15751 & 15752)      | 1      |
| N/S                                  | 15999V  | FKM SEAL KIT  | 1      |

| KITS 222 CAST IRON PUMPS |                    |                   |                  |                 |
|--------------------------|--------------------|-------------------|------------------|-----------------|
| PART NO                  | EPDM REPAIR KIT NO | FKM REPAIR KIT NO | EPDM SEAL KIT NO | FKM SEAL KIT NO |
| 222PIH5                  | 15000              | 15000V            | 15999            | 15999V          |
| 222PIH6                  | 15000              | 15000V            | 15999            | 15999V          |
| 222PIH5E                 | 15000              | 15000V            | 15999            | 15999V          |
| 222PI6PRO                | 15000              | 15000V            | 15999            | 15999V          |
| 222POI                   | 15000              | 15000V            | 15999            | 15999V          |
| 222PBI                   | 15000              | 15000V            | 15999            | 15999V          |

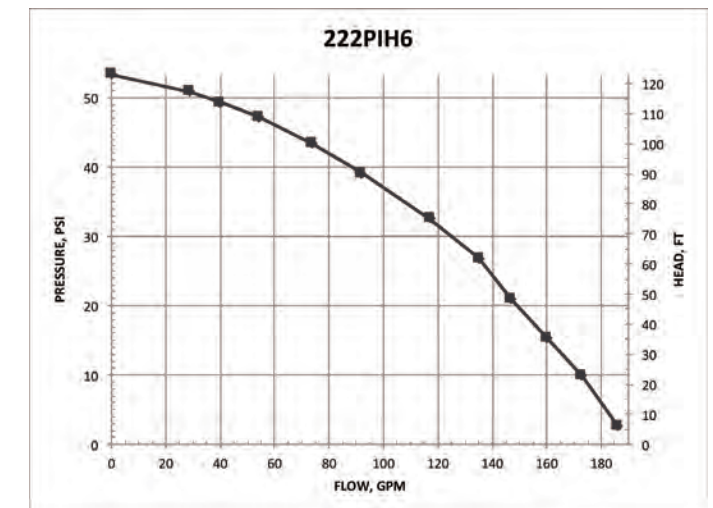

## 2" 222 SERIES CAST IRON PUMPS WITH ELECTRIC MOTORS

### FEATURES

- Cast iron construction for rugged dependable service
- Carbon ceramic seal with stainless steel cup and spring with FKM rubber
- Replaceable inlet and outlet flanges
- Dynamically balanced impeller
- Heavy duty slinger seal on motor shaft
- Large weep holes between pump end and engine
- Motor features include pressure cast aluminum end plates with ribbed design for rigidity, heavy gauge steel frame, 230 volt, with inverter spike resistance magnet wire
- Due to weight and size of pumps, Banjo ships these by truck only.



| 222 SERIES CAST IRON PUMPS W/ELECTRIC MOTORS |  |    |     |          |
|--|--|----|-----|----------|
| PART NO                                      | DESCRIPTION  | HP | QTY | SKID QTY |
| 222PIE5                                      | 2" CAST IRON PUMP W/5 HP THREE PHASE ELECTRIC MOTOR  | 5  | 1   | 3        |
| 222PIE51                                     | 2" CAST IRON PUMP W/5 HP SINGLE PHASE ELECTRIC MOTOR | 5  | 1   | 3        |



WARNING! DO NOT RUN PUMP DRY, RESTRICT OR REDUCE PORT SIZES OR DEAD HEAD PUMP



WARNING! DO NOT USE WITH FLAMMABLE LIQUIDS

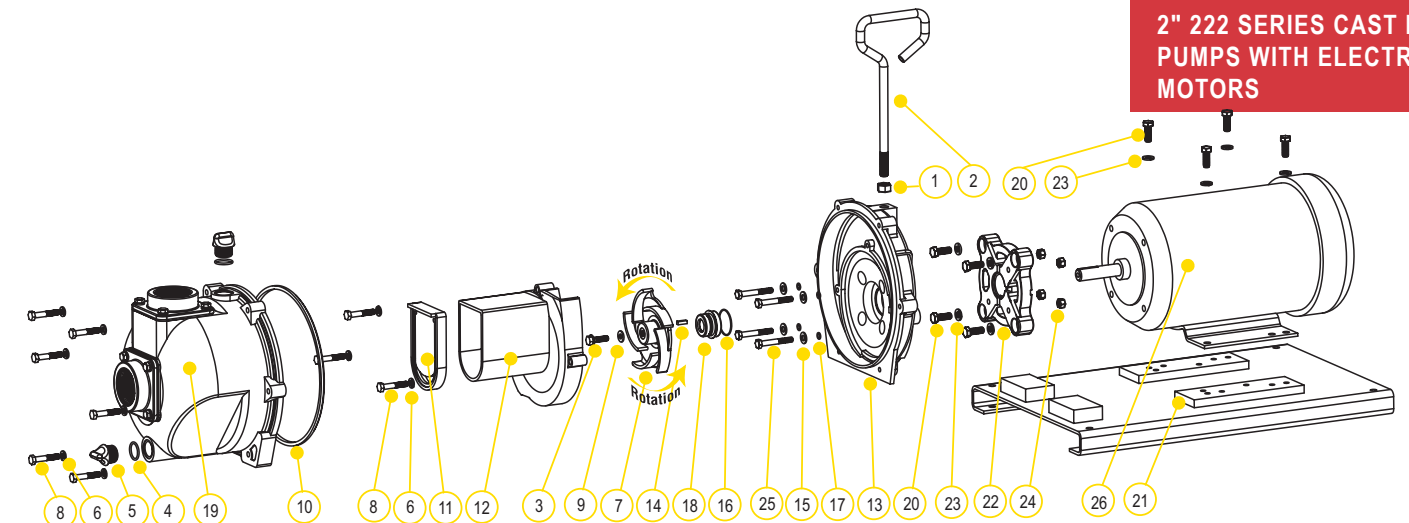

## 2" 222 SERIES CAST IRON PUMPS WITH ELECTRIC MOTORS

### REPLACEMENT PARTS 222 SERIES CAST IRON PUMPS

| ITEM | PART NO     | DESCRIPTION   | QTY |
|------|-------------|---|-----|
| 1    | 17010       | 1/2" JAM NUT  | 1   |
| 2    | 15022       | HANDLE  | 1   |
| 3    | 12765A      | 5/16" - 24 X 1.12 IMPELLER BOLT                                       | 1   |
| 4    | 13778       | O-RING  | 2   |
| 5    | 13777       | 3/4" PLUG   | 2   |
| 6    | V10118      | 5/16" LOCK WASHER   | 9   |
| 7    | 15772       | 5 VANE IMPELLER   | 1   |
| 8    | 12715A      | 5/16" - 24 X 1.75 HHCS  | 13  |
| 9    | A204        | O-RING  | 1   |
| 10   | 12719A      | BODY O-RING   | 1   |
| 11   | 12705       | CHECK VALVE   | 1   |
| 12   | 15702       | VOLUTE  | 1   |
| 13   | 15703       | REAR BRACKET  | 1   |
| 14   | 12902A      | 3/16" SQ. X 5/8" KEY  | 1   |
| 15   | 12901       | 5/16" FLAT WASHER   | 1   |
| 16   | 12710       | O-RING  | 4   |
| 17   | 12717       | O-RING  | 1   |
| 18   | 12713V      | SEAL ASSEMBLY   | 4   |
| 18   | N/A         | SEVERE DUTY SEAL  | 1   |
| 19   | 15712       | BODY  | 1   |
| 20   | 17704       | 3/16" - 16 X 1.25 HHCS BOLT   | 8   |
| 21   | 17701       | C-FACED BASE PLATE  | 1   |
| 22   | 12046       | 56C ADAPTER   | 1   |
| 23   | V20018      | 3/8" LOCK WASHER  | 8   |
| 24   | V20019      | 3/8" 16 SS HEX NUT  | 4   |
| 25   | N/A         | 5/16" - 18 X 2 1/4" HHCS BOLT   | 4   |
| 26   | BEM5-182CZ  | 5 HP 3450 RPM THREE PHASE MOTOR                                       | 1   |
| 26   | BEM51-182CZ | 5 HP 3450 RPM SINGLE PHASE MOTOR                                      | 1   |
| N/S  | 12099       | 7/16"-14 X 1.25" HHCS   | 1   |
| N/S  | 15751       | BRACKET SHIM  | 1   |
| N/S  | 15752       | IMPELLER SHIM   | 1   |
| N/S  | 12756       | ADAPTER KIT (ITEMS 14, 20, 22, 23, 12052, 12053, 15751, 15752, 17029) | 1   |
| N/S  | 15000       | REPAIR KIT (ITEMS 4,7,9-11,14,16-18,12099,15751 & 15752)              | 1   |
| N/S  | 15000V      | FKM REPAIR KIT  | 1   |
| N/S  | 15999       | SEAL KIT (ITEMS 4, 9-11, 14,16-18,12099,15751 & 15752)                | 1   |
| N/S  | 15999V      | FKM SEAL KIT  | 1   |

### KITS 222 CAST IRON PUMPS

| PART NO  | EPDM REPAIR KIT NO | FKM REPAIR KIT NO | EPDM SEAL KIT NO | ADAPTER KIT NO |
|----------|--------------------|-------------------|------------------|----------------|
| 222PIE5  | 15000              | 15000V            | 15999            | 12756          |
| 222PIE51 | 15000              | 15000V            | 15999            | 12756          |

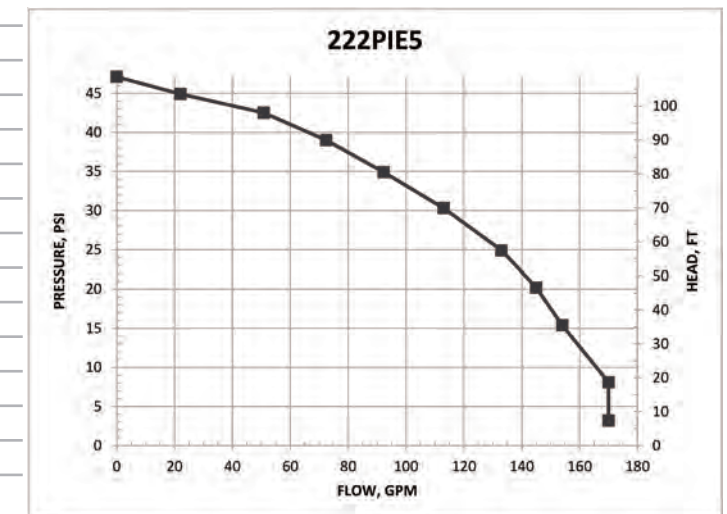



## 3" CAST IRON PUMPS

### FEATURES

- Cast iron construction for rugged dependable service
- Stainless steel shaft sleeve to protect engine shaft
- Carbon ceramic seal with stainless steel cup and spring with FKM rubber
- Replaceable inlet and outlet flanges
- Dynamically balanced impeller
- Pump only packs complete and ready for attachment to gasoline engine
- Bearing pedestal pump for long coupling to electric motor
- Recommendation for 1" shaft: 184TC frame size, 7½ HP, 3450 RPM for close coupling to electric motors
- Engine warranty service available at authorized dealers
- Due to weight and size of pumps, Banjo ships these by truck only.

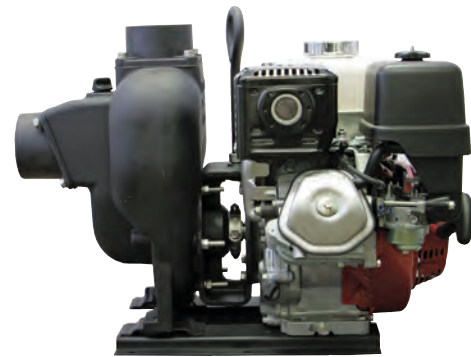

### 3" CAST IRON PUMP W/GAS ENGINES

| PART NO  | DESCRIPTION  | HP | QTY | SKID QTY |
|----------|--|----|-----|----------|
| 300PIH13 | 3" CAST IRON PUMP W/13 HP HONDA® ENGINE W/ELECTRIC START & PULL ROPE | 13 | 1   | 6        |



### 3" CAST IRON PUMP ONLY

| PART NO    | DESCRIPTION                                   | HP  | QTY | SKID QTY |
|------------|---|-----|-----|----------|
| 300POI     | 3" CAST IRON PUMP ONLY W/ 1" SHAFT SLEEVE     | N/A | 1   | 8        |
| 300POICF   | 3" CAST IRON PUMP WITH C-FLANGE               | N/A | 1   | 8        |
| 300POICF55 | 3" CAST IRON PUMP WITH C-FACE W/5 ½" IMPELLER | N/A | 1   | 8        |

WILL FIT A 184TC FRAME SIZE



### 3" CAST IRON BEARING PEDESTAL

| PART NO | DESCRIPTION  | HP  | QTY | SKID QTY |
|---------|--|-----|-----|----------|
| 300PBI  | 3" CAST IRON BEARING PEDESTAL W/ 1" STRAIGHT SHAFT | N/A | 1   | 8        |

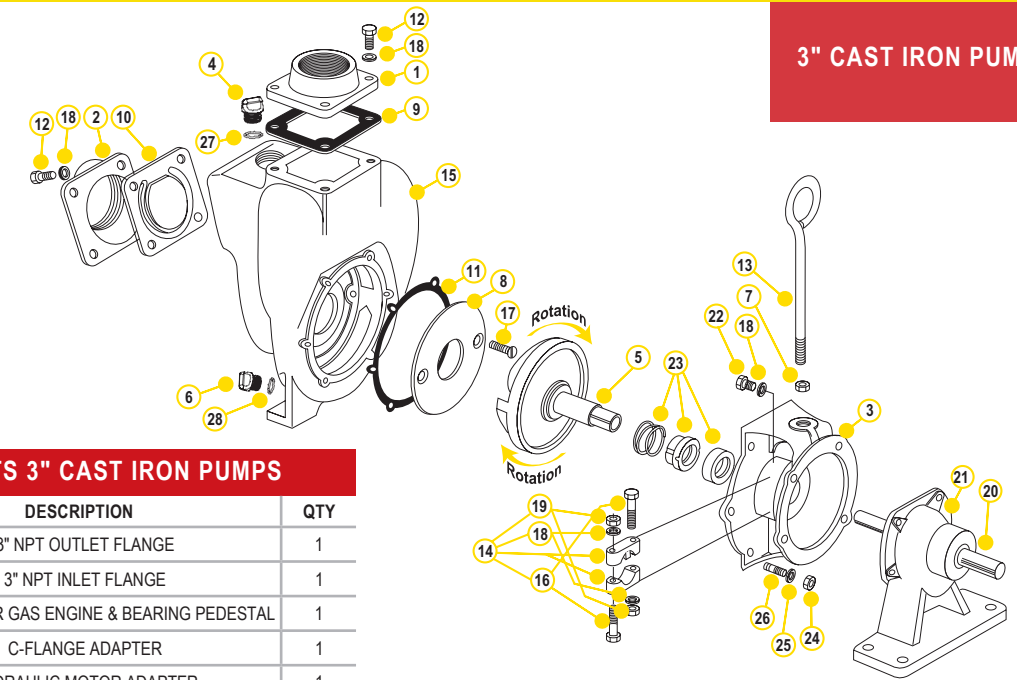

### REPLACEMENT PARTS 3" CAST IRON PUMPS

| ITEM | PART NO       | DESCRIPTION                                    | QTY |
|------|---------------|--|-----|
| 1    | 18008         | 3" NPT OUTLET FLANGE                           | 1   |
| 2    | 18012         | 3" NPT INLET FLANGE                            | 1   |
| 3    | 18026         | ADAPTER FOR GAS ENGINE & BEARING PEDESTAL      | 1   |
| 3    | 18048         | C-FLANGE ADAPTER                               | 1   |
| 3    | 18049         | HYDRAULIC MOTOR ADAPTER                        | 1   |
| N/S  | 18055         | HYDRAULIC ADAPTER SHAFT                        | 1   |
| 4    | 13777         | ¾" PLUG  | 1   |
| 5*   | 18023SS       | 1" IMPELLER & DRIVE SHAFT FOR GAS ENGINE       | 1   |
| 5    | 18023-1.125SS | 1½" IMPELLER & DRIVE SHAFT FOR ELECTRIC MOTOR  | 1   |
| 6    | 12777         | ½" PLUG  | 1   |
| 7    | 18034         | ⅝" SS JAM NUT                                  | 1   |
| 8    | 18004         | WEAR PLATE                                     | 1   |
| 9    | 18009         | EPDM OUTLET GASKET                             | 1   |
| 10   | 18013         | GASKET CHECK VALVE ASSEMBLY                    | 1   |
| 11   | 18021         | ADAPTER GASKET                                 | 1   |
| 12   | 18010SS       | ⅜" - 16 X 1½" SS CAP SCREW HXHD                | 8   |
| 13   | 18033         | HANDLE   | 1   |
| 14   | 18029         | CLAMP ASSEMBLY (OLD STYLE)                     | 1   |
| 14   | 18129         | CLAMP ASSEMBLY (NEW STYLE)                     | 1   |
| 15   | 18001         | PUMP HOUSING                                   | 1   |
| 16   | N/A           | ⅜" -24 X 2¼" BOLT                              | 2   |
| 17   | 18106         | WEAR PLATE FLAT HEAD SCREW                     | 2   |
| 18   | V20018        | ⅜" LOCK WASHER                                 | 8   |
| 19   | N/A           | ⅜" X 24 SS HEX NUT                             | 2   |
| 20   | 18504         | 1" SHAFT                                       | 1   |
| 21   | 18500         | BEARING PEDESTAL                               | 1   |
| N/S  | 18502         | BEARING SKF 66306-2RS1/C3                      | 2   |
| 22   | 17704         | BOLT   | 4   |
| 23*  | 18025         | FKM SEAL ASSEMBLY                              | 1   |
| 23   | 18025SD       | SEVERE DUTY SEAL                               | 1   |
| 24   | V20019        | ⅜" 16 SS HEX NUT                               | 6   |
| 25   | V20018        | ⅜" SS LOCK WASHER                              | 6   |
| 26   | 18218         | ⅜" -16 X 24 X 2½" SS STUD                      | 6   |
| 27   | 13778         | O-RING   | 1   |
| 28   | UV15163       | O-RING   | 1   |
| N/S  | 18035         | Z-RAIL MOUNTING BRACKET (PAIR)                 | 1   |
| N/S  | 18100         | REPAIR KIT (CONSIST OF ITEMS 5*, 8,11,17, 23*) | 1   |



WARNING! DO NOT RUN PUMP DRY, RESTRICT OR REDUCE PORT SIZES OR DEAD HEAD PUMP



WARNING! DO NOT USE WITH FLAMMABLE LIQUIDS

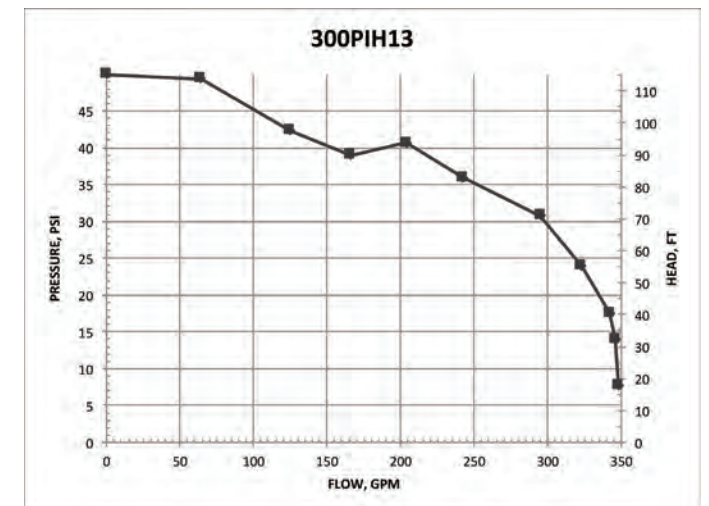

## 3" CAST IRON PUMPS

## 3" CAST IRON WET SEAL PUMPS

## 3" CAST IRON WET SEAL PUMPS

### FEATURES

- Cast iron construction for rugged dependable service
- Run dry capability
- Stainless steel hardware
- Double seal contained in ethylene glycol reservoir
- Replaceable inlet and outlet flanges
- Dynamically balanced impeller
- Pump only packs complete and ready for attachment to gasoline engine
- Pedestal pump for long coupling to electric motor
- Due to weight and size of pumps, Banjo ships these by truck only.



| 3" CAST IRON WET SEAL PUMPS W/GAS ENGINES |  |    |     |          |
|---|--|----|-----|----------|
| PART NO                                   | DESCRIPTION  | HP | QTY | SKID QTY |
| 301PIH13W                                 | 3" CAST IRON WET SEAL PUMP W/13 HP HONDA® ENGINE W/ ELECTRIC START & PULL ROPE | 13 | 1   | 6        |

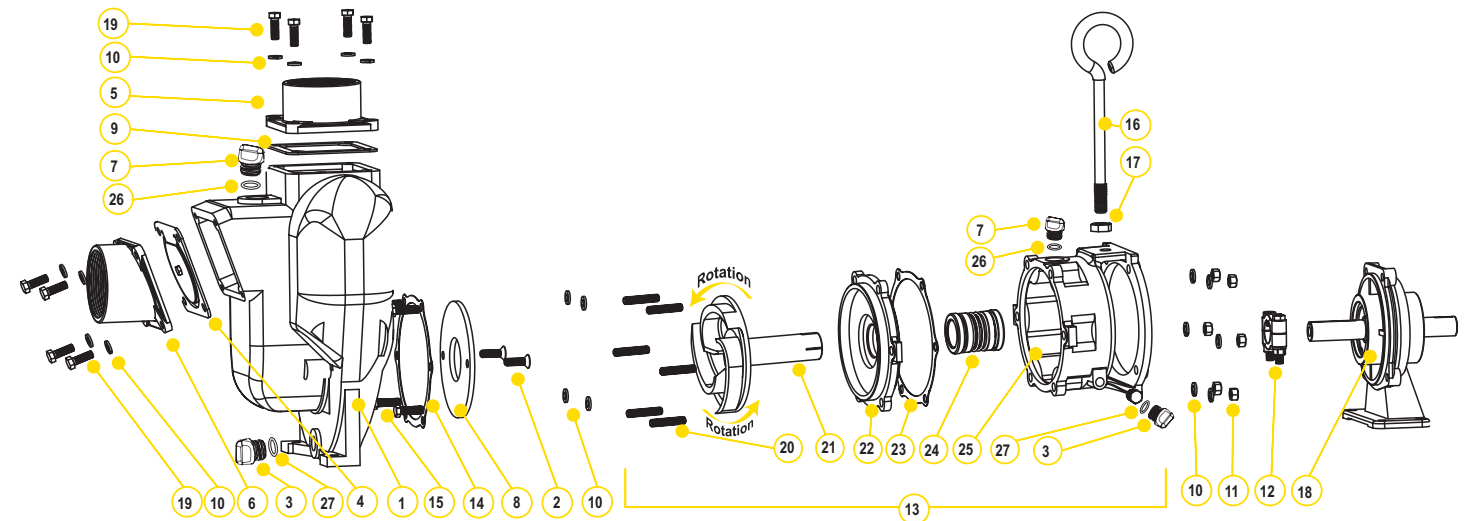

### REPLACEMENT PARTS 3" CAST IRON PUMPS

| ITEM | PART NO | DESCRIPTION                    | QTY |
|------|---------|--------------------------------|-----|
| 1    | 18001   | PUMP HOUSING                   | 1   |
| 2    | 18106   | FLAT HEAD SOCKET CAP SCREW     | 2   |
| 3    | 12777   | 1/2" PLUG                      | 2   |
| 4    | 18013   | INLET/CHECK EPDM GASKET        | 1   |
| 5    | 18008   | 3" NPT OUTLET FLANGE           | 1   |
| 6    | 18012   | 3" NPT INLET FLANGE            | 1   |
| 7    | 13777   | 3/4" PLUG                      | 2   |
| 8    | 18004   | WEAR PLATE                     | 1   |
| 9    | 18009   | EPDM OUTLET GASKET             | 1   |
| 10   | V20018  | 3/8" LOCK WASHER               | 18  |
| 11   | V20019  | 3/8" 16 SS HEX NUT             | 6   |
| 12   | 18129   | CLAMP ASSEMBLY KEYED           | 1   |
| 13   | 18200A  | WET SEAL ASSEMBLY              | 1   |
| 14   | 18021   | ADAPTER GASKET                 | 1   |
| 15   | 17704   | 3/8" -16 X 1 1/4" HHCS         | 4   |
| 16   | 18033   | HANDLE                         | 1   |
| 17   | 18034   | 5/8" -11 JAM NUT               | 1   |
| 18   | 18500   | BEARING PEDESTAL               | 1   |
| 19   | 18010SS | 3/8" - 16 X 1 1/8" HHCS        | 8   |
| 20   | 18218   | 3/8" -16 X 24 X 2 1/8" SS STUD | 6   |
| 21   | 18206   | IMPELLER                       | 1   |
| 22   | 18202A  | COVER PLATE                    | 1   |
| 23   | 18021   | ADAPTER GASKET                 | 1   |
| 24   | 15035E  | EPDM MECHANICAL SEAL ASSEMBLY  | 1   |
| 25   | 18203A  | WET SEAL RESERVOIR             | 1   |
| 26   | 13778   | O-RING                         | 2   |
| 27   | UV15163 | O-RING                         | 2   |



WARNING! DO NOT USE WITH FLAMMABLE LIQUIDS



| 3" CAST IRON WET SEAL PUMP ONLY |                                 |     |     |          |
|---------------------------------|---------------------------------|-----|-----|----------|
| PART NO                         | DESCRIPTION                     | HP  | QTY | SKID QTY |
| 301POIW                         | 3" CAST IRON WET SEAL PUMP ONLY | N/A | 1   | 8        |



| 3" CAST IRON WET SEAL PUMP BEARING PEDESTAL |  |     |     |          |
|---|--|-----|-----|----------|
| PART NO                                     | DESCRIPTION                                      | HP  | QTY | SKID QTY |
| 301PBIW                                     | 3" CAST IRON WET SEAL PUMP WITH BEARING PEDESTAL | N/A | 1   | 8        |

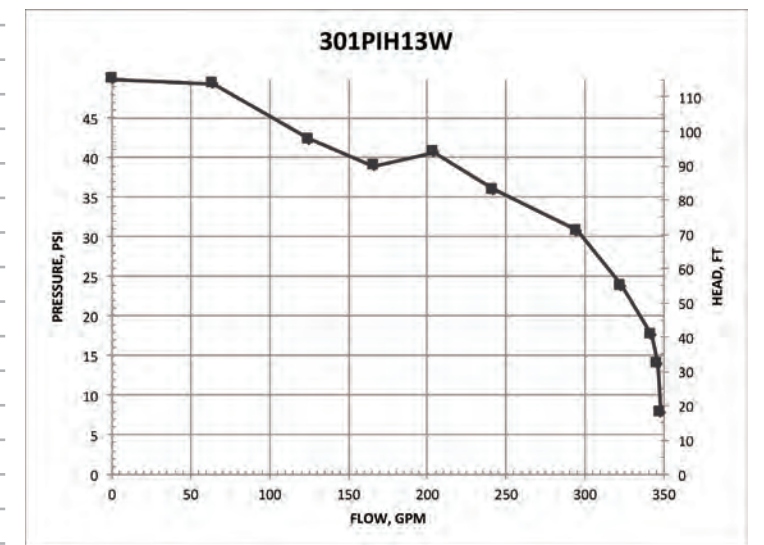



# CENTRIFUGAL PUMPS

# CENTRIFUGAL PUMPS

## 3" CAST IRON PUMPS WITH HYDRAULIC MOTORS

## 3" CAST IRON PUMPS WITH HYDRAULIC MOTORS

### FEATURES

- Cast iron construction for rugged dependable service
- Stainless steel hardware
- Replaceable inlet and outlet flanges
- Dynamically balanced impeller
- Hydraulic fluid capacity is minimum 9 gallons and maximum 13 gallons
- Open or closed system
- 21 HP motor
- Recommendation to use the motor spool control valve or a suitable equivalent. The lack of such a valve in this circuit may cause failure to the hydraulic motor and will void warranty.



### 3" CAST IRON PUMPS W/ HYDRAULIC MOTORS

| PART NO | DESCRIPTION                                | HP | QTY | SKID QTY |
|---------|--|----|-----|----------|
| 300PIHY | 3" CAST IRON PUMP W/ 21 HP HYDRAULIC MOTOR | 21 | 1   | 8        |

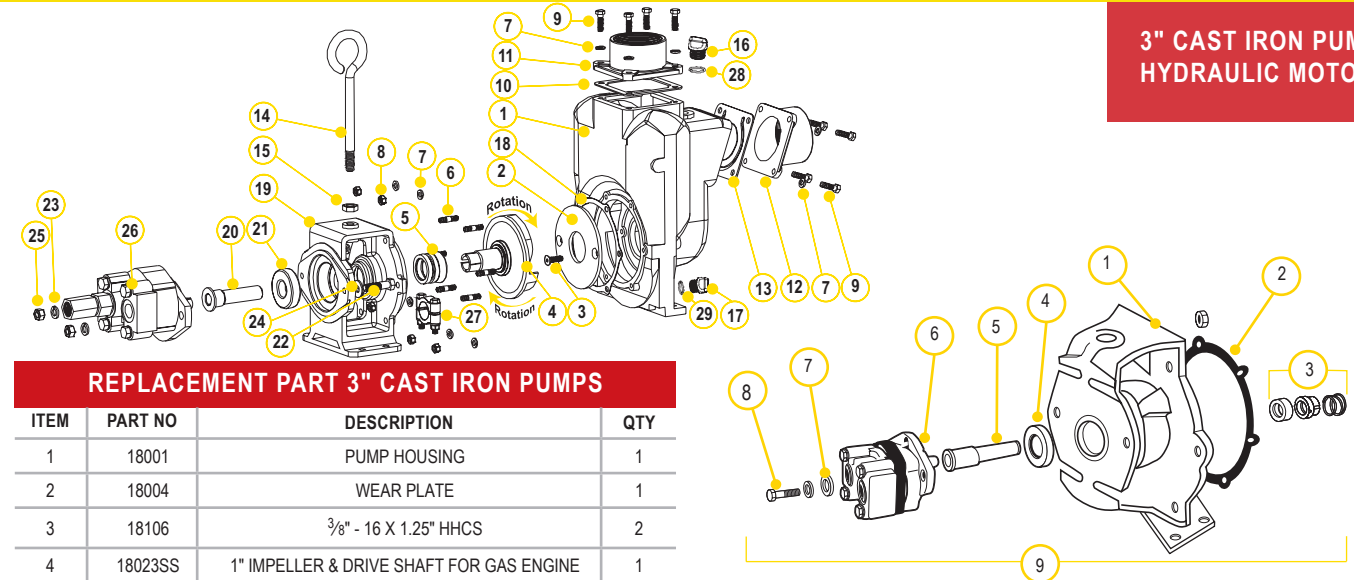

### REPLACEMENT PART 3" CAST IRON PUMPS

| ITEM | PART NO | DESCRIPTION                              | QTY |
|------|---------|--|-----|
| 1    | 18001   | PUMP HOUSING                             | 1   |
| 2    | 18004   | WEAR PLATE                               | 1   |
| 3    | 18106   | 3/8" - 16 X 1.25" HHCS                   | 2   |
| 4    | 18023SS | 1" IMPELLER & DRIVE SHAFT FOR GAS ENGINE | 1   |
| 5    | 18025   | FKM MECHANICAL SEAL                      | 1   |
| 5    | 18025SD | SEVERE DUTY SEAL                         | 1   |
| 6    | 18218   | 3/8" -16 X 24 X 2 1/8" SS STUD           | 6   |
| 7    | V20018  | 3/8" LOCK WASHER                         | 14  |
| 8    | V20019  | 3/8" 16 SS HEX NUT                       | 6   |
| 9    | 18010SS | 3/8" - 16 X 1.25" HHCS                   | 8   |
| 10   | 18009   | EPDM OUTLET GASKET                       | 1   |
| 11   | 18008   | 3" NPT OUTLET FLANGE                     | 1   |
| 12   | 18012   | 3" NPT INLET FLANGE                      | 1   |
| 13   | 18013   | INLET/CHECK EPDM GASKET                  | 1   |
| 14   | 18033   | HANDLE                                   | 1   |
| 15   | 18034   | 5/8" -11 HEX NUT                         | 1   |
| 16   | 13777   | 3/4" PLUG                                | 1   |
| 17   | 12777   | 1/2" PLUG                                | 1   |
| 18   | 18021   | ADAPTER GASKET                           | 1   |
| 19   | 18049   | HYDRAULIC MOTOR ADAPTER                  | 1   |
| 20   | 18055   | HYDRAULIC ADAPTER SHAFT                  | 1   |
| 21   | 18502   | BEARING SKF 66306-2RS1/C3                | 1   |
| 22   | 18056   | 1/2" -13 X 2" HHCS                       | 2   |
| 23   | N/A     | 1/2" SPLIT WASHER                        | 2   |
| 24   | N/A     | 1/2" FLAT WASHER                         | 2   |
| 25   | 17010   | 1/2" - 13 HEX NUT                        | 2   |
| 26   | HY1012  | UM16-45A-HX HYDRAULIC MOTOR ASSEMBLY     | 1   |
| 27   | 18029   | CLAMP ASSEMBLY UNKEYED                   | 1   |
| 28   | 13778   | O-RING                                   | 1   |
| 29   | UV15163 | O-RING                                   | 1   |
| KIT  | 18100   | REPAIR KIT (CONSIST OF 2, 3, 4, 5, 18)   | 1   |

### REPLACEMENT PARTS 3" HYDRAULIC ADAPTER

| ITEM | PART NO | DESCRIPTION                      | QTY |
|------|---------|----------------------------------|-----|
| 1    | 18049   | C-FACE HYDRAULIC MOTOR ADAPTER   | 1   |
| 2    | 18021   | GASKET ADAPTER                   | 1   |
| 3    | 18025   | SEAL ASSEMBLY                    | 1   |
| 4    | 18502   | SKF 63306-2RS1/C3 BEARING        | 1   |
| 5    | 18055   | HYDRAULIC ADAPTER SHAFT SLEEVE   | 1   |
| 6    | HY1012  | TYRONE® UM16 HYDRAULIC MOTOR     | 1   |
| 7    | N/A     | 1/2" FLAT WASHER                 | 2   |
| 8    | N/A     | 1/2" SPLIT LOCK WASHER           | 2   |
| 9    | 18056   | 1/2" - 13" X 2" HHCS BOLT        | 2   |
| 10   | 17010   | 1/2" HEX NUT                     | 2   |
| 11   | 18600   | HYDRAULIC MOTOR ADAPTER ASSEMBLY | 1   |
| KIT  | HY1001  | REPAIR KIT                       | 1   |

### HYDRAULIC MOTOR DATA

|                        |                 |
|------------------------|-----------------|
| U.S. GALLONS/REV.      | 0.0038          |
| CUBIC INCHES/REV.      | 0.878           |
| LITERS/REV.            | 0.0144          |
| MAX HYDRAULIC PRESSURE | 3000 PSI        |
| MIN HYDRAULIC PRESSURE | 600 PSI         |
| INLET PORT             | 1-1/16-12UN-2B  |
| OUTLET PORT            | 1-5/16-12UN-2B  |
| MINIMUM GPM REQUIRED   | 9 GPM 2370 RPM  |
| MAXIMUM GPM REQUIRED   | 13 GPM 3450 RPM |
| IDEAL GPM REQUIRED     | 9 GPM 3600 RPM  |

### CONNECTION INFORMATION

|        |          |
|--------|----------|
| INLET  | "A" PORT |
| OUTLET | "B" PORT |

SUPPLIED CHECK VALVE IS TO ENSURE PROPER ROTATION OF THE BANJO PUMP. PLACE CHECK VALVE IN OUTLET PORT (MARKED "B") FOR PROPER RIGHT HAND ROTATION. IT IS RECOMMENDED THAT A MINIMUM 1/2" INLET LINE & A MINIMUM 1" OUTLET LINE BE USED. THE OUTLET PORT MUST BE CONNECTED DIRECTLY BACK TO THE HYDRAULIC FLUID RESERVOIR & NOT TO ANY VALVING, REGULATORS OR FLOW DIVERTERS. THE OUTLET PORT/RETURN LINE BACK PRESSURE MUST NOT EXCEED 250 PSI.

### SPOOL VALVE INFORMATION

|                          |                            |
|--------------------------|----------------------------|
| REQUIRED OUTLET FLOW     | MIN 9 GPM / MAX 13 GPM     |
| REQUIRED SYSTEM PRESSURE | MIN 600 PSI / MAX 3000 PSI |

### SPOOL VALVE ASSEMBLY DIAGRAM

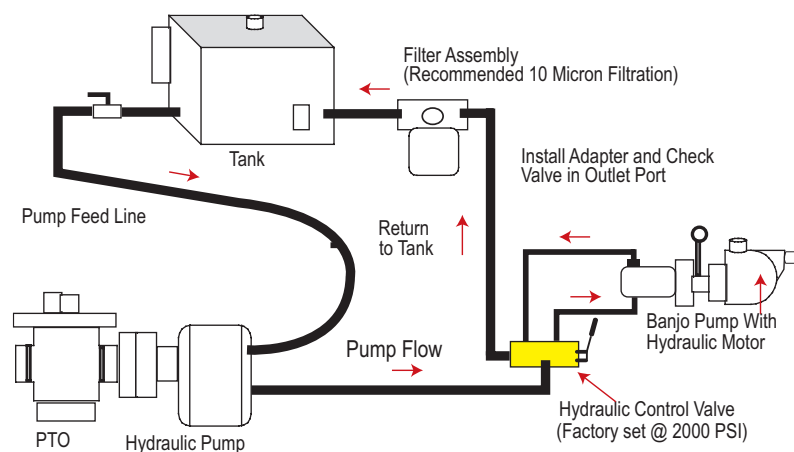

### HYDRAULIC MOTOR SPOOL VALVE

| PART NO | DESCRIPTION                 | HP  | QTY |
|---------|-----------------------------|-----|-----|
| HSV1000 | HYDRAULIC MOTOR SPOOL VALVE | N/A | 1   |

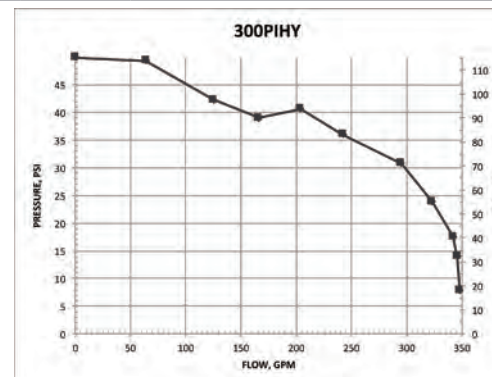

WARNING! DO NOT RUN PUMP DRY, RESTRICT OR REDUCE PORT SIZES OR DEAD HEAD PUMP



WARNING! DO NOT USE WITH FLAMMABLE LIQUIDS

## 3" 333 SERIES CAST IRON PUMPS

POWERED by **HONDA**



### FEATURES

- Cast iron construction for rugged dependable service
- Carbon ceramic seal with stainless steel cup and spring with FKM rubber
- Replaceable inlet and outlet flanges
- Dynamically balanced impeller
- Heavy duty slinger seal on motor shaft
- Large weep holes between pump end and engine
- Pedestal pump for long coupling to electric motor
- Due to weight and size of pumps, Banjo ships these by truck only.
- Engine warranty service available at authorized dealers



### 333 SERIES CAST IRON PUMPS W/GAS ENGINES

| PART NO  | DESCRIPTION   | HP | QTY | SKID QTY |
|----------|---|----|-----|----------|
| 333PIH13 | 3" CAST IRON PUMP W/13 HP HONDA® ENGINE W/ ELECTRIC START & PULL ROPE | 13 | 1   | 1        |

### 333 SERIES CAST IRON PUMP ONLYS

| PART NO  | DESCRIPTION   | HP  | QTY | SKID QTY |
|----------|---|-----|-----|----------|
| 333POI   | 3" CAST IRON PUMP ONLY W/1" SHAFT & 5 VANE IMPELLER UNASSEMBLED | N/A | 1   | 6        |
| 333POICF | 3" CAST IRON PUMP ONLY W/ ELECTRIC MOTOR ADAPTER                | N/A | 1   | 6        |

### 333 SERIES CAST IRON BEARING PEDESTAL

| PART NO | DESCRIPTION                               | HP  | QTY | SKID QTY |
|---------|---|-----|-----|----------|
| 333PBI  | 3" CAST IRON BEARING PEDESTAL W/ 1" SHAFT | N/A | 1   | 6        |

### 333 SERIES CAST IRON HYDRAULIC PUMPS

| PART NO  | DESCRIPTION  | HP | QTY | SKID QTY |
|----------|--|----|-----|----------|
| 333PIE15 | 3" CAST IRON PUMP W/15 HP THREE PHASE ELECTRIC MOTOR | 15 | 1   | 1        |

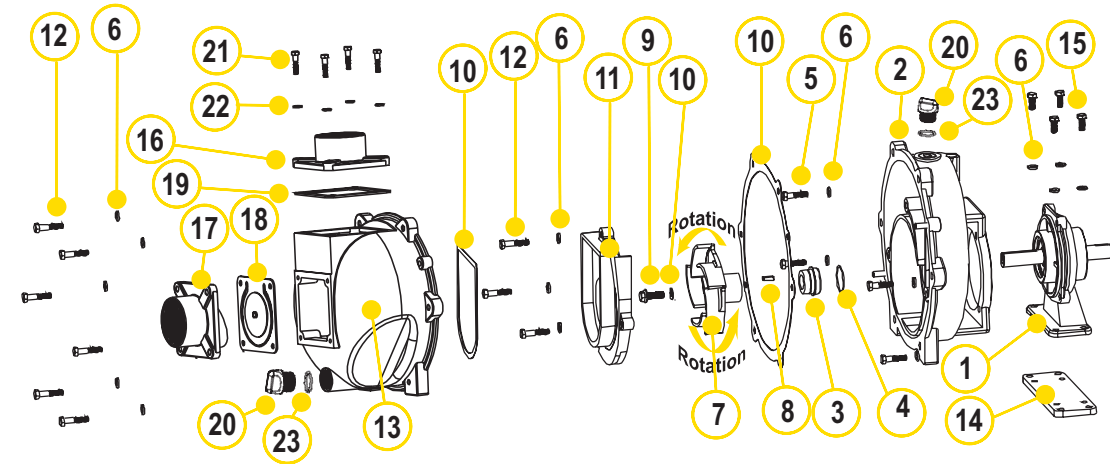

### REPLACEMENT PARTS 3" CAST IRON PUMPS

| ITEM | PART NO | DESCRIPTION  | QTY |
|------|---------|--|-----|
| N/S  | 16099   | IMPELLER REMOVAL BOLT  | 1   |
| 1    | 18500   | BEARING PEDESTAL (333PBI)  | 1   |
| 2    | 16704   | REAR BRACKET   | 1   |
| 3    | 16713   | MECHANICAL SEAL  | 1   |
| 4    | 16710   | O-RING   | 1   |
| 5    | 17704   | 3/8" - 16 X 1.25" SS CAP SCREW (333PBI)                            | 4   |
| 6    | V20018  | 3/8" SS LOCK WASHER  | 17  |
| 7    | 16773   | 3" IMPELLER (333PBI)   | 1   |
| 7    | 16774   | 3" IMPELLER (333PIH13 & 333POI)                                    | 1   |
| 7    | 16774A  | 3" IMPELLER (333PIE15)   | 1   |
| 8    | 16901   | 1/4" SQ. 3/4" KEY STOCK  | 1   |
| 9    | 16765   | IMPELLER BOLT (333PBI)   | 1   |
| 9    | 13765   | IMPELLER BOLT (333PIH13)   | 1   |
| 10   | 16019   | GASKET SET   | 1   |
| 11   | 16702   | VOLUTE   | 1   |
| 12   | N/A     | 3/8" - 16 X 1.75" SS BOLT  | 9   |
| 13   | 16733   | BODY   | 1   |
| 14   | 18511   | ADAPTER PLATE (333PBI)   | 1   |
| 15   | 18512   | 3/8" - 16 X 0.875" SS HHCS (333PBI)                                | 4   |
| N/S  | 16751   | BRACKET SHIM SET   | 1   |
| N/S  | 16752   | IMPELLER SHIM  | 1   |
| N/S  | 18033   | HANDLE   | 1   |
| N/S  | 18034   | 5/8" SS JAM NUT  | 1   |
| 16   | 16001   | 3" NPT OUTLET FLANGE   | 1   |
| 17   | 16003   | 3" NPT INLET FLANGE  | 1   |
| 18   | 16706   | FKM INLET GASKET W/ CHECK  | 1   |
| 19   | 16011   | FKM OUTLET GASKET  | 1   |
| 20   | 13777   | 3/4" PLUG  | 2   |
| 21   | 18027   | 3/8" - 16 X 1.50" HHCS (333PIH13)                                  | 8   |
| 22   | V20018  | 3/8" SS LOCK WASHER  | 8   |
| 23   | 13778   | O-RING   | 2   |
| NS   | 16100   | REPAIR KIT (CONSIST OF ITEMS 3, 4, 8, 10, 16751, 16752, 16099, 23) | 1   |

### REPLACEMENT PARTS 333PIE15

| ITEM | PART NO | DESCRIPTION                   | QTY |
|------|---------|-------------------------------|-----|
| N/S  | 16099   | IMPELLER REMOVAL BOLT         | 1   |
| 2    | 16704A  | REAR BRACKET W/C-FACE ADAPTER | 1   |
| 3    | 15025   | MECHANICAL SEAL               | 1   |
| 6    | V20018  | 3/8" SS LOCK WASHER           | 8   |
| 7    | N/A     | 3" IMPELLER - 5 VANE          | 1   |
| 8    | N/A     | 1/4" SQ. 3/4" KEY STOCK       | 1   |
| 9    | 16765   | 7/16-20 1/4" HFS              | 1   |
| 10   | 16019   | GASKET SET                    | 1   |
| 11   | 16702   | VOLUTE                        | 1   |
| 12   | N/A     | 3/8" - 16 X 1.75" SS BOLT     | 9   |
| 13   | 16733   | BODY                          | 1   |
| N/S  | 16751   | BRACKET SHIM SET              | 1   |
| N/S  | 16752   | IMPELLER SHIM                 | 1   |
| N/S  | 18033   | HANDLE                        | 1   |
| N/S  | 18034   | 5/8" SS JAM NUT               | 1   |
| 16   | 16001   | OUTLET FLANGE                 | 1   |
| 17   | 16003   | INLET FLANGE                  | 1   |
| 18   | 16706   | FKM INLET GASKET W/ CHECK     | 1   |
| 19   | 16011   | FKM OUTLET GASKET             | 1   |
| 20   | 13777   | 3/4" PLUG                     | 2   |
| 21   | 18027   | 3/8" - 16 X 1.50" HHCS        | 8   |
| 22   | V20018  | 3/8" SS LOCK WASHER           | 4   |
| 23   | 13778   | O-RING                        | 2   |

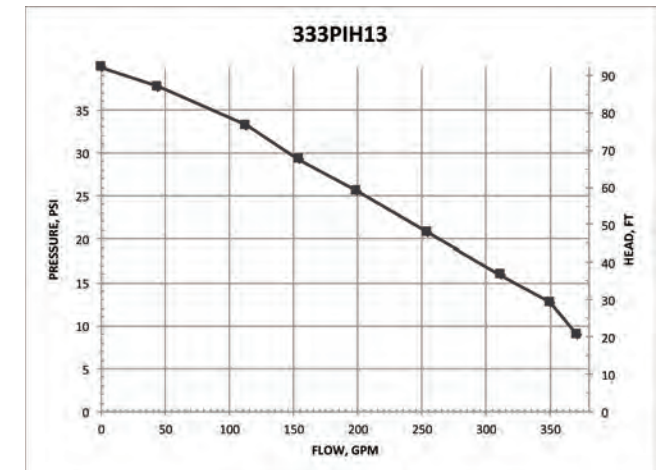

WARNING! DO NOT RUN PUMP DRY, RESTRICT OR REDUCE PORT SIZES OR DEAD HEAD PUMP



WARNING! DO NOT USE WITH FLAMMABLE LIQUIDS



## 3" M332 SERIES CAST IRON MANIFOLD WET SEAL PUMPS

## 3" M332 SERIES CAST IRON MANIFOLD WET SEAL PUMPS

### FEATURES

- Run dry capability
- Cast iron construction for rugged dependable service
- Carbon ceramic seal with stainless steel cup and spring with EPDM rubber
- Replaceable inlet and outlet flanges
- Dynamically balanced impeller
- Heavy duty slinger seal on motor shaft
- Due to weight and size of pumps, Banjo ships these by truck only.
- Engine warranty service available at authorized dealers
- See pages 43-49 on manifold fittings for easy plumbing.



**M332 SERIES CAST IRON WET SEAL PUMPS W/GAS ENGINES**

| PART NO    | DESCRIPTION  | HP | QTY | SKID QTY |
|------------|--|----|-----|----------|
| M332PIH13W | 3" MANIFOLD CAST IRON WET SEAL PUMP W/13 HP HONDA® ENGINE W/ELECTRIC START & PULL ROPE | 13 | 1   | 6        |



**M332 SERIES CAST IRON WET SEAL PUMPS W/ELECTRIC MOTORS**

| PART NO     | DESCRIPTION  | HP | QTY | SKID QTY |
|-------------|--|----|-----|----------|
| M332PIE10W  | 3" MANIFOLD CAST IRON WET SEAL PUMP W/10HP THREE PHASE ELECTRIC MOTOR  | 10 | 1   | 3        |
| M332PIE101W | 3" MANIFOLD CAST IRON WET SEAL PUMP W/10HP SINGLE PHASE ELECTRIC MOTOR | 10 | 1   | 1        |

**M332 SERIES CAST IRON WET SEAL PUMP ONLY**

| PART NO  | DESCRIPTION                              | HP  | QTY | SKID QTY |
|----------|--|-----|-----|----------|
| M332POIW | 3" MANIFOLD CAST IRON WET SEAL PUMP ONLY | N/A | 1   | 6        |

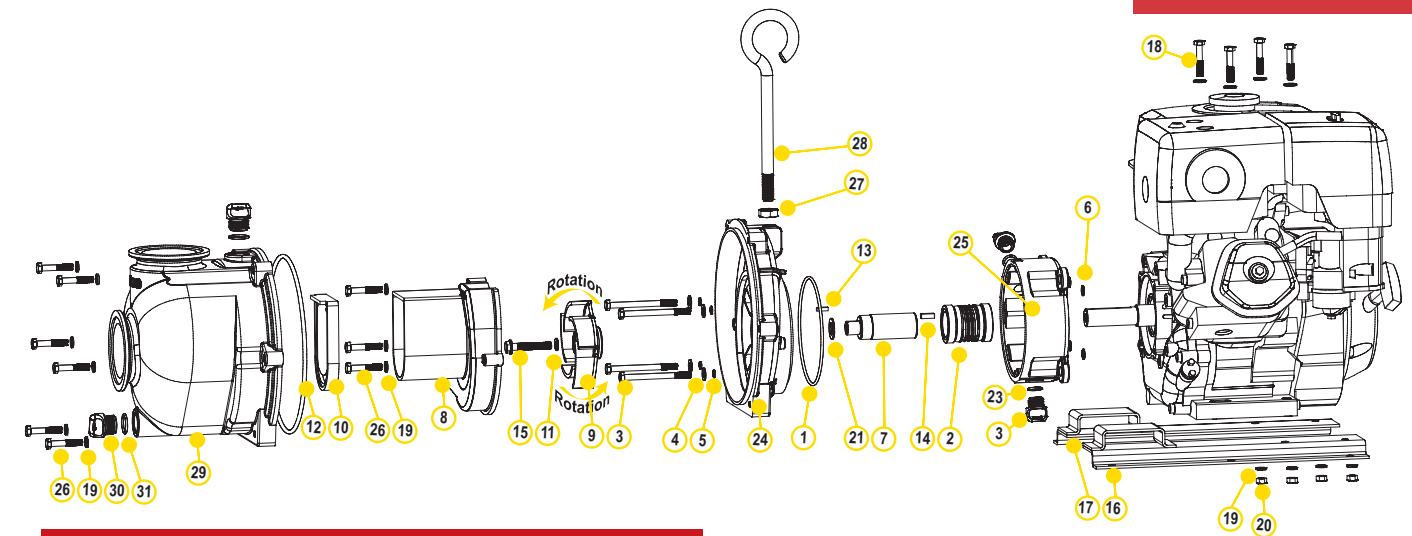

**REPLACEMENT PARTS M332 SERIES CAST IRON PUMPS**

| ITEM | PART NO    | DESCRIPTION                   | QTY |
|------|------------|-------------------------------|-----|
| 1    | 13719      | O-RING                        | 1   |
| 2    | 15035E     | EPDM MECHANICAL SEAL ASSEMBLY | 1   |
| 3    | 13034      | 5/16" - 24 X 3/4" HHCS        | 1   |
| 4    | 12901      | 5/16" FLAT WASHER             | 4   |
| 5    | 12717      | O-RING FOR BRACKET SCREW      | 8   |
| 6    | 12709      | O-RING                        | 4   |
| 7    | 13055      | ADAPTER SHAFT                 | 4   |
| 8    | 19702      | VOLUTE                        | 1   |
| 9    | 19772SS    | 5 VANE IMPELLER               | 1   |
| 9    | 15772      | IMPELLER (M332PBIW)           | 1   |
| 10   | 12705      | CHECK VALVE                   | 1   |
| 11   | A204       | O-RING                        | 1   |
| 12   | 12719A     | BODY O-RING                   | 1   |
| 13   | 12902A     | IMPELLER KEY                  | 1   |
| 14   | 16901      | 1/4" SQ X 3/4" KEY STOCK      | 1   |
| 15   | 13766      | 3/8" - 24 X 2 1/4" HFS        | 1   |
| 16   | N/A        | Z-RAIL                        | 1   |
| 17   | N/A        | Z-RAIL                        | 1   |
| 18   | N/A        | 5/16" - 18 X 1 1/2" HHCS      | 4   |
| 19   | V10118     | 5/16" LOCK WASHER             | 13  |
| 20   | V10119     | 5/16" HEX NUT                 | 4   |
| 21   | CV10175    | GASKET                        | 2   |
| 22   | 12777      | 1/2" PLUG                     | 2   |
| 23   | UV15163    | O-RING                        | 2   |
| 24   | 19703W     | REAR BRACKET                  | 1   |
| 25   | 19201W     | WET SEAL RESERVOIR            | 1   |
| 26   | 12715A     | 5/16" - 24 X 1 3/4" HHCS      | 9   |
| 27   | 18034      | 5/8"-11 JAM NUT               | 1   |
| 28   | 18033      | PUMP HANDLE                   | 1   |
| 29   | M19712X    | PUMP BODY                     | 1   |
| 30   | 13777      | 3/4" PLUG                     | 2   |
| 31   | 13778      | O-RING                        | 2   |
| NS   | BEM10-100  | 10 HP, 215TC, 3 PH, 1" SHAFT  | 1   |
| NS   | BEM101-100 | 10HP, 215TC, 1 PH, 1" SHAFT   | 1   |



**WARNING! DO NOT USE WITH FLAMMABLE LIQUIDS**

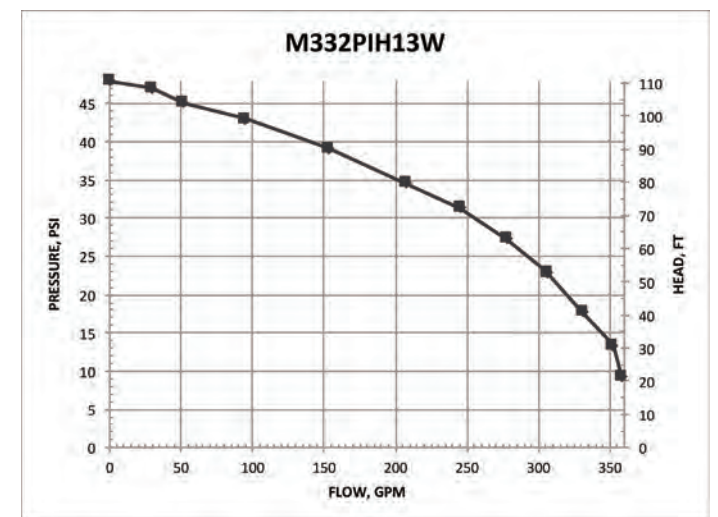

# CENTRIFUGAL PUMPS

## 3" M332 SERIES CAST IRON MANIFOLD WET SEAL PUMPS WITH HYDRAULIC MOTORS

### FEATURES

- Run dry capability
- Cast iron construction for rugged dependable service
- Carbon ceramic seal with stainless steel cup and spring with EPDM rubber
- Replaceable inlet and outlet flanges
- Dynamically balanced impeller
- Heavy duty slinger seal on motor shaft
- Hydraulic fluid capacity is minimum 9 gallons and maximum 13 gallons
- Open or closed system
- 3600 R.P.M.
- Recommendation to use the motor spool control valve or a suitable equivalent. The lack of such a valve in this circuit may cause failure to the hydraulic motor and will void warranty.
- See pages 43-49 on manifold fittings for easy plumbing.



| M332 SERIES CAST IRON MANIFOLD WET SEAL PUMPS W/O HYDRAULIC MOTOR |  |     |     |          |
|---|--|-----|-----|----------|
| PART NO   | DESCRIPTION  | HP  | QTY | SKID QTY |
| M332PIHYW   | 3" MANIFOLD CAST IRON WET SEAL PUMP W/ HYDRAULIC MOTOR | 21  | 1   | 8        |
| M332PIHAW   | 3" MANIFOLD CI WET SEAL PUMP WITHOUT HYDRAULIC MOTOR   | N/A | 1   | 1        |

### SPOOL VALVE ASSEMBLY DIAGRAM

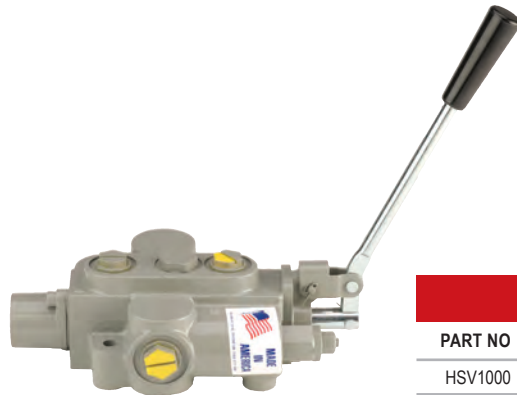
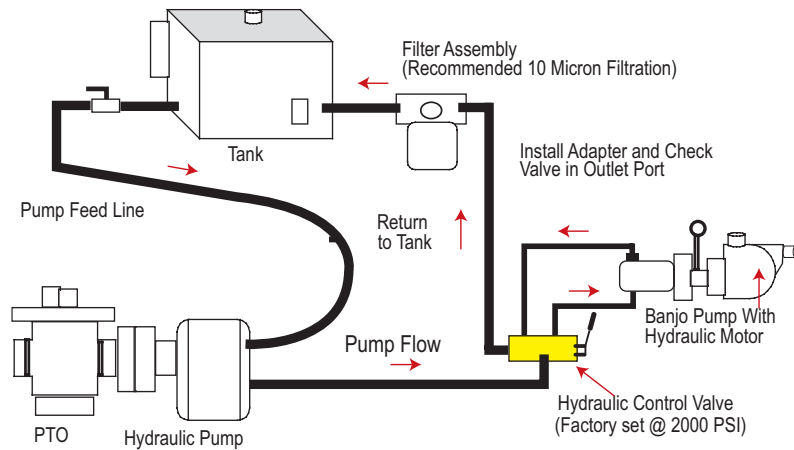

| HYDRAULIC MOTOR SPOOL VALVE |                             |     |     |  |
|-----------------------------|-----------------------------|-----|-----|--|
| PART NO                     | DESCRIPTION                 | HP  | QTY |  |
| HSV1000                     | HYDRAULIC MOTOR SPOOL VALVE | N/A | 1   |  |

# CENTRIFUGAL PUMPS

## 3" M332 SERIES CAST IRON MANIFOLD WET SEAL PUMPS WITH HYDRAULIC MOTORS

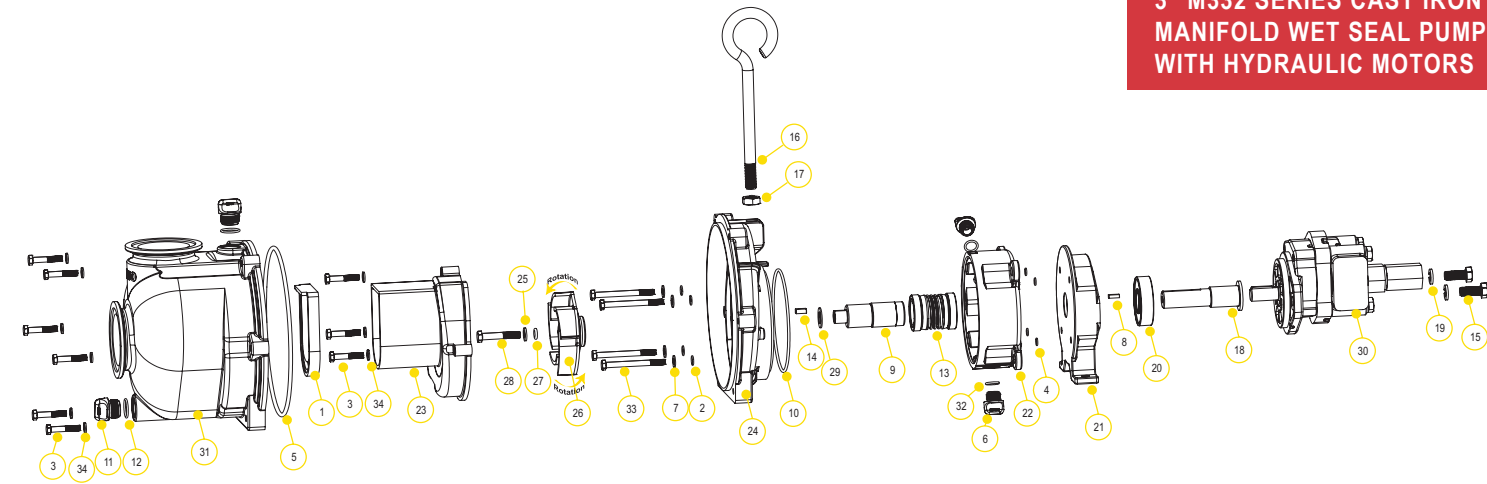

### REPLACEMENT PARTS M332 SERIES CAST IRON PUMPS

| ITEM | PART NO | DESCRIPTION                   | QTY |
|------|---------|-------------------------------|-----|
| 1    | 12705   | CHECK VALVE                   | 1   |
| 2    | 12709   | O-RING                        | 4   |
| 3    | 12715A  | SS BRACKET SCREWS-            | 9   |
| 4    | 12717   | O-RING FOR SCREW HEAD         | 4   |
| 5    | 12719A  | BODY O-RING                   | 1   |
| 6    | 12777   | 1/2" PLUG                     | 2   |
| 7    | 12901   | SS REAR BRACKET WASHER        | 4   |
| 8    | 12902A  | IMPELLER KEY                  | 1   |
| 9    | 13055   | ADAPTER SHAFT                 | 1   |
| 10   | 13719   | O-RING                        | 1   |
| 11   | 13777   | 3/4" PLUG                     | 2   |
| 12   | 13778   | O-RING                        | 2   |
| 13   | 15035E  | EPDM MECHANICAL SEAL ASSEMBLY | 1   |
| 14   | 16901   | 1/2" SQ. 3/4" KEY STOCK       | 1   |
| 15   | N/A     | BOLT                          | 2   |
| 16   | 18033   | HANDLE                        | 1   |
| 17   | 18034   | 5/8" SS JAM NUT               | 1   |
| 18   | 18055H  | HYDRAULIC MOTOR ADAPTER SHAFT | 1   |
| 19   | N/A     | 1/2" SPLIT LOCK WASHER        | 2   |
| 20   | 18502   | SKF 63306-2RS1/C3 BEARING     | 1   |
| 21   | 19001H  | RESERVOIR BACKING PLATE       | 1   |
| 22   | 19201W  | WET SEAL RESERVOIR            | 1   |
| 23   | 19702   | VOLUTE                        | 1   |
| 24   | 19703W  | REAR BRACKET                  | 1   |
| 25   | N/A     | 3/8" FLAT WASHER              | 1   |
| 26   | 19772SS | 5 VANE IMPELLER               | 1   |
| 27   | A204    | O-RING                        | 1   |
| 28   | BF311   | 3/8" - 16 X 3" HHCS           | 1   |
| 29   | CV10175 | GASKET                        | 1   |
| 30   | HY1012  | TYRONE® UM16 HYDRAULIC MOTOR  | 1   |
| 31   | M19712X | PUMP BODY                     | 1   |
| 32   | UV15163 | PRIME/DRAIN PLUG O-RING       | 2   |
| 33   | V10118  | 5/16" SS LOCK WASHER          | 4   |
| 34   | V10117  | 5/16" X 3 1/2" SS BODY BOLT   | 9   |

### HYDRAULIC MOTOR DATA

|                        |                 |
|------------------------|-----------------|
| U.S. GALLONS/REV.      | 0.0038          |
| CUBIC INCHES/REV.      | 0.878           |
| LITERS/REV.            | 0.0144          |
| MAX HYDRAULIC PRESSURE | 3000 PSI        |
| MIN HYDRAULIC PRESSURE | 600 PSI         |
| INLET PORT             | 1-1/16-12UN-2B  |
| OUTLET PORT            | 1-5/16-12UN-2B  |
| MINIMUM GPM REQUIRED   | 9 GPM 2370 RPM  |
| MAXIMUM GPM REQUIRED   | 13 GPM 3450 RPM |
| IDEAL GPM REQUIRED     | 9 GPM 3600 RPM  |

### CONNECTION INFORMATION

|        |          |
|--------|----------|
| INLET  | "A" PORT |
| OUTLET | "B" PORT |

SUPPLIED CHECK VALVE IS TO ENSURE PROPER ROTATION OF THE BANJO PUMP. PLACE CHECK VALVE IN OUTLET PORT (MARKED "B") FOR PROPER RIGHT HAND ROTATION. IT IS RECOMMENDED THAT A MINIMUM 3/4" INLET LINE & A MINIMUM 1" OUTLET LINE BE USED. THE OUTLET PORT MUST BE CONNECTED DIRECTLY BACK TO THE HYDRAULIC FLUID RESERVOIR & NOT TO ANY VALVING, REGULATORS OR FLOW DIVERTERS. THE OUTLET PORT/RETURN LINE BACK PRESSURE MUST NOT EXCEED 250 PSI.

### SPOOL VALVE INFORMATION

|                          |                            |
|--------------------------|----------------------------|
| REQUIRED OUTLET FLOW     | MIN 9 GPM / MAX 13 GPM     |
| REQUIRED SYSTEM PRESSURE | MIN 600 PSI / MAX 3000 PSI |

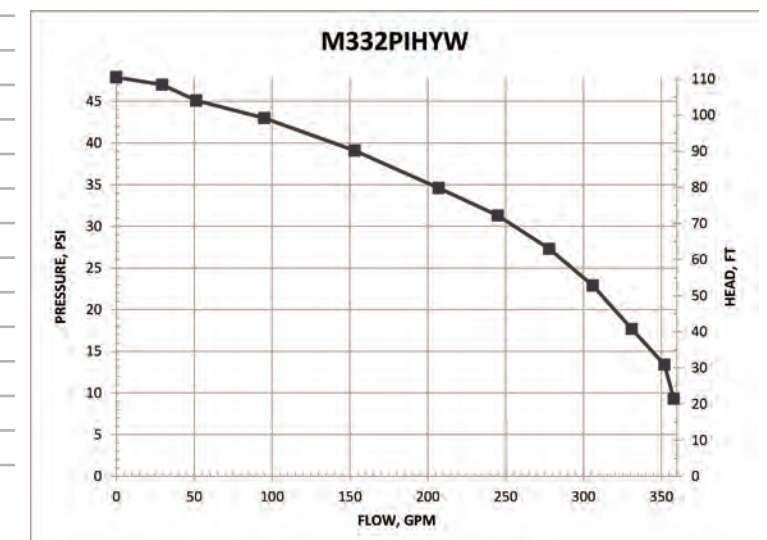

WARNING! DO NOT USE WITH FLAMMABLE LIQUIDS



## 4" 444 SERIES CAST IRON PUMPS

## 4" 444 SERIES CAST IRON PUMPS

### FEATURES

- Cast iron construction for rugged dependable service
- Carbon ceramic seal with stainless steel cup and spring with FKM rubber
- Replaceable inlet and outlet flanges
- Dynamically balanced impeller
- Heavy duty slinger seal on motor shaft
- Large weep holes between pump end and engine
- Recommendation for 444POI: use with 10 pound per gallon material or more
- Due to weight and size of pumps, Banjo ships these by truck only.
- Engine warranty service available at authorized dealers



### 444 SERIES CAST IRON PUMPS W/GAS ENGINES

| PART NO  | DESCRIPTION                             | HP | QTY | SKID QTY |
|----------|---|----|-----|----------|
| 444PIH24 | 4" CAST IRON PUMP W/24 HP HONDA® ENGINE | 24 | 1   | 1        |



### 444 SERIES CAST IRON PUMP BEARING PEDESTAL

| PART NO | DESCRIPTION  | HP  | QTY | SKID QTY |
|---------|--|-----|-----|----------|
| 444PBI  | 4" CAST IRON PUMP W/BEARING PEDESTAL W/ 1" SHAFT & 5 VANE IMPELLER | N/A | 1   | 6        |



### 444 SERIES CAST IRON PUMP ONLYS

| PART NO | DESCRIPTION   | HP  | QTY | SKID QTY |
|---------|---|-----|-----|----------|
| 444POI  | 4" CAST IRON PUMP ONLY W/ 1 1/2" X 3 1/2" SHAFT & 6 VANE IMPELLER UNASSEMBLED | N/A | 1   | 6        |

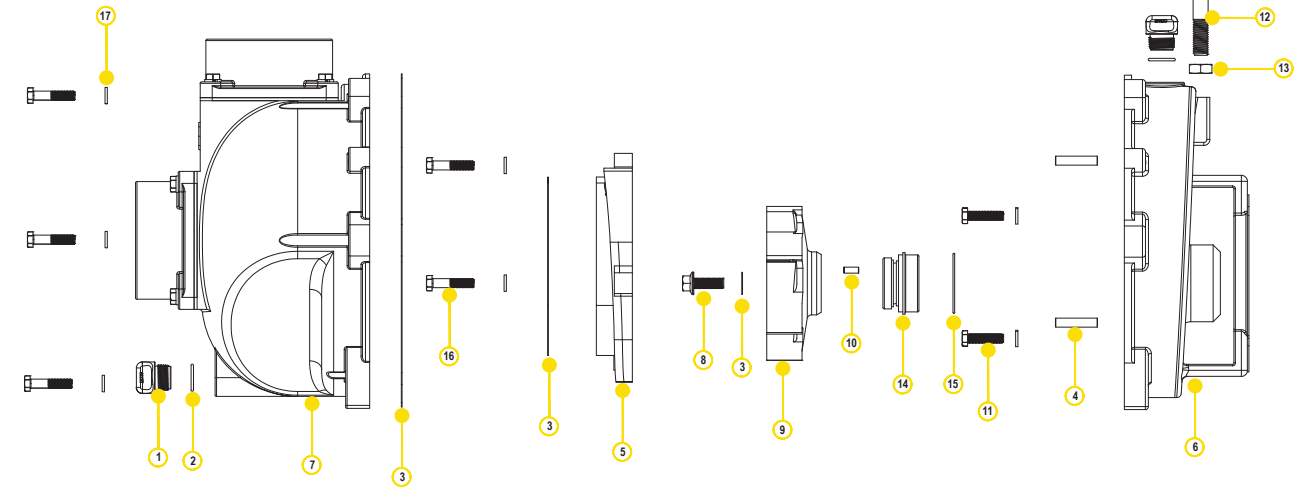

### REPLACEMENT PARTS 4" CAST IRON PUMPS

| ITEM | PART NO | DESCRIPTION              | QTY |
|------|---------|--------------------------|-----|
| 1    | 13777   | 3/4" PLUG                | 2   |
| 2    | 13778   | O-RING                   | 2   |
| 3    | 16019   | GASKET                   | 1   |
| 4    | N/A     | 3/8" X 1 1/4" DOWELL PIN | 2   |
| 5    | 16702   | VOLUTE                   | 1   |
| 6    | 16707   | REAR BRACKET             | 1   |
| 7    | 16712   | BODY                     | 1   |
| 8    | 16765   | IMPELLER BOLT            | 1   |
| 9    | 16775   | 4" IMPELLER              | 1   |
| 10   | 16901   | 1/4" SQ. 3/4" KEY STOCK  | 1   |
| 11   | 18027   | 3/8" - 16 X 1.50" HHCS   | 4   |
| 12   | 18033   | HANDLE                   | 1   |
| 13   | 18034   | 5/8" SS JAM NUT          | 1   |
| 14   | 18435   | MECHANICAL SEAL          | 1   |
| 15   | V10264  | O-RING                   | 1   |
| 16   | N/A     | 3/8"-16 X 1 1/4" HHCS    | 9   |
| 17   | V20018  | 3/8" SS LOCK WASHER      | 13  |

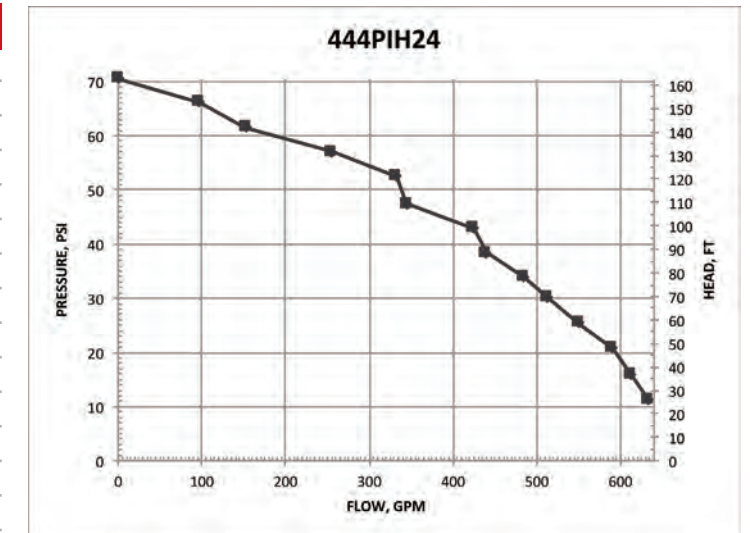

**WARNING! DO NOT RUN PUMP DRY, RESTRICT OR REDUCE PORT SIZES OR DEAD HEAD PUMP**



**WARNING! DO NOT USE WITH FLAMMABLE LIQUIDS**

**Note:** Please see repair parts list for 444PBI on our website.

## 2" STAINLESS STEEL PUMPS

### FEATURES

- ALL FKM SEALS
- 316 stainless steel housing and wettable internal components including impeller, sleeve, wear plate and fasteners
- Carbon ceramic seal with 316 stainless steel cup and spring with FKM elastomer
- Replaceable inlet and outlet flanges
- Dynamically balanced impeller
- Pump only packs complete and ready for attachment to gasoline engine
- Pedestal pump for long coupling to electric motor
- Recommendation for 5/8" shaft: 56C frame size, 3 HP, 3450 RPM & 5" max impeller for close coupling to electric motors
- Recommendation for 7/8" shaft: 145TC frame size, 3 HP, 3450 RPM & 5" max impeller for close coupling to electric motors
- Engine warranty service available at authorized dealers
- Due to weight and size of pumps, Banjo ships these by truck only.



WARNING! DO NOT RUN PUMP DRY, RESTRICT OR REDUCE PORT SIZES OR DEAD HEAD PUMP



WARNING! DO NOT USE WITH FLAMMABLE LIQUIDS



### 2" STAINLESS STEEL PUMPS W/GAS ENGINES

| PART NO   | DESCRIPTION   | HP  | QTY | SKID QTY |
|-----------|---|-----|-----|----------|
| 200PH5-SS | 2" SS PUMP W/5.5 HP HONDA® ENGINE W/ PULL ROPE ONLY | 5.5 | 1   | 8        |

### 2" STAINLESS STEEL PUMP ONLY

| PART NO  | DESCRIPTION                          | HP  | QTY | SKID QTY |
|----------|--------------------------------------|-----|-----|----------|
| 200PO-SS | 2" SS PUMP ONLY W/ 3/4" SHAFT SLEEVE | N/A | 1   | 27       |

### 2" STAINLESS STEEL C-FACE PUMPS

| PART NO      | DESCRIPTION                            | HP  | QTY | SKID QTY |
|--------------|--|-----|-----|----------|
| 200POSSCF5/8 | 2" SS C-FACE PUMP W/ 5/8" SHAFT SLEEVE | N/A | 1   | 18       |

### 2" STAINLESS STEEL BEARING PEDESTAL

| PART NO  | DESCRIPTION                                    | HP  | QTY | SKID QTY |
|----------|--|-----|-----|----------|
| 200PB-SS | 2" SS BEARING PEDESTAL W/ 3/4" STRAIGHT SHAFT* | N/A | 1   | 18       |

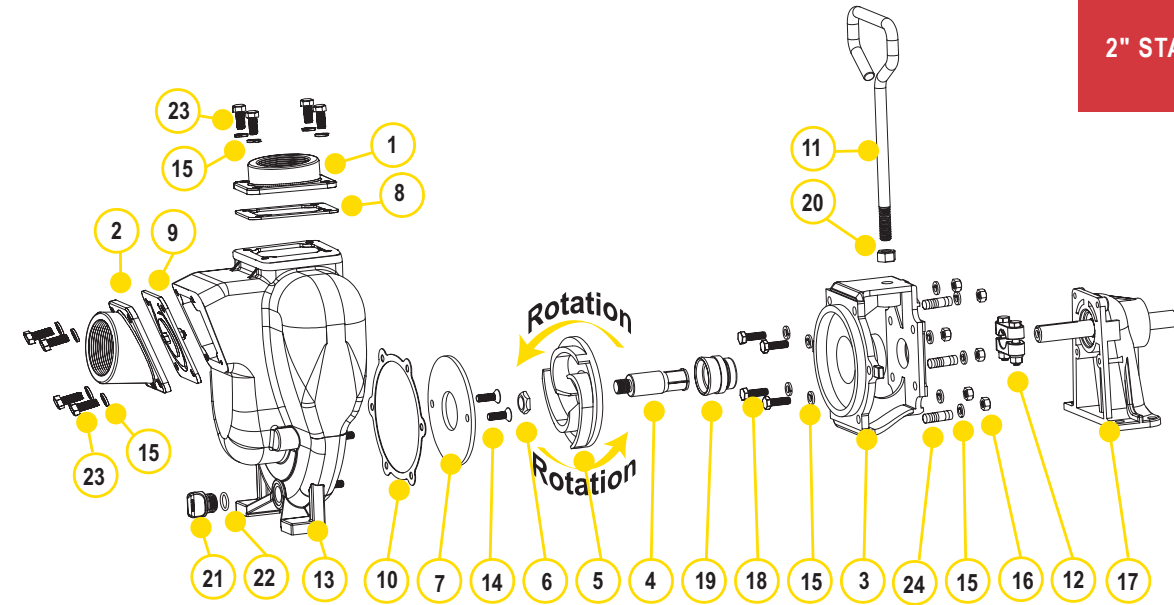

### REPLACEMENT PARTS 2" STAINLESS STEEL PUMPS

| ITEM | PART NO  | DESCRIPTION                                 | QTY |
|------|----------|---|-----|
| 1    | 17000SS  | 2" NPT SS OUTLET FLANGE                     | 1   |
| 2    | 17002SS  | 2" NPT SS INLET FLANGE                      | 1   |
| 3    | 17004SS  | SS ADAPTER FOR GAS ENGINE                   | 1   |
| 3    | 17046SS  | CF ADAPTER FOR ELECTRIC MOTOR               | 1   |
| 4    | 17005    | 5/8" SS SLEEVE DRIVE                        | 1   |
| 4    | 17006    | 3/4" SS SLEEVE DRIVE                        | 1   |
| 4    | 17007    | 7/8" SS SLEEVE DRIVE                        | 1   |
| 5    | 17008SS  | SS IMPELLER                                 | 1   |
| 5    | N/A      | 4.1" SS IMPELLER                            | 1   |
| 5    | N/A      | 4.6" SS IMPELLER                            | 1   |
| 6    | 17009B   | 5/8" IMPELLER NUT                           | 1   |
| 7    | 17011SS  | SS WEAR PLATE                               | 1   |
| 8    | 17014    | FKM OUTLET GASKET                           | 1   |
| 9    | 17017    | FKM CHECK VALVE ASSEMBLY GASKET             | 1   |
| 10   | 17018    | ADAPTER GASKET                              | 1   |
| 11   | 15022    | HANDLE                                      | 1   |
| 12   | 17023    | 5/8" CLAMP, 3/4" SS SHAFT (OLD STYLE)       | 1   |
| 12   | 17123    | 5/8" CLAMP, 3/4" SS SHAFT (KEYED CLAMP)     | 1   |
| 12   | 17024    | 7/8" CLAMP, 3/4" SS SHAFT                   | 1   |
| 13   | 17026SS  | SS PUMP HOUSING                             | 1   |
| 14   | 17130SS  | 5/16-18 X 1.00" FHSCS, 316 SS               | 2   |
| 15   | V10118   | 5/16" LOCK WASHER                           | 18  |
| 16   | V10119   | 5/16" -18 SS HEX NUT                        | 6   |
| 17   | 12882A   | BEARING PEDESTAL ASSEMBLY W/ 3/4" SHAFT     | 1   |
| 18   | 17040    | BOLT  | 4   |
| 19   | 17035SS  | FKM SS SEAL ASSEMBLY                        | 1   |
| 20   | 17010    | 1/2" - 24 X 1" HHCS                         | 1   |
| 21   | 12777SS  | 1/2" STAINLESS STEEL PLUG                   | 1   |
| 22   | UV15163V | O-RING FKM                                  | 1   |
| 23   | 17019    | 5/16" - 18 X 3/4" CAP SCREW                 | 8   |
| 24   | 17042    | STUD  | 6   |
| KIT  | 17100SS  | PUMP REPAIR KIT(CONSISTS OF 4,5,7,10,14,19) | 1   |

## 2" STAINLESS STEEL PUMPS

### KITS 2" SS PUMPS

| PART NO   | FKM REPAIR KIT NO |
|-----------|-------------------|
| 200PH5-SS | 17100SS           |
| 200PB-SS  | 17100SS           |
| 200PO-SS  | 17100SS           |

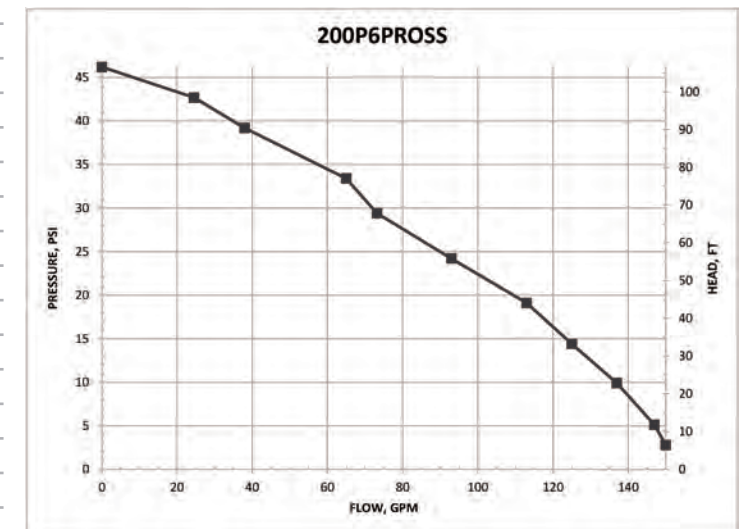



## 2" STAINLESS STEEL PUMPS WITH ELECTRIC MOTORS

### FEATURES

- Stainless steel construction for rugged dependable service
- Stainless steel shaft sleeve to protect engine shaft
- Replaceable inlet and outlet flanges
- Dynamically balanced impeller
- Due to weight and size of pumps, Banjo ships these by truck only.
- Motor warranty service available at authorized dealers
- Motor features include pressure cast aluminum end plates with ribbed design for rigidity, heavy gauge steel frame, 230 volt, with inverter spike resistance magnet wire



### 2" STAINLESS STEEL PUMPS W/ELECTRIC MOTORS

| PART NO  | DESCRIPTION   | HP | QTY | SKID QTY |
|----------|---|----|-----|----------|
| 234PE5SS | 2" STAINLESS STEEL PUMP W/5 HP THREE PHASE ELECTRIC MOTOR | 5  | 1   | 3        |



WARNING! DO NOT RUN PUMP DRY, RESTRICT OR REDUCE PORT SIZES OR DEAD HEAD PUMP



WARNING! DO NOT USE WITH FLAMMABLE LIQUIDS

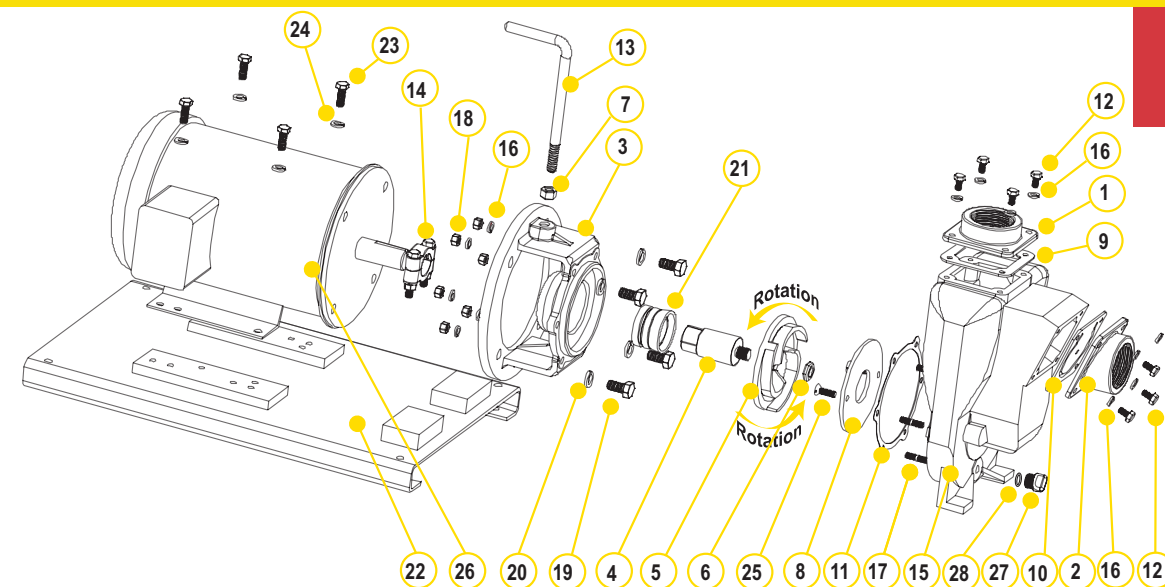

## 2" STAINLESS STEEL PUMPS WITH ELECTRIC MOTORS

### REPLACEMENT PARTS 2" STAINLESS STEEL PUMPS

| ITEM | PART NO  | DESCRIPTION                   | QTY |
|------|----------|-------------------------------|-----|
| 1    | 17000SS  | 2" NPT OUTLET FLANGE          | 1   |
| 2    | 17002SS  | 2" NPT INLET FLANGE           | 1   |
| 3    | 17446SS  | C-FACE ADAPTER                | 1   |
| 4    | 17406    | IMPELLER SHAFT                | 1   |
| 5    | 17408SS  | IMPELLER                      | 1   |
| 6    | 17009B   | 5/8" IMPELLER NUT             | 1   |
| 7    | 17010    | 1/2" HEX NUT                  | 1   |
| 8    | 17011SS  | WEAR PLATE                    | 1   |
| 9    | 17014    | FKM OUTLET GASKET             | 1   |
| 10   | 17017    | FKM GASKET & CHECK VALVE      | 1   |
| 11   | 17018    | ADAPTER GASKET                | 1   |
| 12   | 17019    | BOLT                          | 8   |
| 13   | 15022    | HANDLE                        | 1   |
| 14   | 18129    | CLAMP ASSEMBLY                | 1   |
| 15   | 17026SS  | PUMP HOUSING                  | 1   |
| 16   | V10118   | 5/16" LOCK WASHER             | 20  |
| 17   | 17042    | HOUSING STUD                  | 6   |
| 18   | V10119   | HEX NUT                       | 8   |
| 19   | N/A      | BOLT                          | 4   |
| 20   | N/A      | WASHER                        | 4   |
| 21   | 18025SS  | SEAL ASSEMBLY                 | 1   |
| 22   | 17701    | BASE PLATE ASSEMBLY           | 1   |
| 23   | 17704    | BOLT                          | 4   |
| 24   | V20018   | 3/8" LOCK WASHER              | 4   |
| 25   | 17130SS  | 5/16-18 X 1.00" FHSCS, 316 SS | 2   |
| 26   | N/A      | ELECTRIC MOTOR                | 1   |
| 27   | 12777SS  | 1/2" STAINLESS STEEL PLUG     | 1   |
| 28   | UV15163V | FKM O-RING                    | 1   |

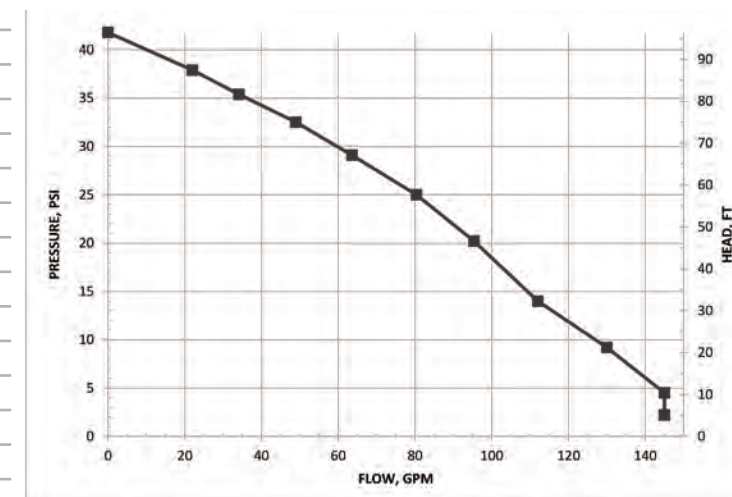

## 2" STAINLESS STEEL PUMPS WITH HYDRAULIC MOTORS

### FEATURES

- Cast iron construction for rugged dependable service
- Stainless steel hardware
- Replaceable inlet and outlet flanges
- Dynamically balanced impeller
- Hydraulic fluid capacity is minimum 6 gallons and maximum 10 gallons
- Open or closed system
- 12 HP motor
- Recommendation to use the motor spool control valve or a suitable equivalent. The lack of such a valve in this circuit may cause failure to the hydraulic motor and will void warranty.

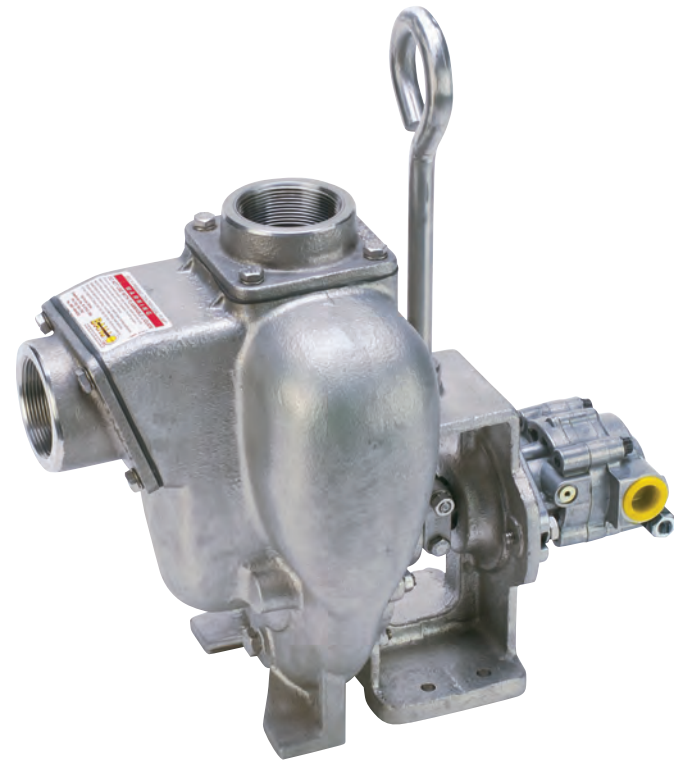

### 2" STAINLESS STEEL PUMPS W/ HYDRAULIC MOTORS

| PART NO  | DESCRIPTION                                      | HP | QTY | SKID QTY |
|----------|--|----|-----|----------|
| 200PHYSS | 2" STAINLESS STEEL PUMP W/ 12 HP HYDRAULIC MOTOR | 12 | 1   | 18       |

### SPOOL VALVE ASSEMBLY DIAGRAM

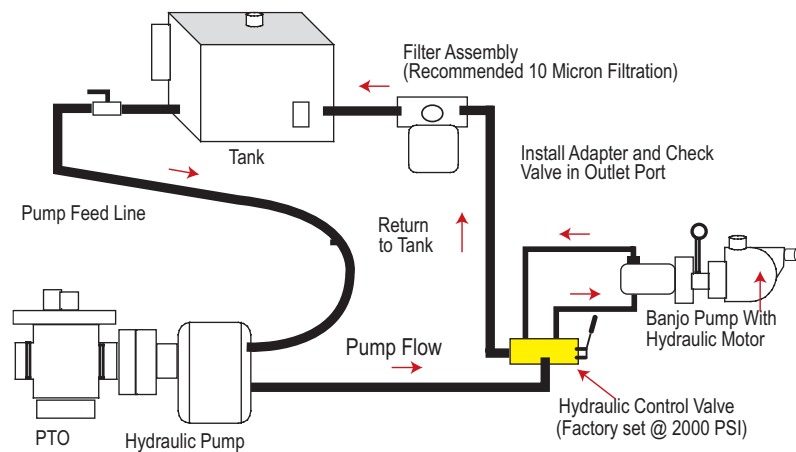

### HYDRAULIC MOTOR SPOOL VALVE

| PART NO | DESCRIPTION                 | HP  | QTY |
|---------|-----------------------------|-----|-----|
| HSV1000 | HYDRAULIC MOTOR SPOOL VALVE | N/A | 1   |

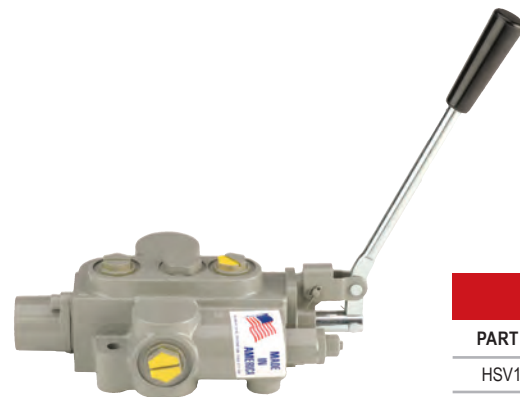

## 2" STAINLESS STEEL PUMPS WITH HYDRAULIC MOTORS

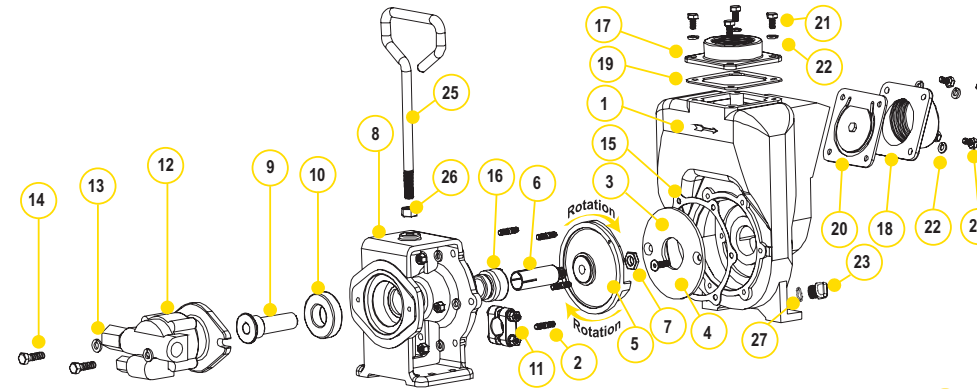

### REPLACEMENT PARTS 2" STAINLESS STEEL PUMPS

| ITEM | PART NO  | DESCRIPTION                            | QTY |
|------|----------|--|-----|
| 1    | 17026SS  | PUMP HOUSING                           | 1   |
| 2    | 17042    | PUMP HOUSING STUD                      | 6   |
| 3    | 17011SS  | WEAR PLATE                             | 1   |
| 4    | 17130SS  | 5/16-18 X 1.00" FHSCS, 316 SS          | 2   |
| 5    | 17008SS  | 5" IMPELLER                            | 1   |
| 6    | 17007    | 7/8" SLEEVE DRIVE FOR ELECTRIC MOTOR   | 1   |
| 7    | 17009B   | 5/8" IMPELLER NUT                      | 1   |
| 8    | 17049ASS | HYDRAULIC ADAPTER                      | 1   |
| 9    | 17055A   | HYDRAULIC ADAPTER SHAFT                | 1   |
| 10   | 17056    | SKF 6206-2RS1 BEARING                  | 1   |
| 11   | 17024    | 7/8" CLAMP, NO KEY                     | 1   |
| 12   | HY1013   | MGG20025BC1D3 HYDRAULIC MOTOR ASSEMBLY | 1   |
| 13   | V20018   | 3/8" LOCK WASHER                       | 2   |
| 14   | 18010SS  | 3/8" - 16 X 1.25" HHHCS                | 2   |
| 15   | 17018    | GASKET ADAPTER                         | 1   |
| 16   | 17035SS  | FKM SEAL ASSEMBLY                      | 1   |
| 17   | 17000SS  | 2" NPT OUTLET FLANGE                   | 1   |
| 18   | 17002SS  | 2" NPT INLET FLANGE                    | 1   |
| 19   | 17014    | FKM GASKET                             | 1   |
| 20   | 17017    | GASKET CHECK VALVE ASSEMBLY            | 1   |
| 21   | 17019    | 5/16"-18 X 0.75" CAP SCREW             | 8   |
| 22   | V10118   | 5/16" SPLIT LOCK WASHER                | 14  |
| 23   | 12777SS  | 1/2" STAINLESS STEEL PLUG              | 1   |
| 24   | V10119   | 5/16"-18 HEX NUT                       | 6   |
| 25   | 15022    | HANDLE                                 | 1   |
| 26   | 17010    | 1/2" HEX NUT -13UNF-RH                 | 1   |
| 27   | UV15163V | O-RING FKM                             | 1   |

### REPLACEMENT PARTS 2" HYDRAULIC ADAPTER

| ITEM | PART NO  | DESCRIPTION                | QTY |
|------|----------|----------------------------|-----|
| 1    | 17049ASS | SS HYDRAULIC MOTOR ADAPTER | 1   |
| 2    | 17018    | GASKET ADAPTER             | 1   |
| 3    | 17035SS  | SEAL ASSEMBLY              | 1   |
| N/S  | 17007    | 7/8" SS SHAFT SLEEVE       | 1   |
| 4    | 17056    | SKF 6206-2RS1 BEARING      | 1   |
| 5    | 17055A   | HYDRAULIC ADAPTER SHAFT    | 1   |
| 6    | HY1013   | GRESEN® HYDRAULIC MOTOR    | 1   |
| 7    | V20018   | LOCK WASHER                | 2   |
| 8    | 18010SS  | BOLT                       | 2   |

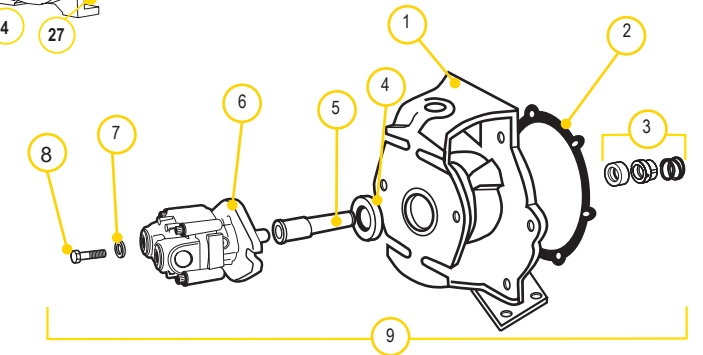

### HYDRAULIC MOTOR DATA

|                        |                        |
|------------------------|------------------------|
| U.S. GALLONS/REV.      | 0.0025                 |
| CUBIC INCHES/REV.      | 0.580                  |
| LITERS/REV.            | 0.0097                 |
| MAX HYDRAULIC PRESSURE | 2000 PSI               |
| MIN HYDRAULIC PRESSURE | 200 PSI                |
| INLET PORT             | SAE 10 (7/8-14 UNF-2B) |
| OUTLET PORT            | SAE 10 (7/8-14 UNF-2B) |
| MINIMUM GPM REQUIRED   | 6 GPM 2400 RPM         |
| MAXIMUM GPM REQUIRED   | 10 GPM 4000 RPM        |
| IDEAL GPM REQUIRED     | 9 GPM 3600 RPM         |

### CONNECTION INFORMATION

|        |          |
|--------|----------|
| INLET  | "A" PORT |
| OUTLET | "B" PORT |

SUPPLIED CHECK VALVE IS TO ENSURE PROPER ROTATION OF THE BANJO PUMP. PLACE CHECK VALVE IN OUTLET PORT (MARKED "B") FOR PROPER RIGHT HAND ROTATION.

### SPOOL VALVE INFORMATION

|                          |                            |
|--------------------------|----------------------------|
| REQUIRED OUTLET FLOW     | MIN 6 GPM / MAX 10 GPM     |
| REQUIRED SYSTEM PRESSURE | MIN 500 PSI / MAX 2000 PSI |

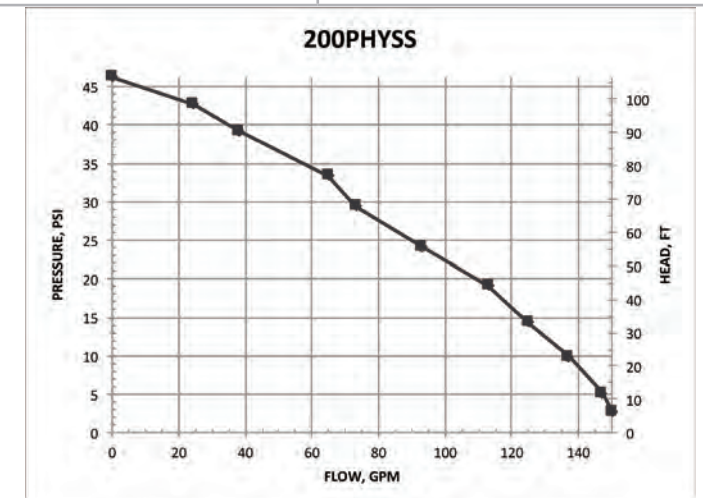

WARNING! DO NOT RUN PUMP DRY, RESTRICT OR REDUCE PORT SIZES OR DEAD HEAD PUMP



WARNING! DO NOT USE WITH FLAMMABLE LIQUIDS



## 3" STAINLESS STEEL PUMPS

### FEATURES

- 316 stainless steel housing and wettable internal components including impeller, sleeve, wear plate and fasteners
- Carbon ceramic seal with 316 stainless steel cup and spring with FKM elastomer
- Replaceable inlet and outlet flanges
- Dynamically balanced impeller
- Pump only packs complete and ready for attachment to gasoline engine
- Pedestal pump for long coupling to electric motor
- Recommendation for 5/8" shaft: 56C frame size, 3 HP, 3450 RPM & 5" max impeller for close coupling to electric motors
- Recommendation for 7/8" shaft: 145TC frame size, 3 HP, 3450 RPM & 5" max impeller for close coupling to electric motors
- Engine warranty service available at authorized dealers
- Due to weight and size of pumps, Banjo ships these by truck only.



| 3" STAINLESS STEEL PUMPS W/GAS ENGINES |   |    |     |          |  |
|--|---|----|-----|----------|--|
| PART NO                                | DESCRIPTION   | HP | QTY | SKID QTY |  |
| 300PH13SS                              | 3" SS PUMP W/13 HP HONDA® ENGINE W/ELECTRIC START & PULL ROPE | 13 | 1   | 6        |  |



| 3" STAINLESS STEEL PUMP ONLY |                                    |     |     |          |  |
|------------------------------|------------------------------------|-----|-----|----------|--|
| PART NO                      | DESCRIPTION                        | HP  | QTY | SKID QTY |  |
| 300PO-SS                     | 3" SS PUMP ONLY W/ 1" SHAFT SLEEVE | N/A | 1   | 8        |  |



| 3" STAINLESS STEEL BEARING PEDESTAL |   |     |     |          |  |
|-------------------------------------|---|-----|-----|----------|--|
| PART NO                             | DESCRIPTION                                 | HP  | QTY | SKID QTY |  |
| 300PB-SS                            | 3" SS BEARING PEDESTAL W/ 1" STRAIGHT SHAFT | N/A | 1   | 8        |  |



| 3" STAINLESS STEEL PUMPS W/ HYDRAULIC MOTOR |  |    |     |          |  |
|---|--|----|-----|----------|--|
| PART NO                                     | DESCRIPTION                                      | HP | QTY | SKID QTY |  |
| 300PHYSS                                    | 3" STAINLESS STEEL PUMP W/ 21 HP HYDRAULIC MOTOR | 12 | 1   | 8        |  |



WARNING! DO NOT RUN PUMP DRY, RESTRICT OR REDUCE PORT SIZES OR DEAD HEAD PUMP



WARNING! DO NOT USE WITH FLAMMABLE LIQUIDS

## 3" STAINLESS STEEL PUMPS

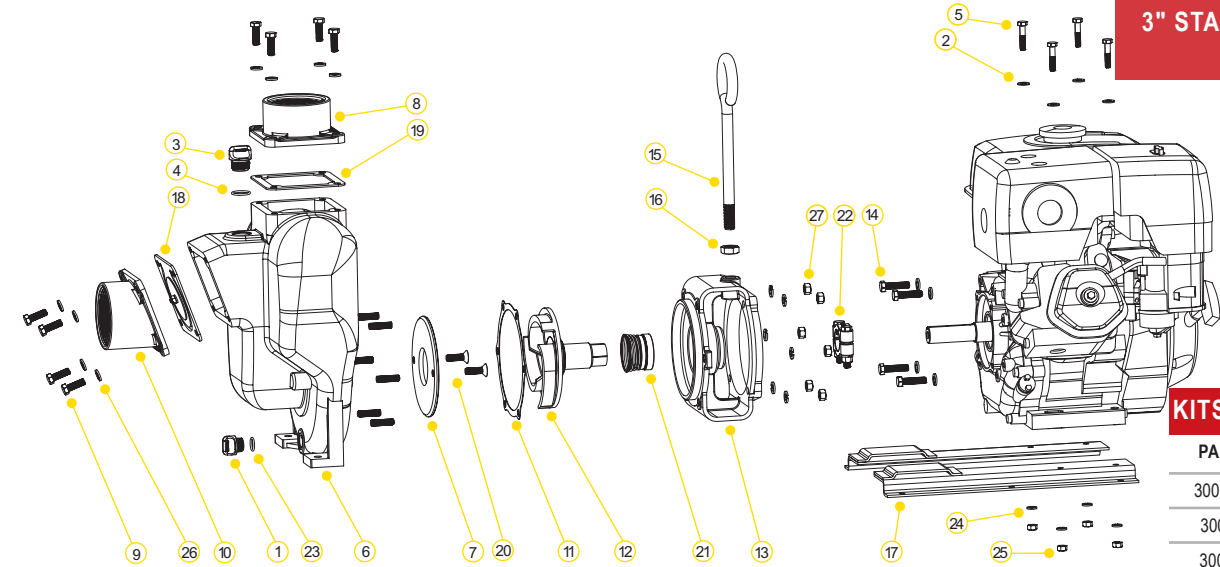

### KITS 3" SS STEEL PUMPS

| PART NO   | FKM REPAIR KIT NO |
|-----------|-------------------|
| 300PH13SS | 18100SS           |
| 300PB-SS  | 18100SS           |
| 300PO-SS  | 18100SS           |

### REPLACEMENT PARTS 3" STAINLESS STEEL PUMPS

| ITEM | PART NO       | DESCRIPTION  | QTY |
|------|---------------|--|-----|
| 1    | 12777SS       | 1/2" STAINLESS STEEL PLUG  | 1   |
| 2    | 12901         | SS REAR BRACKET WASHER   | 4   |
| 3    | 13777SS       | 3/4" STAINLESS STEEL PLUG  | 1   |
| 4    | 13778V        | O-RING FKM   | 1   |
| 5    | N/A           | 5/16" - 18 X 1 3/4" ZINC PLATED                                  | 4   |
| 6    | 18001SS       | SS PUMP HOUSING  | 1   |
| 7    | 18004SS       | SS WEAR PLATE  | 1   |
| 8    | N/A           | 3" NPT OUTLET FLANGE   | 1   |
| 9    | 18010SS       | 3/8" - 16 X 1 1/4" SS CAP SCREW HXHD                             | 8   |
| 10   | N/A           | 3" NPT INLET FLANGE  | 1   |
| 11   | 18021         | ADAPTER GASKET   | 1   |
| 12   | 18023SS       | 1" SS IMPELLER & DRIVE SHAFT FOR GAS ENGINE                      | 1   |
| 12   | 18023-1.125SS | 1 1/8" SS IMPELLER & DRIVE SHAFT FOR ELECTRIC MOTOR (300PO-SSCF) | 1   |
| 13   | 18026SS       | ADAPTER FOR GAS ENGINE   | 1   |
| 13   | 18049SS       | ADAPTER FOR HYDRAULIC MOTOR (300PHYSS)                           | 1   |
| 14   | 18027         | 3/8" - 16 X 1 1/2" HHCS  | 4   |
| 15   | 18033         | HANDLE   | 1   |
| 16   | 18034         | 5/8" SS JAM NUT  | 1   |
| 17   | 18035         | Z RAILS  | 1   |
| 18   | 18042         | FKM GASKET CHECKVALVE ASSEMBLY                                   | 1   |
| 19   | 18044         | FKM OUTLET GASKET  | 1   |
| 20   | 18106SS       | WEAR PLATE FLAT HEAD SCREW                                       | 2   |
| 21   | 18025SS       | FKM SEAL ASSEMBLY  | 1   |
| 22   | 18129         | CLAMP ASSEMBLY   | 1   |
| 23   | UV15163V      | O-RING FKM   | 1   |
| 24   | V10118        | 5/16" LOCK WASHER  | 4   |
| 25   | V10119        | 5/16" - 18 SS HEX NUT  | 4   |
| 26   | V20018        | 3/8" SS LOCK WASHER  | 18  |
| 27   | V20019        | 3/8" 16 SS HEX NUT   | 6   |
| KIT  | 18100SS       | REPAIR KIT(CONSIST OF ITEMS 7,11,12, 20 & 21)                    | 1   |

Note: Please see repair parts list for 300PHYSS on our website.

### HYDRAULIC MOTOR DATA

|                        |                 |
|------------------------|-----------------|
| U.S. GALLONS/REV.      | 0.0038          |
| CUBIC INCHES/REV.      | 0.878           |
| LITERS/REV.            | 0.0144          |
| MAX HYDRAULIC PRESSURE | 3000 PSI        |
| MIN HYDRAULIC PRESSURE | 600 PSI         |
| INLET PORT             | 1-1/16-12UN-2B  |
| OUTLET PORT            | 1-5/16-12UN-2B  |
| MINIMUM GPM REQUIRED   | 9 GPM 2370 RPM  |
| MAXIMUM GPM REQUIRED   | 13 GPM 3450 RPM |
| IDEAL GPM REQUIRED     | 9 GPM 3600 RPM  |

### CONNECTION INFORMATION

|        |          |
|--------|----------|
| INLET  | "A" PORT |
| OUTLET | "B" PORT |

SUPPLIED CHECK VALVE IS TO ENSURE PROPER ROTATION OF THE BANJO PUMP. PLACE CHECK VALVE IN OUTLET PORT (MARKED "B") FOR PROPER RIGHT HAND ROTATION. IT IS RECOMMENDED THAT A MINIMUM 3/4" INLET LINE & A MINIMUM 1" OUTLET LINE BE USED. THE OUTLET PORT MUST BE CONNECTED DIRECTLY BACK TO THE HYDRAULIC FLUID RESERVOIR & NOT TO ANY VALVING, REGULATORS OR FLOW DIVERTERS. THE OUTLET PORT/RETURN LINE BACK PRESSURE MUST NOT EXCEED 250 PSI.

### SPOOL VALVE INFORMATION

|                          |                            |
|--------------------------|----------------------------|
| REQUIRED OUTLET FLOW     | MIN 9 GPM / MAX 13 GPM     |
| REQUIRED SYSTEM PRESSURE | MIN 600 PSI / MAX 3000 PSI |

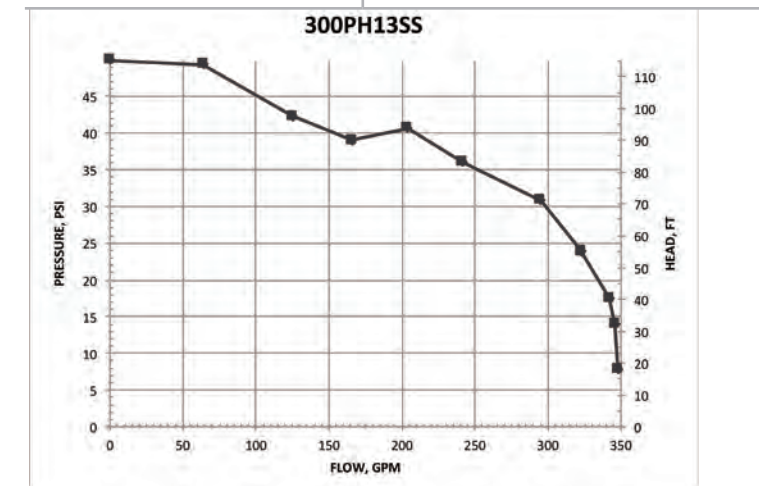

| TANK WALL GUIDE FOR BANJO TANK FITTINGS |   |                         |
|---|---|-------------------------|
| PART NO                                 | DESCRIPTION   | MAX TANK WALL THICKNESS |
| BF075                                   | ¾" BLIND HOLE TANK FLANGE                               | .250                    |
| BF075D                                  | ¾" X 1" BOTTOM DRAIN FLANGE EPDM THREAD                 | .250                    |
| BF100                                   | 1" BLIND HOLE BOLTED TANK FLANGE                        | .250                    |
| BF100BD                                 | 1" X 1" BOTTOM DRAIN FLANGE EPDM THREAD                 | .250                    |
| BF150                                   | 1½" BOLTED TANK FLANGE                                  | .280                    |
| BF150BD                                 | 1½" X 2" BOTTOM DRAIN FLANGE EPDM THREAD                | .220                    |
| BF200                                   | 2" BLIND HOLE BOLTED TANK FLANGE                        | .280                    |
| BF200BD                                 | 2" X 2" BOTTOM DRAIN FLANGE EPDM THREAD                 | .220                    |
| BF200V                                  | 2" X 2" THREADED FLANGE W/FKM GASKET                    | .280                    |
| BF220                                   | 2" FULL PORT BOLTED TANK FLANGE                         | .250                    |
| BF220BD                                 | 2" X 2" FULL PORT BOTTOM DRAIN FLANGE EPDM THREAD       | .250                    |
| BF300                                   | 3" X 3" BOLTED TANK FLANGE                              | .500                    |
| BF300BD                                 | 3" X 3" BOTTOM DRAIN FLANGE EPDM THREAD                 | .500                    |
| MBF100                                  | 1" BOLTED MANIFOLD TANK FLANGE WITH 2¼" BOLTS           | .280                    |
| MBF100BD                                | 1" BOTTOM DRAIN MANIFOLD BOLTED TANK FLANGE EPDM THREAD | .280                    |
| MBF200                                  | 2" BOLTED MANIFOLD TANK FLANGE WITH 2½" BOLTS           | .210                    |
| MBF200BD                                | 2" BOTTOM DRAIN MANIFOLD TANK FLANGE                    | .500                    |
| MBF220                                  | 2" FULL PORT MANIFOLD FLANGE WITH 2½" BOLTS             | .320                    |
| MBF220BD                                | 2" FULL PORT MANIFOLD BOTTOM DRAIN FLANGE EPDM THREAD   | .550                    |
| MBF300                                  | 3" BOLTED MANIFOLD TANK FLANGE EPDM THREAD              | .500                    |
| MBF300BD                                | 3" BOTTOM DRAIN MANIFOLD TANK FLANGE EPDM THREAD        | .500                    |

| BRIGGS & STRATTON ENGINES |                      |                      |                      |                      |                      |                                      |
|---------------------------|----------------------|----------------------|----------------------|----------------------|----------------------|--------------------------------------|
| BANJO PART NUMBER         | E3                   | E6.5PRO              | E6.5PROE             | E11PROE              | E11PRO100E           | E14VAN                               |
| MANUFACTURER              | Briggs & Stratton    | Briggs & Stratton    | Briggs & Stratton    | Briggs & Stratton    | Briggs & Stratton    | Vanguard                             |
| MODEL NUMBER              | 083132-1110-F1       | 130G32-0122-F1       | 130G37-0183-F1       | 19N137-0076-F1       | 2123320140B1G1016    | 25V337-0012-F1                       |
| RATED HP @ 3600 RPM       | 3.5                  | 6.5                  | 6.5                  | 11                   | 11                   | 14                                   |
| RATED TORQUE @ 2800 RPM   | 4.9 ft lbs           | 9 ft lbs             | 9 ft lbs             | 15.5 ft lbs          | 15.5 ft lbs          | 20.8 ft lbs                          |
| SHAFT SIZE                | ¾"                   | ¾"                   | ¾"                   | ¾"                   | 1"                   | 1"                                   |
| KEYWAY SIZE               | 3/16"                | 3/16"                | 3/16"                | 3/16"                | 1/4"                 | 1/4"                                 |
| SHAFT ID THREAD           | 5/16"-24 UNF 2B      | 5/16"-24 UNF 2B      | 5/16"-24 UNF 2B      | 5/16"-24 UNF 2B      | 3/8"-24 UNF 2B       | 3/8"-24 UNF 2B                       |
| ENGINE OIL REQUIRED       | Synthetic 5W30       | 40F+30W, 30F-5W30    | 40F+30W,30F-5W30     | Synthetic 10W30      | Synthetic 10W30      | Synthetic 5W30 suggested; see manual |
| ENGINE OIL CAPACITY       | 21 oz                | 20 oz                | 20 oz                | 28 oz                | 28 oz                | 32 oz                                |
| FUEL REQUIRED             | 87 (10% ethanol max) | 87 (10% ethanol max) | 87 (10% ethanol max) | 87 (10% ethanol max) | 87 (10% ethanol max) | 87 (10% ethanol max)                 |
| FUEL TANK CAPACITY        | 1/2 gallon           | 1 gallon             | .825 gallon          | 1 gallon             | 1 gallon             | 1 1/2 gallon                         |
| OIL ALERT                 | N                    | Y                    | Y                    | Y                    | Y                    | Y                                    |
| ELECTRIC START            | N                    | N                    | Y                    | Y                    | Y                    | Y                                    |
| OVER HEAD VALVE           | Y                    | Y                    | Y                    | Y                    | Y                    | Y                                    |

| HONDA ENGINES           |                      |                      |                      |                      |                      |                      |
|-------------------------|----------------------|----------------------|----------------------|----------------------|----------------------|----------------------|
| BANJO PART NUMBER       | E5H                  | E5HE                 | E6H                  | E8H                  | E11H                 | E13H                 |
| MANUFACTURER            | HONDA                | HONDA                | HONDA                | HONDA                | HONDA                | HONDA                |
| MODEL NUMBER            | GX160                | GX160                | GX200                | GX240                | GX340                | GX390                |
| RATED HP @ 3600 RPM     | 5.4 HP               | 5.4 HP               | 6.4 HP               | 8 HP                 | 11 HP                | 13 HP                |
| RATED TORQUE @ 2500 RPM | 8 ft lbs             | 8 ft lbs             | 7.76 ft lbs          | 12.3 ft lbs          | 17.4 ft lbs          | 19.5 ft lbs          |
| SHAFT SIZE              | ¾"                   | ¾"                   | ¾"                   | 1"                   | 1"                   | 1"                   |
| KEYWAY SIZE             | 3/16"                | 3/16"                | 3/16"                | 1/4"                 | 1/4"                 | 1/4"                 |
| SHAFT ID THREAD         | 5/16"-24 UNF 2B      | 5/16"-24 UNF 2B      | 5/16"-24 UNF 2B      | 3/8"-24 UNF 2B       | 3/8"-24 UNF 2B       | 3/8"-24 UNF 2B       |
| ENGINE OIL REQUIRED     | 10W30                | 10W30                | 10W30                | 10W30                | 10W30                | 10W30                |
| ENGINE OIL CAPACITY     | .63 QT               | .63 QT               | .63 QT               | 1.16 QT              | 1.16 QT              | 1.16 QT              |
| FUEL REQUIRED           | 86 (10% ETHANOL MAX) | 86 (10% ETHANOL MAX) | 86 (10% ETHANOL MAX) | 86 (10% ETHANOL MAX) | 86 (10% ETHANOL MAX) | 86 (10% ETHANOL MAX) |
| FUEL TANK CAPACITY      | .95 GALLON           | .95 GALLON           | .95 GALLON           | 1.59 GALLON          | 1.72 GALLON          | 1.72 GALLON          |
| OIL ALERT               | Y                    | Y                    | Y                    | Y                    | Y                    | Y                    |
| ELECTRIC START          | N                    | Y                    | N                    | Y                    | Y                    | Y                    |
| OVER HEAD VALVE         | Y                    | Y                    | Y                    | Y                    | Y                    | Y                    |

| HYDRAULIC MOTORS          |                       |                     |                     |                       |
|---------------------------|-----------------------|---------------------|---------------------|-----------------------|
| BANJO PART NUMBER         | HY1012                | HY1013              | HY11131             | HY11141A REV 01       |
| US GALLONS / REVOLUTION   | 0.0038                | 0.0025              | 0.0030              | 0.0029                |
| CUBIC INCHES / REVOLUTION | 0.878                 | 0.58                | 0.7                 | 0.671                 |
| LITERS / REVOLUTION       | 0.0144                | 0.0097              | 0.0115              | 0.0110                |
| MAX HYDRAULIC PRESSURE    | 3000 PSI              | 2000 PSI            | 1500 PSI            | 3045 PSI              |
| MIN HYDRAULIC PRESSURE    | 600 PSI               | 200 PSI             |                     | 10 PSIA               |
| INLET PORT                | SAE 12 (1 1/16-12 UN) | SAE 10 (7/8-14 UNF) | SAE 10 (7/8-14 UNF) | SAE 10 (7/8-14 UNF)   |
| OUTLET PORT               | SAE 16 (1 5/16-12 UN) | SAE 10 (7/8-14 UNF) | SAE 10 (7/8-14 UNF) | SAE 12 (1 1/16-12 UN) |
| MINIMUM GPM REQUIRED      | 9.1 GPM / 2400 RPM    | 6 GPM / 2400 RPM    | 7.3 GPM / 2400 RPM  | 7 GPM / 2400 RPM      |
| MAXIMUM GPM REQUIRED      | 15.2 GPM / 4000 RPM   | 10 GPM / 4000 RPM   | 12.1 GPM / 4000 RPM | 11.6 GPM / 4000 RPM   |
| IDEAL GPM REQUIRED        | 13.7 GPM / 3600 RPM   | 9 GPM / 3600 RPM    | 10.9 GPM / 3600 RPM | 10.5 GPM / 3600 RPM   |
| INLET PORT                | "A" PORT              | "A" PORT            | "A" PORT            | PORTS NOT LABELED     |
| OUTLET PORT               | "B" PORT              | "B" PORT            | "B" PORT            | PORTS NOT LABELED     |
| DRAIN PORT                | N/A                   | N/A                 | N/A                 | SAE 6 (9/16-18 UNF)   |
| SHAFT SIZE                | ¾"                    | 9/16"               | 9/16"               | 5/8"                  |

| SPOOL VALVE INFO         |                            |                            |
|--------------------------|----------------------------|----------------------------|
| REQUIRED OUTLET FLOW     | MIN 9 GPM / MAX 13 GPM     | MIN 6 GPM / MAX 10 GPM     |
| REQUIRED SYSTEM PRESSURE | MIN 600 PSI / MAX 3000 PSI | MIN 600 PSI / MAX 3000 PSI |



# REFERENCE

| PART NO | PAGE NO(S)  | WEIGHT | PART NO | PAGE NO(S)                                       | WEIGHT | PART NO  | PAGE NO(S)                             | WEIGHT |
|---------|---|--------|---------|--|--------|----------|--|--------|
| 12046   | 105, 137  | 0.5    | 15752   | 105, 135, 137                                    | 0.002  | 17024    | 127, 131, 133, 153, 157                | 0.128  |
| 12049   | 5, 107, 117   | 1.1    | 15772   | 135, 137, 147                                    | 1.75   | 17026    | 127, 131, 133                          | 21.23  |
| 12052   | 105, 137  | N/A    | 15999   | 135, 137   | 0.282  | 17028    | 127                                    | 0.16   |
| 12099   | 101, 105, 107, 109, 113, 115, 117, 135, 137   | 0.07   | 16001   | 145  | 4.808  | 17032    | 129                                    | 0.036  |
| 12155   | 103, 111, 119, 121  | 1.19   | 16003   | 145  | 5.688  | 17033    | 127, 135                               | 3.018  |
| 12705   | 101, 103, 105, 107, 109, 111, 113, 115, 117, 119, 121, 135, 137, 147, 149                       | 0.26   | 16011   | 145  | 0.098  | 17035    | 127, 131, 133                          | 0.18   |
| 12709   | 103, 111, 119, 121, 147, 149  | 0.001  | 16019   | 145, 151   | 0.068  | 17040    | 127, 153                               | 0.028  |
| 12710   | 101, 105, 107, 109, 113, 115, 117, 135, 137   | 0.01   | 16099   | 145  | 0.25   | 17042    | 127, 131, 153, 155, 157                | 0.02   |
| 12713   | 101, 105, 107, 109, 113, 115, 117   | 0.11   | 16702   | 145, 151   | 11     | 17046    | 127, 131                               | 7.572  |
| 12716   | 101, 105, 109, 113, 115, 135  | 0.02   | 16704   | 145  | 41.5   | 17049A   | 5, 133                                 | 10.738 |
| 12717   | 101, 103, 105, 107, 109, 111, 113, 115, 117, 119, 121, 135, 137, 147, 149                       | 0.001  | 16706   | 145  | 0.888  | 17049ASS | 57                                     | 10.46  |
| 12720   | 101, 103, 105, 107, 109, 111, 113, 115, 117, 119, 121   | 0.03   | 16707   | 151  | 4      | 17056    | 133, 157                               | 0.462  |
| 12723   | 923   | 0.01   | 16710   | 145  | 0.002  | 17100    | 127                                    | 4      |
| 12724   | 93  | 0.001  | 16712   | 151  | 58     | 17123    | 127, 129, 153                          | 0.384  |
| 12725   | 101, 103, 105, 107, 109, 111, 113, 115, 117, 119, 121, 125                                      | 0.002  | 16713   | 145  | 0.2    | 17130    | 127, 129, 131                          | 0.022  |
| 12754   | 101, 103, 105, 107, 109, 111, 113, 115, 117, 119, 121   | 0.002  | 16733   | 145  | 55     | 17202    | 129                                    | 3.738  |
| 12756   | 105, 137  | 1.44   | 16751   | 145  | 0.024  | 17208    | 129                                    | 1.802  |
| 12766   | 103, 111, 121   | 0.08   | 16752   | 145  | 0.004  | 17226    | 129                                    | 25.21  |
| 12772   | 101, 03, 105, 107, 109, 111   | 0.21   | 16765   | 145, 151   | 0.098  | 17235    | 129                                    | 0.35   |
| 12777   | 51, 89, 93, 101, 103, 105, 107, 111, 119, 121, 125, 127, 129, 131, 133, 139, 141, 143, 147, 149 | 0.018  | 16773   | 145  | 3.452  | 17242    | 129                                    | 0.032  |
| 12900   | 101, 103, 105, 107, 109, 111, 113, 115, 117, 119, 121   | 0.008  | 16774   | 145  | 2.75   | 17406    | 131, 155                               | 0.638  |
| 12901   | 101, 105, 107, 109, 113, 115, 117, 135, 137, 147, 149, 159                                      | 0.004  | 16775   | 151  | 4.242  | 17408    | 131                                    | 2      |
| 13034   | 103, 111, 119, 121, 147   | N/A    | 16901   | 119, 121, 145, 147, 149, 151                     | 0.01   | 17446    | 131                                    | 18     |
| 13055   | 119, 147, 149   | 0.674  | 16901SS | 125  | 7.48   | 17701    | 105, 131, 137, 155                     | 29.5   |
| 13702   | 113, 115, 117, 119, 121   | 1.479  | 17000   | 127, 129, 131, 135                               | 1.528  | 17704    | 105, 131, 137, 139, 141, 145, 155      | 0.046  |
| 13712   | 113, 117, 119   | 4.018  | 17001   | 127  | 1.472  | 18001    | 139, 141, 143                          | 65.65  |
| 13719   | 103, 111, 119, 121, 125, 147, 149   | 0.012  | 17002   | 127, 129, 131                                    | 1.888  | 18004    | 139, 141, 143                          | 1.628  |
| 13765   | 113, 115, 145   | 0.05   | 17003   | 127  | 1.926  | 18008    | 139, 141, 143                          | 3.802  |
| 13766   | 119, 147  | 0.084  | 17004   | 127  | 6.19   | 18009    | 139, 141, 143                          | 0.036  |
| 13771   | 113, 115, 119   | 0.204  | 17005   | 127, 153   | 0.376  | 18012    | 139, 141, 143                          | 3.906  |
| 13772   | 113, 115, 117, 119, 121   | 0.223  | 17006   | 127, 153   | 0.25   | 18013    | 139, 141, 143                          | 0.53   |
| 13777   | 53, 97, 113, 115, 117, 135, 137, 139, 141, 143, 145, 147, 149, 151                              | 0.025  | 17007   | 127, 131, 133, 153, 157                          | 0.216  | 18021    | 139, 141, 143, 159                     | 0.012  |
| 13778   | 53, 97, 113, 115, 117, 135, 137, 139, 141, 143, 145, 147, 149, 151                              | 0.002  | 17008   | 127, 131, 133                                    | 2      | 18025    | 139, 141, 143                          | 0.39   |
| 13999   | 113, 115, 117   | 0.266  | 17010   | 127, 129, 131, 133, 135, 137, 143, 153, 155, 157 | 0.036  | 18026    | 139                                    | 9.91   |
| 15000   | 135, 137  | 2.244  | 17011   | 127, 129, 131                                    | 0.866  | 18027    | 145, 151, 159                          | 0.056  |
| 15022   | 127, 129, 131, 133, 135, 137, 153, 155, 157   | 1.124  | 17013   | 127, 129, 131, 135                               | 0.034  | 18029    | 125, 139, 143                          | 0.63   |
| 15025   | 145   | N/A    | 17014   | 153, 155, 157                                    | 0.042  | 18033    | 139, 141, 143, 145, 147, 149, 151, 159 | 1.236  |
| 15035   | 119   | 0.35   | 17016   | 127, 129, 131                                    | 0.214  | 18034    | 139, 141, 143, 145, 147, 149, 151, 159 | 0.048  |
| 15702   | 135, 137  | 9.086  | 17017   | 127, 129, 131                                    | 0.262  | 18035    | 139, 159                               | 2.73   |
| 15703   | 135, 137  | 14.978 | 17018   | 127, 129, 131, 133, 153, 155, 157                | 0.01   | 18042    | 159                                    | 0.584  |
| 15712   | 135, 137  | 26.082 | 17019   | 127, 129, 131, 133, 153, 155, 157                | 0.024  | 18044    | 159                                    | 0.056  |
| 15751   | 105, 113, 115, 135, 137   | 0.014  | 17023   | 127, 153   | 0.386  | 18048    | 139                                    | 12.788 |

# REFERENCE

| PART NO   | PAGE NO(S)                        | WEIGHT | PART NO   | PAGE NO(S)  | WEIGHT | PART NO         | PAGE NO(S)                             | WEIGHT |
|-----------|-----------------------------------|--------|-----------|---|--------|-----------------|--|--------|
| 18049     | 139, 143                          | 20.516 | 125A      | 75, 76  | 0.1    | 150A            | 75, 76                                 | 0.18   |
| 18055     | 139, 143                          | 0.834  | 125B      | 75, 76  | 0.3    | 150A90          | 79                                     | 0.307  |
| 18056     | 14                                | 0.1    | 125C      | 75, 76  | 0.29   | 150B            | 75, 76                                 | 0.57   |
| 18100     | 139, 143                          | 7.2    | 125D      | 75, 76  | 0.31   | 150C            | 75, 76                                 | 0.57   |
| 18106     | 139, 141, 143                     | 0.04   | 125E      | 75, 76  | 0.11   | 150C90          | 79                                     | 0.62   |
| 18129     | 131, 139, 141, 155, 159           | 0.64   | 125F      | 75, 76  | 0.98   | 150CAP          | 75, 76                                 | 0.54   |
| 18206     | 141                               | 4.8    | 12600B    | 107, 117, 135   | 14     | 150D            | 75, 76                                 | 0.59   |
| 18218     | 139, 141, 143                     | 1.436  | 12702A    | 101, 103, 105, 107, 109, 111  | 1.21   | 150D90          | 79                                     | 0.65   |
| 18435     | 151                               | 1      | 12703A    | 101, 105, 107, 109, 113, 115, 117   | 2.37   | 150E            | 75, 76                                 | 0.21   |
| 18500     | 139, 141, 143                     | 13     | 12703AW   | 119   | 2.79   | 150F            | 75, 76                                 | 0.21   |
| 18502     | 139, 141, 143, 149                | 0.802  | 12705V    | 101, 105, 119   | 0.24   | 150F90          | 79                                     | 0.267  |
| 18504     | 139                               | 1.928  | 12707W    | 103, 111, 121   | 2.79   | 150G            | 49, 72, 78                             | 0.015  |
| 18511     | 145                               | 3.404  | 12709V    | 119   | 0.001  | 150GV           | 49, 72, 78                             | 0.3    |
| 18512     | 145                               | 0.036  | 12710V    | 101, 105  | 0.01   | 150PL           | 75, 76                                 | 0.16   |
| 18600     | 143                               | 35.02  | 12712A    | 101, 103, 105, 107  | 3.25   | 150POICF5/8-4.1 | 126                                    | 47     |
| 18700     | 99                                | 1.728  | 12713V    | 101, 105, 135, 137  | 0.12   | 150RING         | 78                                     | 0.026  |
| 18702     | 139, 141                          | 1.794  | 12715A    | 101, 107, 109, 113, 115, 117, 135, 137, 147, 149                          | 0.05   | 15999V          | 135, 137                               | 0.288  |
| 050C      | 75                                | 0.14   | 12717V    | 101, 105, 119   | 0.01   | 16704A          | 145                                    | 41.5   |
| 050D      | 75                                | 0.16   | 12719A    | 101, 103, 105, 107, 109, 111, 113, 115, 117, 121, 135, 137, 147, 149      | 0.05   | 16774A          | 145                                    | 2.931  |
| 050E      | 75                                | 0.05   | 12719AV   | 101, 105  | 0.05   | 17000SS         | 153, 155, 157                          | 1.58   |
| 050F      | 75                                | 0.06   | 12754V    | 101, 105, 119   | 0.01   | 17002SS         | 153, 155, 157                          | 2.038  |
| 075C      | 75, 76                            | 0.15   | 12765A    | 101, 105, 107, 109, 113, 115, 117, 135, 137                               | 0.05   | 17008-4.1       | 127                                    | 1.534  |
| 075CAP    | 75, 76                            | 0.13   | 12771A    | 101, 109  | 0.22   | 17008SS         | 153, 157                               | 2      |
| 075D      | 75, 76                            | 0.15   | 12775A    | 101, 103, 105, 107, 109, 111, 113, 115, 117, 119, 125                     | 0.01   | 17009B          | 127, 129, 131, 133, 153, 155, 157      | 0.022  |
| 075E      | 75, 76                            | 0.06   | 12777SS   | 153, 155, 157, 159  | 0.14   | 17011SS         | 153, 155, 157                          | 0.888  |
| 075F      | 75, 76                            | 0.06   | 12882A    | 101, 113, 115, 127, 129, 135, 153   | 7.6    | 17026SS         | 153, 155, 157                          | 32     |
| 100125CAP | 75, 76                            | 0.27   | 12883B    | 127   | 0.146  | 17035SD         | 127                                    | 0.13   |
| 100125PL  | 75, 76                            | 0.06   | 12902A    | 101, 103, 105, 107, 109, 111, 113, 115, 117, 119, 121, 135, 137, 147, 149 | 0.006  | 17035SS         | 153, 157                               | 0.18   |
| 100A      | 75, 76                            | 0.09   | 12999A    | 101, 105, 107, 109  | 0.25   | 17046SS         | 153                                    | 8.804  |
| 100B      | 75, 76                            | 0.29   | 12999AV   | 101, 105, 109   | 0.32   | 17055A          | 133, 157                               | 1.75   |
| 100C      | 75, 76                            | 0.27   | 13719V    | 119   | 0.019  | 17056E          | 107, 117                               | 2      |
| 100D      | 75, 76                            | 0.31   | 13777SS   | 159   | 0.205  | 17100SS         | 153                                    | 3.384  |
| 100E      | 75, 76                            | 0.1    | 13778V    | 159   | 0.002  | 17130SS         | 153, 155, 157                          | 0.02   |
| 100F      | 75, 76                            | 0.11   | 150(200)K | 78  | 0.134  | 17201A          | 129                                    | 8.736  |
| 100G      | 72, 78                            | 0.2    | 15000V    | 135, 137  | 2.364  | 17206A          | 129                                    | 0.628  |
| 100GV     | 72, 78                            | 0.02   | 150125A   | 75, 76  | 0.197  | 17408SS         | 155                                    | 2.106  |
| 100RING   | 78                                | 0.01   | 150125B   | 75, 76  | 0.26   | 17446SS         | 155                                    | 10.818 |
| 12000A    | 101, 105, 107, 109, 113, 115, 117 | 0.75   | 150125C   | 75, 76  | 0.568  | 18001SS         | 159                                    | 57.5   |
| 12000AV   | 101, 105, 109                     | 0.9    | 150125D   | 75, 76  | 0.31   | 18004SS         | 159                                    | 1.616  |
| 12055E    | 107, 117                          | 0.57   | 150125E   | 75, 76  | 0.16   | 18010SS         | 107, 117, 133, 139, 141, 143, 157, 159 | 0.044  |
| 12201W    | 119                               | 1.46   | 150125F   | 75, 76  | 0.18   | 18023-1.125SS   | 139, 159                               | 4.322  |
| 12202W    | 103, 111, 119, 121                | 1.46   | 15035E    | 103, 111, 119, 121, 141, 147, 149   | 0.386  | 18023SS         | 139, 143, 159                          | 4.32   |

# REFERENCE

| PART NO  | PAGE NO(S) | WEIGHT | PART NO      | PAGE NO(S) | WEIGHT | PART NO    | PAGE NO(S) | WEIGHT |
|----------|------------|--------|--------------|------------|--------|------------|------------|--------|
| 18025SD  | 139, 143   | 0.32   | 200P6PROE    | 100, 101   | 56.33  | 222PBI     | 134, 135   | 70     |
| 18025SS  | 155, 159   | 0.25   | 200P6PROV    | 100, 101   | 51     | 222PI6PRO  | 134, 135   | 100    |
| 18026SS  | 159        | 10.11  | 200PB        | 100, 101   | 15.786 | 222PIE5    | 134, 135   | 180    |
| 18055H   | 149        | 0.75   | 200PBI       | 126        | 48     | 222PIE51   | 134, 135   | 190    |
| 18100SS  | 159        | 7.5    | 200PB-SS     | 152, 153   | 52     | 222PIH5    | 134, 135   | 82     |
| 18106SS  | 159        | 0.04   | 200PH-5      | 100, 101   | 51     | 222PIH5E   | 134, 135   | 110    |
| 18200A   | 141        | 31.6   | 200PH-5E     | 100, 101   | 56.33  | 222PIH6    | 134, 135   | 110    |
| 18202A   | 141        | 4.918  | 200PH5-SS    | 152, 153   | 105    | 222POI     | 134, 135   | 60     |
| 18203A   | 141        | 4.92   | 200PH-5V     | 100, 101   | 48     | 231MPT     | 69         | 0.074  |
| 19001H   | 149        | 10.7   | 200PH5W      | 102        | 53     | 234PE5SS   | 154        | 168    |
| 19201W   | 147, 149   | 10     | 200PH6       | 100, 101   | 50.33  | 234PIE5    | 130, 131   | 160    |
| 19703W   | 147, 149   | 17.006 | 200PHA       | 106, 107   | 25     | 234PIE51   | 130        | 200    |
| 19772SS  | 147, 149   | 1.81   | 200PHY       | 106, 107   | 21.308 | 234POI     | 130        | 40.51  |
| 200150C  | 77         | 0.66   | 200PHYSS     | 156        | 52     | 234PPE5    | 104, 105   | 135    |
| 200A     | 77         | 0.3    | 200PHYW      | 106        | 28     | 234PPE51   | 104, 105   | 145.5  |
| 200A90   | 79         | 0.461  | 200PI-3      | 126        | 81     | 234PPE51V  | 104, 105   | 145    |
| 200B     | 77         | 0.64   | 200PI6PRO    | 126        | 81.5   | 234PPE5V   | 104, 105   | 123    |
| 200B90   | 79         | 0.948  | 200PIH-5     | 126        | 81.5   | 250CAP     | 75, 77     | 0.68   |
| 200C     | 77         | 0.69   | 200PIH5E     | 126        | 76.07  | 300A       | 75, 77     | 0.48   |
| 200C90   | 79\        | 0.78   | 200PIHA      | 5          | 40.76  | 300B       | 75, 77     | 1.17   |
| 200CAP   | 69, 77     | 0.6    | 200PIHY      | 132        | 48     | 300C       | 75, 77     | 1.4    |
| 200CAPSH | 69, 77     | 0.52   | 200PKL       | 78         | 0.02   | 300CAP     | 75, 77     | 1.07   |
| 200D     | 77         | 0.66   | 200PL        | 75, 77     | 0.21   | 300D       | 75, 77     | 1.19   |
| 200D90   | 79         | 0.88   | 200PO        | 100, 101   | 7.286  | 300E       | 75, 77     | 0.78   |
| 200E     | 77         | 0.32   | 200POI       | 126        | 52.5   | 300F       | 75, 77     | 0.57   |
| 200F     | 77         | 0.31   | 200POICF5/8  | 126        | 47     | 300F200F   | 78         | 0.609  |
| 200F45   | 79         | 0.346  | 200POICF7/8  | 126        | 47     | 300FF      | 78         | 0.644  |
| 200F90   | 79         | 0.434  | 200PO-SS     | 152, 153   | 47     | 300G       | 49, 72, 78 | 0.04   |
| 200FF    | 78         | 0.331  | 200POSSCF5/8 | 152        | 47     | 300GV      | 49, 72, 78 | 0.06   |
| 200G     | 49, 72, 78 | 0.02   | 200PO-V      | 100, 101   | 10     | 300K       | 78         | 0.23   |
| 200GV    | 49, 72, 78 | 0.03   | 200SBS       | 99         | 0.25   | 300P       | 78         | 0.036  |
| 200KL    | 78         | 0.18   | 201B         | 77         | 0.71   | 300P11PRO  | 112, 113   | 81     |
| 200P     | 78         | 0.17   | 201CAPSH     | 69         | 0.566  | 300P11PROW | 118, 119   | 67     |
| 200P6PRO | 100, 101   | 50     | 201FPT       | 69         | 0.04   | 300PB      | 112, 113   | 20     |
|          |            |        | 201PBIW      | 128        | 58     | 300PBI     | 138        | 125    |
|          |            |        | 201PIH5W     | 128        | 94     | 300PB-SS   | 158, 159   | 99     |
|          |            |        | 201POIW      | 128        | 59     | 300PBW     | 118        | 26     |
|          |            |        | 202CAP       | 9*         | 0.34   | 300PH13SS  | 159, 159   | 150    |
|          |            |        | 205PB        | 100, 101   | 16     | 300PH13W   | 118, 119   | 103    |
|          |            |        | 205PB-V      | 100, 101   | 16     | 300PH-6    | 112, 113   | 50     |
|          |            |        | 205POW       | 102        | 8.5    | 300PH6W    | 118, 119   | 56     |
|          |            |        | 211FPT       | 69         | 0.03   | 300PHY     | 116, 117   | 26     |

# REFERENCE

| PART NO    | PAGE NO(S) | WEIGHT | PART NO    | PAGE NO(S)  | WEIGHT | PART NO  | PAGE NO(S)                   | WEIGHT |
|------------|------------|--------|------------|---|--------|----------|------------------------------|--------|
| 300PHYSS   | 158, 159   | 140    | 75GV       | 49, 78  | 0.13   | BF220BD  | 71, 160                      | 1.5    |
| 300PHYW    | 116        | N/A    | 75PL       | 75, 76  | 0.05   | BF220GE  | 70, 71                       | 0.154  |
| 300PIH13   | 138        | 176    | A204       | 101, 103, 105, 107, 109, 111, 113, 115, 117, 119, 121, 135, 137, 147, 149 | 0.001  | BF220GV  | 70, 71                       | 0.08   |
| 300PIHY    | 142        | 140    | A204V      | 101, 105, 119   | 0.002  | BF300    | 70, 160                      | 2.264  |
| 300PL      | 75, 77     | 0.43   | AF100      | 74  | 0.304  | BF300BD  | 71, 160                      | 2.42   |
| 300PO      | 112, 113   | 12.005 | AF100G     | 74  | 0.06   | BF300GE  | 70, 71                       | 0.2    |
| 300POI     | 138        | 106    | AF100GV    | 74  | 0.06   | BF300GFE | 71                           | 0.02   |
| 300POICF   | 138        | N/A    | AF150      | 74  | 0.43   | BF300GFV | 71                           | 0.02   |
| 300POICF55 | 138        | N/A    | AF150G     | 74  | 0.08   | BF300GV  | 70, 71                       | 0.1    |
| 300PO-SS   | 158, 159   | 115    | AF200      | 74  | 0.657  | CAP038   | 82                           | 0.03   |
| 300POW     | 118        | 15.3   | AF200G     | 74  | 0.17   | CAP050   | 82                           | 0.06   |
| 300POW6    | 118, 119   | N/A    | AF200GV    | 74  | 0.17   | CAP075   | 82                           | 0.052  |
| 300SBS     | 99         | 0.25   | AF300      | 74  | 1.175  | CAP100   | 82                           | 0.09   |
| 301PBIW    | 140        | 135    | AF300G     | 74  | 0.17   | CAP125   | 82                           | 0.13   |
| 301PIH13W  | 140        | 181.37 | AF300GV    | 74  | 0.17   | CAP150   | 82                           | 0.12   |
| 301POIW    | 140        | 130    | AF400      | 74  | 1.587  | CAP200   | 82                           | 0.25   |
| 303B       | 75, 77     | 1.634  | AF400G     | 74  | 0.45   | CAP300   | 82                           | 0.59   |
| 303B200A   | 77         | 1.554  | AF400GV    | 74  | 0.45   | CPLG025  | 81                           | 0.03   |
| 303C       | 75, 77     | 1.74   | AFB200     | 74  | 0.698  | CPLG038  | 81                           | 0.026  |
| 305PHAW    | 114        | 27.07  | AFB300     | 74  | 1.42   | CPLG050  | 81                           | 0.09   |
| 333PBI     | 144, 145   | 185    | BEM10-100  | 5, 147  | N/A    | CPLG075  | 81                           | 0.11   |
| 333PIE15   | 144, 145   | 242    | BEM101-100 | 5, 147  | 145    | CPLG100  | 81                           | 0.13   |
| 333PIH13   | 144, 145   | 285    | BEM15      | 5   | 169    | CPLG125  | 81                           | 0.19   |
| 333POI     | 144, 145   | 90     | BEM15-100  | 5, 125  | 169    | CPLG150  | 81                           | 0.3    |
| 333POICF   | 5, 144     | 190    | BEM5       | 5   | 140    | CPLG200  | 81                           | 0.34   |
| 400A       | 75, 77     | 1.27   | BEM5-182CZ | 105, 137  | 95     | CPLG300  | 81                           | 0.836  |
| 400B       | 75, 77     | 2.03   | BF075      | 70, 160   | 0.82   | CR025    | 5, 82                        | 0.04   |
| 400C       | 75, 77     | 2.39   | BF075BD    | 71  | 0.88   | CR038    | 5, 82                        | 0.05   |
| 400CAP     | 75, 77     | 1.44   | BF100      | 70, 160   | 0.82   | CR050    | 82                           | 0.13   |
| 400D       | 75, 77     | 2.07   | BF100BD    | 71, 160   | 0.9    | CR075    | 82                           | 0.35   |
| 400E       | 75, 77     | 1.786  | BF100GE    | 69, 71  | 0.07   | CR100    | 82                           | 0.27   |
| 400F       | 75, 77     | 1.42   | BF100GRE   | 71  | 0.01   | CR125    | 82                           | 0.726  |
| 400G       | 78         | 0.06   | BF100GRV   | 71  | 0.01   | CR150    | 82                           | 0.571  |
| 400PL      | 75, 77     | 1.11   | BF150      | 70, 160   | 1.26   | CR200    | 82                           | 0.744  |
| 444PIH24   | 150        | 345    | BF150BD    | 71, 160   | 1.32   | CV050    | 19                           | 0.27   |
| 444POI     | 150        | 120    | BF200      | 70, 160   | 1.07   | CV100    | 19                           | 0.222  |
| 75A1/2     | 75         | 0.07   | BF200BD    | 71, 160   | 1.2    | CV100MT  | 19                           | 0.17   |
| 75A1/4     | 75         | 0.08   | BF200GE    | 70, 71  | 0.05   | CV100V   | 5, 19                        | 0.217  |
| 75A3/4     | 75, 76     | 0.05   | BF200GFV   | 69  | 0.05   | CV10175  | 103, 111, 119, 121, 147, 149 | 0.2    |
| 75B1/2     | 75         | 0.14   | BF200GV    | 70, 71  | 0.05   | CV10175V | 119                          | 0.003  |
| 75B3/4     | 75, 76     | 0.14   | BF200V     | 70, 160   | 1.07   | CV221    | 19                           | 1      |
| 75G        | 78         | 0.1    | BF220      | 70, 160   | 1.45   | CV300    | 19                           | 1.45   |



| PART NO   | PAGE NO(S) | WEIGHT | PART NO   | PAGE NO(S)     | WEIGHT | PART NO    | PAGE NO(S) | WEIGHT |
|-----------|------------|--------|-----------|----------------|--------|------------|------------|--------|
| CV301     | 19         | 1.518  | DM200DCF  | 39             | 2.75   | EL025-90   | 83         | 0.016  |
| DF100A    | 4, 64      | 0.183  | DM200DE   | 57             | 3      | EL038-90   | 83         | 0.04   |
| DF100D    | 4, 64      | N/A    | DM200DSS  | 62             | 6.9    | EL050-90   | 83         | 0.07   |
| DB20153M  | 56, 57     | 0.158  | DM200DSST | 62             | 6.9    | EL075-90   | 83         | 0.1    |
| DB20290   | 56, 57     | 0.004  | DM200DT   | 5, 57          | 2.75   | EL100-45   | 83         | 0.14   |
| DB20295   | 56, 57     | 0.002  | DM200PL   | 56, 57         | 0.49   | EL100-90   | 83         | 0.15   |
| DM100ABSS | 60         | 3.5    | DM20153F  | 56, 57         | 0.251  | EL125-90   | 83         | 0.22   |
| DM100ASS  | 60         | 3.5    | DM20153M  | 56, 57         | 0.417  | EL150-90   | 83         | 0.33   |
| DM100CAP  | 60         | 0.19   | DM201SS   | 61, 62         | 1.158  | EL200-90   | 83         | 0.434  |
| DM100DBSS | 60         | 3.75   | DM20200A  | 56, 57         | 0.242  | EL300-90   | 83         | 1.195  |
| DM100DSS  | 60         | 3.75   | DM20200D  | 56, 57         | 0.254  | EVX071     | 21         | 3.82   |
| DM100DSSE | 60         | 3.75   | DM20294A  | 56, 57, 61, 62 | 0.016  | EVX100BL   | 24         | 4.313  |
| DM100PL   | 60         | 0.234  | DM20295A  | 57, 61, 62     | 0.01   | EVX100SL   | 24         | 4.313  |
| DM101SS   | 60         | 0.346  | DM20296   | 56, 57, 61, 62 | 0.125  | EVX101     | 21         | 3.892  |
| DM10294A  | 60         | 0.01   | DM202SSV  | 61, 62         | 1.32   | EVX121     | 21         | 3.832  |
| DM10295A  | 60         | 0.006  | DM220A    | 58             | 4.3    | EVX151     | 21         | 5.103  |
| DM10296   | 60         | 0.1    | DM220ABSS | 63             | 0.43   | EVX200BL   | 24         | 4.876  |
| DM102SSV  | 60         | 0.386  | DM220ASS  | 63             | 7.8    | EVX200SL   | 24         | 4.876  |
| DM150A    | 56         | 2.64   | DM220CAP  | 58, 63         | 1      | EVX201     | 22         | 4.312  |
| DM150AB   | 56         | 2.2    | DM220D    | 58             | 5.482  | EVX220BL   | 24         | 6.253  |
| DM150ABSS | 61         | 6.3    | DM220DBSS | 63             | 7      | EVX220SL   | 24         | 6.253  |
| DM150AE   | 56         | 2.75   | DM220DSS  | 63             | 9.8    | EVX221     | 22         | 5.052  |
| DM150ASS  | 61         | 6.35   | DM221PL   | 58             | 0.3079 | EVX300     | 23         | 9.24   |
| DM150D    | 56         | 2.64   | DM221SS   | 63             | 0.206  | EVXR071    | 21         | 4.411  |
| DM150DB   | 56         | 2.2    | DM222SS   | 63             | 0.216  | EVXR101    | 21         | 3.96   |
| DM150DBSS | 61         | 6.9    | DM25153M  | 58             | 0.457  | EVXR151    | 21         | 4.45   |
| DM150DE   | 56         | 2.82   | DM25200   | 58             | 0.106  | EVXR201    | 22         | 5.33   |
| DM150DSS  | 61         | 6.9    | DM25294   | 63             | 0.0416 | EVXR221    | 22         | 5.92   |
| DM150DSSE | 61         | 6.9    | DM25294T  | 63             | 0.048  | EVXR300    | 23         | 9.24   |
| DM200A    | 57         | 3.007  | DM300ACF  | 39             | 7.72   | FC100      | 49         | 0.25   |
| DM200AB   | 57         | 2.2    | DM300AFP  | 59             | 4.8    | FC200      | 49         | 0.23   |
| DM200ABSS | 62         | 5.768  | DM300CAP  | 59             | 2.82   | FC220      | 41, 49     | 0.25   |
| DM200ACAP | 61, 62     | 1      | DM300DCF  | 39             | 8.4    | FC220B     | 49         | 1.364  |
| DM200ACF  | 39         | 3.15   | DM300DFP  | 59             | 8.4    | FC220TB    | 49         | 0.43   |
| DM200AE   | 57         | 2.75   | DM300PL   | 59             | 0.509  | FC300      | 41, 49     | 0.34   |
| DM200APL  | 61, 62     | 0.49   | DM35153F  | 59             | 0.463  | FC300B     | 49         | 1.76   |
| DM200ASS  | 62         | 6.2    | DM35153M  | 59             | 0.659  | FC300TB    | 49         | 0.52   |
| DM200AT   | 5, 57      | 2.2    | DM35200   | 59             | 1.23   | GHFT075A   | 79         | 0.06   |
| DM200CAP  | 56, 57     | 0.38   | DMMT201A  | 57             | 2.5    | GHFT075D   | 79         | 0.17   |
| DM200D    | 57         | 2.75   | DPCF100   | 65             | 0.5    | GHFT075G   | 79         | 0.025  |
| DM200DB   | 57         | 2.2    | DPCM100   | 65             | 0.25   | GHFT075MPT | 79         | 0.04   |
| DM200DBSS | 62         | 6.9    | DPCMT100  | 65             | 0.27   | GHMT075B   | 79         | 0.14   |

| PART NO      | PAGE NO(S) | WEIGHT | PART NO        | PAGE NO(S) | WEIGHT | PART NO      | PAGE NO(S)                   | WEIGHT |
|--------------|------------|--------|----------------|------------|--------|--------------|------------------------------|--------|
| GHMT075F     | 79         | 0.05   | HB100/075-90   | 84         | 0.06   | HBT050       | 85                           | 0.03   |
| GHMT075FPT   | 79         | 0.04   | HB100/125-90   | 84         | 0.1    | HBT050-038   | 5, 85                        | 0.02   |
| GHMT075MPT   | 79         | 0.04   | HB100-075      | 84         | 0.06   | HBT050-075   | 85                           | 0.03   |
| GHN075       | 79         | 0.6    | HB100-075SS    | 84         | 0.3    | HBT075       | 85                           | 0.05   |
| H25053       | 8          | 0.265  | HB100-125      | 84         | 0.08   | HBT075-050   | 85                           | 0.04   |
| HB025        | 84         | 0.01   | HB100-90       | 84         | 0.07   | HBT075-050SS | 83                           | 0.246  |
| HB025/038-90 | 84         | 0.01   | HB100SS        | 84         | 0.3    | HBT075-100   | 85                           | 0.06   |
| HB025/050-90 | 84         | 0.022  | HB125          | 84         | 0.1    | HBT100       | 85                           | 0.08   |
| HB025-038    | 84         | 0.012  | HB125/100-90   | 84         | 0.09   | HBT100-075   | 85                           | 0.06   |
| HB025-038SS  | 84         | 0.07   | HB125/150-90   | 84         | 0.09   | HBT100-100   | 85                           | 0.08   |
| HB025-050    | 84         | 0.015  | HB125-075      | 84         | 0.08   | HBT150-100   | 85                           | 0.218  |
| HB025-050SS  | 84         | 0.07   | HB125-100      | 84         | 0.09   | HBT150-150   | 85                           | 0.235  |
| HB025-90     | 84         | 0.01   | HB125-150      | 84         | 0.1    | HBT200       | 85                           | 0.388  |
| HB025SS      | 84         | 0.04   | HB125-90       | 84         | 0.11   | HBT300       | 85                           | 1.161  |
| HB038        | 84         | 0.01   | HB125SS        | 84         | 0.5    | HM038        | 85                           | 0.03   |
| HB038-025    | 5, 84      | 0.02   | HB150          | 84         | 0.13   | HM050        | 85                           | 0.01   |
| HB038-050    | 84         | 0.02   | HB150/125-90   | 84         | 0.16   | HM075        | 85                           | 0.026  |
| HB038-050SS  | 84         | 0.1    | HB150-100      | 84         | 0.09   | HM100        | 85                           | 0.04   |
| HB038-90     | 84         | 0.02   | HB150-125      | 84         | 0.1    | HM125        | 85                           | 0.07   |
| HB038SS      | 84         | 0.09   | HB150-200      | 84         | 0.19   | HM150        | 85                           | 0.08   |
| HB050        | 84         | 0.03   | HB150-90       | 84         | 0.23   | HM200        | 85                           | 0.22   |
| HB050/038-90 | 84         | 0.024  | HB150SS        | 84         | 0.68   | HM300        | 85                           | 0.763  |
| HB050/075-90 | 84         | 0.04   | HB200          | 84         | 0.2    | HSV1000      | 106, 116, 132, 142, 148, 156 | 11     |
| HB050-025    | 84         | 0.03   | HB200/150-90   | 84         | 0.22   | HV200        | 40                           | 0.58   |
| HB050-038    | 84         | 0.02   | HB200-150      | 84         | 0.18   | HY1001       | 143                          | 1.5    |
| HB050-058SS  | 84         | 0.128  | HB200-90       | 84         | 0.33   | HY1003       | 107, 117                     | 1.5    |
| HB050-075    | 84         | 0.03   | HB200SS        | 84         | 1.13   | HY1012       | 143, 149, 161                | 13.2   |
| HB050-075SS  | 84         | 0.2    | HB300          | 84         | 0.703  | HY1013       | 107, 117, 157, 161           | 4.5    |
| HB050-90     | 84         | 0.03   | HB300-90       | 84         | 1.078  | L200B        | 78                           | 0.64   |
| HB050SS      | 84         | 0.13   | HB300SS        | 84         | 3.55   | L200C        | 78                           | 0.7    |
| HB075        | 84         | 0.04   | HB400          | 84         | 1.64   | L200CAP      | 78                           | 0.62   |
| HB075/050-90 | 84         | 0.04   | HBB20012590    | 83         | 0.25   | L200D        | 78                           | 0.736  |
| HB075/100-90 | 84         | 0.05   | HBC050075      | 82         | 0.028  | LEV038       | 25                           | 0.55   |
| HB075-038    | 84         | 0.03   | HBEL100-90     | 83         | 0.06   | LEV038PL     | 25                           | 0.08   |
| HB075-050    | 84         | 0.03   | HBEL150/100-90 | 83         | 0.197  | LEV050       | 25                           | 0.6    |
| HB075-050SS  | 84         | 0.2    | HBF075         | 84         | 0.06   | LS050-20     | 92                           | 0.35   |
| HB075-058    | 84         | 0.038  | HBF075-100     | 84         | 0.08   | LS050-40     | 92                           | 0.35   |
| HB075-100    | 84         | 0.05   | HBF075-90      | 84         | 0.06   | LS050-80     | 92                           | 0.37   |
| HB075-100SS  | 84         | 0.25   | HBF100         | 84         | 0.09   | LS050B/C1    | 93                           | 0.298  |
| HB075-90     | 84         | 0.05   | HB100-90       | 5, 84      | 0.07   | LS075-20     | 92                           | 0.3    |
| HB075SS      | 84         | 0.2    | HBT025         | 5, 85      | 0.039  | LS075-40     | 92                           | 0.33   |
| HB100        | 84         | 0.06   | HBT038         | 85         | 0.03   | LS075-80     | 92                           | 0.35   |

| PART NO   | PAGE NO(S) | WEIGHT | PART NO    | PAGE NO(S)             | WEIGHT | PART NO    | PAGE NO(S) | WEIGHT |
|-----------|------------|--------|------------|------------------------|--------|------------|------------|--------|
| LS075B/C1 | 93         | 0.28   | LS250      | 51, 91, 95             | 0.13   | LSS330     | 97         | 0.368  |
| LS075-G   | 93         | 0.004  | LS250P     | 95                     | 0.116  | LSS350     | 97         | 0.366  |
| LS100-20  | 92         | 0.91   | LS280      | 51, 91, 95             | 0.1    | LST075-100 | 88         | 0.83   |
| LS100-40  | 92         | 0.9    | LS300EC    | 53, 97                 | 0.626  | LST075-16  | 88         | 0.824  |
| LS100-80  | 92         | 0.96   | LS304      | 53, 97                 | 0.598  | LST075-30  | 88         | 0.84   |
| LS100B/C1 | 93         | 0.872  | LS308      | 53, 97                 | 1.106  | LST075-50  | 88         | 0.84   |
| LS100-C1  | 93         | 0.232  | LS312      | 53, 97                 | 4.31   | LST075-80  | 88         | 0.83   |
| LS100-G   | 93         | 0.02   | LS320      | 53, 97                 | 1.03   | LST075-H   | 89         | 0.516  |
| LS100-GV  | 93         | 0.02   | LS350      | 53, 97                 | 0.92   | LST075-HB  | 89         | 0.738  |
| LS120     | 51, 93     | 0.07   | LS720      | 93                     | 0.04   | LST100-100 | 88         | 0.76   |
| LS125-20  | 92         | 0.86   | LS740      | 93                     | 0.04   | LST100-16  | 88         | 0.78   |
| LS125-40  | 92         | 0.84   | LS780      | 93                     | 0.04   | LST100-30  | 88         | 0.79   |
| LS125-80  | 92         | 0.9    | LSM300-04  | 96                     | 8      | LST100-50  | 88         | 0.81   |
| LS125B/C1 | 93         | 0.826  | LSM300-08  | 96                     | 8      | LST100-80  | 88         | 0.78   |
| LS140     | 51, 93     | 0.07   | LSM300-12  | 96                     | 8      | LST100-B   | 51, 89     | 2.17   |
| LS150-06  | 94         | 2.42   | LSM300-20  | 96                     | 8      | LST100-G   | 51, 89     | 0.02   |
| LS150-12  | 94         | 2.42   | LSM300-50  | 96                     | 8      | LST100-GV  | 51, 89     | 0.02   |
| LS150-120 | 94         | 2.5    | LSQ150-B/C | 5, 90, 91              | 3.8    | LST100-H   | 89         | 0.472  |
| LS150-20  | 94         | 2.42   | LSQ200-06  | 90                     | 4.17   | LST100-HB  | 89         | 2.25   |
| LS150-30  | 94         | 2.5    | LSQ200-20  | 90                     | 4.17   | LST1100    | 51, 89     | 0.07   |
| LS150-50  | 94         | 2.5    | LSQ200-30  | 90                     | 4.17   | LST116     | 51, 89     | 0.084  |
| LS150-80  | 94         | 2.5    | LSQ200-50  | 90                     | 4.17   | LST125-16  | 88         | 2.032  |
| LS150B/C  | 95         | 1.91   | LSQ200-80  | 90                     | 4.17   | LST125-30  | 88         | 2.22   |
| LS150-C   | 51, 95     | 0.576  | LSQ200-B/C | 91                     | 3.63   | LST125-50  | 88         | 2.24   |
| LS150-G   | 51,95      | 0.03   | LSQ200-C   | 91                     | 1.74   | LST125-80  | 88         | 2.18   |
| LS150-GV  | 51, 95     | 0.03   | LSQ200-G   | 91                     | 0.05   | LST125-HB  | 89         | 1.846  |
| LS180     | 51, 93     | 2.12   | LSQ200-GV  | 5, 91                  | 0.162  | LST130     | 51, 89     | 0.07   |
| LS200-06  | 94         | 2.5    | LSQ200-PL  | 50, 51, 53, 89, 91, 95 | 0.042  | LST150     | 51, 89     | 0.07   |
| LS200-100 | 94         | 2      | LSQ200-R   | 50, 51, 53, 89         | 0.002  | LST150-100 | 88         | 1.9    |
| LS200-12  | 94         | 2.33   | LSQ200R1   | 91                     | 0.002  | LST150-30  | 88         | 2.12   |
| LS200-120 | 94         | 2      | LSQ200-RV  | 91, 95                 | 0.004  | LST150-50  | 88         | 2.15   |
| LS200-20  | 94         | 2.33   | LSS300-BC  | 96, 97                 | 23.88  | LST150-80  | 88         | 2.13   |
| LS200-30  | 94         | 2.42   | LSS300-C   | 5, 96, 97              | 2.91   | LST150-B   | 51, 89     | 0.22   |
| LS200-50  | 94         | 2.42   | LSS300-G   | 96, 97                 | 0.1    | LST150-G   | 51, 89     | 0.014  |
| LS200-80  | 94         | 2.42   | LSS300-GV  | 96, 97                 | 0.044  | LST150-GV  | 51, 89     | 0.024  |
| LS200B/C  | 95         | 2      | LSS300-H   | 97                     | 1.724  | LST150-HB  | 89         | 1.794  |
| LS206     | 51, 91, 95 | 0.3    | LSS300-S   | 96, 97                 | 0.032  | LST15100   | 51, 89     | 0.27   |
| LS2100    | 95         | 0.09   | LSS300-SV  | 96, 97                 | 0.05   | LST1516    | 51, 89     | 0.196  |
| LS212     | 51, 91, 95 | 0.29   | LSS306     | 97                     | 0.198  | LST1530    | 51, 89     | 0.17   |
| LS2120    | 51, 91, 95 | 0.08   | LSS308     | 97                     | 0.256  | LST1550    | 51, 89     | 0.15   |
| LS220     | 51, 91, 95 | 0.2    | LSS312     | 97                     | 0.37   | LST1580    | 51, 89     | 0.1    |
| LS230     | 51, 91, 95 | 0.188  | LSS320     | 97                     | 0.4    | LST180     | 51, 89     | 0.07   |

| PART NO      | PAGE NO(S) | WEIGHT | PART NO       | PAGE NO(S) | WEIGHT | PART NO         | PAGE NO(S) | WEIGHT |
|--------------|------------|--------|---------------|------------|--------|-----------------|------------|--------|
| LST200-10SS  | 90         | 16     | LV050100MTLV  | 9          | 0.125  | M100GV          | 49         | 0.02   |
| LST200-50SS  | 90         | 16     | LV050100MTV   | 9          | 0.11   | M100MPT         | 46         | 0.08   |
| LST200-B     | 91         | 1.946  | LV050MTV      | 9          | 0.096  | M100MPTSS       | 46         | 0.34   |
| LST200-GV    | 91         | 0.04   | LV050SLV      | 9          | 0.12   | M100PA          | 40         | 0.25   |
| LST200-HSS   | 91         | 1.614  | LV050SLV      | 9          | 0.08   | M100PAC         | 40         | 0.32   |
| LST204SS     | 53, 91     | 0.416  | LV050V        | 9          | 0.084  | M100PAT         | 40         | 0.65   |
| LST206SS     | 53, 91     | 0.382  | LVHB038050MTV | 9          | 0.064  | M100PLG         | 47         | 0.05   |
| LST208SS     | 53, 91     | 0.326  | LVHB038V      | 9          | 0.06   | M100PLG025      | 6, 47      | 0.04   |
| LST2100SS    | 53         | 0.45   | LVHB050V      | 9          | 0.06   | M100PLG050      | 6, 47      | 0.04   |
| LST210SS     | 53, 91     | 0.48   | LVH075100MTLV | 9          | 0.135  | M100SWFSS       | 44         | 0.32   |
| LST216SS     | 53, 91     | 0.27   | LVHB075100MTV | 9          | 0.13   | M100SWP90       | 43         | 0.126  |
| LST220SS     | 5, 91      | N/A    | LVHB075MTV    | 9          | 0.13   | M100SWPG90      | 6, 43      | 0.13   |
| LST230SS     | 53, 91     | 0.49   | LVHB075V      | 9          | 0.118  | M100TEE         | 45         | 0.2    |
| LST250SS     | 53, 91     | 0.49   | LVPL025V      | 9          | 0.06   | M101CPG         | 6, 44      | 0.001  |
| LST280SS     | 53, 91     | 0.48   | LVPL038V      | 9          | 0.06   | M101G           | 49         | 0.006  |
| LST5100      | 87         | 0.016  | M100050FPT    | 46         | 0.06   | M101GSA         | 5, 44      | 0.07   |
| LST530       | 87         | 0.05   | M100050HBT    | 48         | 0.086  | M101TEE         | 45         | 0.23   |
| LST550       | 87         | 0.024  | M100075BRB    | 48         | 0.06   | M102G           | 49         | 0.01   |
| LST580       | 87         | 0.02   | M100075BRB90  | 48         | 0.06   | M12712          | 109, 111   | 3.372  |
| LSTM050-30   | 86         | 0.76   | M100075FPT    | 46         | 0.05   | M13712          | 115, 121   | 4.588  |
| LSTM050-30C  | 86         | 0.324  | M100075HBT    | 48         | 0.1    | M19712X         | 147, 149   | 27.046 |
| LSTM050-50   | 86         | 0.3    | M100075MPT    | 46         | 0.052  | M200100BRB      | 48         | 0.15   |
| LSTM050-50C  | 86         | 0.76   | M100100HBT    | 48         | 0.09   | M200100BRB90    | 48         | 0.16   |
| LSTM050-80   | 86         | 0.76   | M100125BRB    | 48         | 0.08   | M200100CPG      | 45         | 0.16   |
| LSTM050-80C  | 86         | 0.316  | M100125BRB90  | 48         | 0.11   | M200100TEE      | 45         | 0.525  |
| LSTM050B     | 87         | 0.103  | M100125BRB90  | 43         | 0.15   | M200125BRB      | 48         | 0.16   |
| LSTM050BC    | 87         | 0.12   | M100125HBT    | 5, 48      | 0.1366 | M200125BRB45    | 48         | 0.18   |
| LSTM050G     | 87         | 0.02   | M100125MPT    | 46         | 0.114  | M200125BRB90    | 48         | 0.21   |
| LSTM050H     | 87         | 0.176  | M100150BRB90  | 48         | 0.17   | M200125MPT      | 46         | 0.2    |
| LSTM075-30   | 86         | 0.76   | M100A         | 57         | 0.07   | M200125MPTSS    | 46         | 0.2    |
| LSTM075-30C  | 86         | 0.31   | M100BRB       | 48         | 0.066  | M200150BRB      | 48         | 0.17   |
| LSTM075-50   | 86         | 0.288  | M100BRB45     | 48         | 0.074  | M200150BRB45    | 48         | 0.17   |
| LSTM075-50C  | 86         | 0.308  | M100BRB90     | 48         | 0.08   | M200150BRB90    | 48         | 0.21   |
| LSTM075-80   | 86         | 0.76   | M100BRBSWP90  | 43         | 0.145  | M200150BRBSWP90 | 43         | 0.431  |
| LSTM075-80C  | 86         | 0.302  | M100BRBSWP90  | 6, 43      | 0.15   | M200150FPT      | 46         | 0.344  |
| LSTM075H     | 87         | 0.161  | M100CPG       | 44         | 0.09   | M200150MPT      | 46         | 0.23   |
| LV025MTV     | 9          | 0.06   | M100CPG025G   | 6, 44      | N/A    | M200150MPTSS    | 46         | 0.23   |
| LV025V       | 9          | 0.054  | M100CPG45     | 44         | 0.09   | M200300TEG075   | 6          | 0.661  |
| LV038050MTLV | 9          | 0.07   | M100CPG90     | 45         | 0.14   | M200A           | 57         | 0.24   |
| LV038050MTV  | 9          | 0.058  | M100CR        | 47         | 0.24   | M200BRB         | 48         | 0.24   |
| LV038MTV     | 9          | 0.07   | M100FPT       | 46         | 0.09   | M200BRB45       | 48         | 0.262  |
| LV038V       | 9          | 0.07   | M100G         | 49         | 0.02   | M200BRB90       | 48         | 0.34   |



# REFERENCE

| PART NO      | PAGE NO(S) | WEIGHT | PART NO       | PAGE NO(S) | WEIGHT | PART NO       | PAGE NO(S) | WEIGHT |
|--------------|------------|--------|---------------|------------|--------|---------------|------------|--------|
| M200CPG      | 44         | 0.43   | M220BRBWP90   | 43         | 0.399  | M300220SWP90  | 43         | 0.571  |
| M200CPG025G  | 6, 44      | N/A    | M220BWASS     | 46         | 0.5    | M300220WYCG   | 6,45       | 1.050  |
| M200CPG45    | 44         | 0.31   | M220CPG       | 44         | 0.21   | M300300HBT    | 48         | 1.034  |
| M200CPG90    | 45         | 0.626  | M220CPG2GISO  | 6, 44      | 0.15   | M300375SWFSS  | 44         | 3.2    |
| M200CPG90SH  | 45         | 0.423  | M220CPG3G     | 6, 44      | N/A    | M300400A      | 47, 124    | 0.712  |
| M200CR       | 47         | 0.692  | M220CPG45     | 41, 44     | 0.24   | M300400BRB    | 48, 124    | 0.728  |
| M200FPT      | 46         | 0.29   | M220CPG6      | 41, 44     | 0.375  | M300A         | 47         | 0.35   |
| M200MPT      | 46         | 0.26   | M220CPG6025G  | 6, 44      | N/A    | M300ASWP90    | 43         | 0.897  |
| M200MPTSS    | 46         | 0.81   | M220CPG90     | 45         | 0.341  | M300BRB       | 48         | 0.478  |
| M200PLG      | 47         | 0.12   | M220CR        | 47         | 0.578  | M300BRB45     | 48         | 0.518  |
| M200PLG025   | 6, 47      | 0.084  | M220D         | 47         | 0.73   | M300BRB90     | 48         | 0.798  |
| M200PLG038   | 6, 47      | 0.09   | M220FPT       | 46         | 0.26   | M300BRBWP90   | 43         | 1.184  |
| M200PLG050   | 6, 47      | 0.09   | M220MPT       | 46         | 0.21   | M300BRBWP90   | 6, 43      | 1.24   |
| M200PLG075   | 6, 47      | 0.1    | M220MPTSS     | 46         | 0.62   | M300CPG       | 44         | 0.417  |
| M200PLG100   | 6, 47      | 0.11   | M220MPTSWP90  | 43         | 0.331  | M300CPG12     | 6, 42      | 1.01   |
| M200SWFSS    | 44         | 0.68   | M220P6PRO     | 108, 109   | N/A    | M300CPG12G    | 6, 44      | N/A    |
| M200SWP90    | 43         | 0.365  | M220PH5       | 108, 109   | 55     | M300CPG2GISO  | 6, 44      | 0.279  |
| M200TEE      | 45         | 0.611  | M220PH5W      | 110        | 55     | M300CPG45     | 41, 44     | 0.518  |
| M200THB100   | 5          | 0.507  | M220PH6       | 108, 109   | 55     | M300CPG55G    | 6, 44      | 0.538  |
| M200YG45     | 6, 45      | 1.3    | M220PLG       | 47         | 0.12   | M300CPG7      | 41, 44     | 0.632  |
| M201CPG      | 6, 44      | 0.001  | M220PLG038    | 6, 47      | 0.1    | M300CPG7025G  | 6, 44      | N/A    |
| M201G        | 49         | 0.05   | M220PLG075    | 6, 47      | 0.11   | M300CPG90     | 45         | 0.745  |
| M201TEEV075  | 5          | N/A    | M220PO        | 106, 107   | 8.372  | M300CR        | 47         | 1.215  |
| M202G        | 49         | 0.025  | M220SWFSS     | 44         | 0.58   | M300FPT       | 46         | 0.514  |
| M220100BRB   | 48         | 0.15   | M220SWP038G90 | 6          | N/A    | M300MPT       | 46         | 0.437  |
| M220100CPG   | 45         | 0.15   | M220SWP050G90 | 6          | 0.292  | M300MPTSS     | 46         | 1.85   |
| M220100TEE   | 45         | 0.403  | M220SWP90     | 5, 43      | 0.286  | M300MPTSWP90  | 43         | 0.833  |
| M220125BRB   | 48         | 0.16   | M220SWPG90    | 5, 43      | N/A    | M300P11PRO    | 114, 115   | 61.988 |
| M220150BRB   | 48         | 0.16   | M220TEE       | 45         | 0.522  | M300PB        | 114, 115   | 21.35  |
| M220150BRB90 | 48         | 0.211  | M220Y45       | 41, 45     | 1.316  | M300PH6       | 114, 115   | 45.4   |
| M220150HBT   | 5, 48      | 0.275  | M220YG45      | 6, 47, 45  | 1.34   | M300PH6W      | 120        | 49     |
| M220150MPTSS | 46         | 0.65   | M221CPG       | 6, 44      | N/A    | M300PLG       | 47         | 0.25   |
| M220200CPG   | 45         | 0.2    | M221CPG6      | 6, 44      | N/A    | M300PLG075    | 6, 47      | 0.23   |
| M220200HBT   | 48         | 0.39   | M221G         | 41, 49     | 0.03   | M300PLG100    | 6, 47      | 0.248  |
| M220200SWP90 | 43         | 0.356  | M221GSA       | 44         | 0.258  | M300PO        | 114, 115   | 9.792  |
| M220200TEE   | 45         | 0.567  | M221SWP90     | 5, 6, 43   | N/A    | M300POW6      | 120        | 16.24  |
| M220375SWFSS | 44         | 1.35   | M222G         | 49         | 0.03   | M300SWFSS     | 44         | 1.46   |
| M220A        | 47         | 0.2    | M300200CPG    | 45         | 0.267  | M300SWP050G90 | 6          | 0.699  |
| M220ASWP90   | 43         | 0.399  | M300220BRB    | 48         | 0.284  | M300SWP90     | 43         | 0.675  |
| M220BRB      | 48         | 0.19   | M300220BRB90  | 48         | 0.406  | M300SWPG90    | 6, 43      | 0.75   |
| M220BRB45    | 48         | 0.225  | M300220CPG    | 41, 45     | 0.245  | M300TEE       | 45         | 1.111  |
| M220BRB90    | 48         | 0.309  | M300220MPTSS  | 46         | 1.332  | M300Y45       | 41, 45     | 3.32   |

# REFERENCE

| PART NO     | PAGE NO(S) | WEIGHT | PART NO    | PAGE NO(S) | WEIGHT | PART NO     | PAGE NO(S) | WEIGHT |
|-------------|------------|--------|------------|------------|--------|-------------|------------|--------|
| M300YG45    | 6, 41, 45  | 3.258  | MEVX1014   | 33         | 19.485 | MLS2100SS   | 53         | 0.54   |
| M301CPG7    | 6, 44      | N/A    | MEVX102    | 33         | 9.073  | MLS220C1    | 53         | 0.82   |
| M301G       | 41, 49     | 0.03   | MEVX103    | 33         | 14.47  | MLS220G1    | 53         | 0.008  |
| M301GSA     | 44         | 0.55   | MEVX200    | 30         | 4.22   | MLS220R1    | 53         | 0.417  |
| M302G       | 49         | 0.05   | MEVX200BL  | 32         | 5.751  | MLS222-04   | 52         | 3.82   |
| M303D       | 47         | 1.5    | MEVX200SL  | 32         | 7.018  | MLS222-10   | 52         | 3.5    |
| M305PHYW    | 120        | 26.4   | MEVX201    | 30         | 4.775  | MLS222-16   | 52         | 3.7    |
| M332PIE101W | 146        | 270    | MEVX220BL  | 32         | 6.98   | MLS222-30   | 52         | 3.75   |
| M332PIE10W  | 146        | N/A    | MEVX220SL  | 32         | N/A    | MLS222-50   | 52         | 3.75   |
| M332PIH13W  | 146        | 155    | MEVX221    | 30         | 4.775  | MLS222-80   | 52         | 3.7    |
| M332PIHAW   | 148        | 68.592 | MEVX300    | 31         | 8.98   | MLS222B     | 53         | 2.2    |
| M332PIHYW   | 148        | 190    | MEVX300BL  | 32         | 18.28  | MLS222BC    | 53         | 3.25   |
| M332POIW    | 146        | 70.532 | MEVXR100   | 29         | 2.491  | MLS250SS    | 53         | 0.6    |
| M350PBW     | 124        | 34.1   | MEVXR100SL | 32         | 4.7    | MLS280SS    | 53         | 0.57   |
| M350PE15W   | 123        | 131.3  | MEVXR101   | 29         | 3.82   | MLS300-12   | 52         | 8      |
| M350PEOW    | 123        | 17.1   | MEVXR200   | 30         | 2.882  | MLS300-20   | 52         | 8      |
| M350PH13W   | 123        | 88.2   | MEVXR200SL | 32         | 3.979  | MLS300-20V  | 52         | N/A    |
| M350PHAW    | 124        | 33.5   | MEVXR220   | 30         | 3.405  | MLS300-50   | 52         | 8.44   |
| M350PHYW    | 123        | 40.9   | MEVXR220SL | 32         | 6.627  | MLS300B     | 53         | 5.01   |
| M350POW     | 123        | 17.1   | MEVXR300   | 31         | 8.98   | MLS300B1    | 97         | 5.357  |
| M350PVAN14W | 123        | 102    | MFM100     | 42         | 2.75   | MLS300BC    | 53         | 7.48   |
| MBF100      | 54,160     | 0.9    | MFM220     | 42         | 2.75   | MLS300CAP   | 53, 97     | 1.36   |
| MBF100BD    | 54,160     | 0.948  | MFM300     | 41         | 5.4    | MLS300CEG   | 53, 97     | 0.024  |
| MBF200      | 54,160     | 1.37   | MHV200     | 40         | 0.57   | MLS300ECGV  | 53, 97     | 0.04   |
| MBF200BD    | 54,160     | 1.44   | MHV220A    | 40, 41     | 0.8    | MLS300G     | 53, 97     | 0.03   |
| MBF220      | 54,160     | 1.62   | MIS220     | 41         | 10.175 | MLST100-100 | 50         | 0.75   |
| MBF220BD    | 54,160     | 1.62   | MIS300     | 41         | 23.06  | MLST100-30  | 50         | 0.75   |
| MBF300      | 54,160     | 2.34   | MLEV100    | 33         | 0.65   | MLST100-50  | 50         | 0.75   |
| MBF300BD    | 54,160     | 2.5    | MLEV100A   | 33         | 1.13   | MLST100-80  | 50         | 0.75   |
| MBP200      | 67         | 0.26   | MLEV100C   | 33         | 1.155  | MLST100-H   | 51         | 0.467  |
| MCV100      | 44         | 0.154  | MLS100-80  | 50         | 0.88   | MLST100-HB  | 51         | 0.63   |
| MCV100V     | 5, 44      | 0.153  | MLS100B    | 51         | 0.646  | MLST150-100 | 50         | 2      |
| MCV200      | 44         | 0.45   | MLS100BC   | 51         | 0.896  | MLST150-30  | 50         | 2      |
| MCV221      | 44         | 0.5    | MLS200-06  | 46         | 2.25   | MLST150-50  | 50         | 2      |
| MCV300      | 44         | 1.224  | MLS200-12  | 50         | 2.5    | MLST150-80  | 50         | 2      |
| MCV301      | 44         | 1.26   | MLS200-20  | 50         | 2.15   | MLST150-80V | 50         | 2.125  |
| MEVX100     | 29         | 3.82   | MLS200-30  | 46         | 2.15   | MLST150-H   | 51         | 1.292  |
| MEVX100BL   | 32         | 4.7    | MLS200-50  | 50         | 3.9    | MLST150-HB  | 51         | 1.75   |
| MEVX100SL   | 32         | 4.7    | MLS200-80  | 50         | 2.15   | MLSTM100-80 | 5, 49      | 0.34   |
| MEVX101     | 29         | 4.24   | MLS200B    | 41         | 1.526  | MLSTM100HB  | 5, 49      | 0.34   |
| MEVX1012    | 33         | 9.6    | MLS200BC   | 51         | 2.07   | MLSTM100HBC | 5, 49      | 0.34   |
| MEVX1013    | 33         | 14.548 | MLS200BCM  | 50         | 2.315  | MPRV100-050 | 39         | 1.506  |

| PART NO      | PAGE NO(S) | WEIGHT | PART NO    | PAGE NO(S) | WEIGHT | PART NO   | PAGE NO(S) | WEIGHT |
|--------------|------------|--------|------------|------------|--------|-----------|------------|--------|
| MPRV100-075  | 39         | 1.45   | NIP100-SH  | 81         | 0.038  | RB100-075 | 81         | 0.04   |
| MPRV100-100  | 39         | 1.5    | NIP125-4   | 81         | 0.136  | RB125-038 | 5, 81      | 0.1    |
| MPRV100-125  | 39         | 1.54   | NIP125-6   | 81         | 0.22   | RB125-075 | 81         | 0.09   |
| MSUV100FP    | 18         | 0.46   | NIP125-SH  | 81         | 0.06   | RB125-100 | 81         | 0.06   |
| MSW220       | 44         | 0.4    | NIP150-3   | 81         | 0.14   | RB150-075 | 81         | 0.12   |
| MTF100BD     | 5, 54      | 0.42   | NIP150-4   | 81         | 0.22   | RB150-100 | 81         | 0.1    |
| MTF220BD     | 54         | 0.75   | NIP150-5   | 81         | 0.26   | RB150-125 | 81         | 0.1    |
| MTF300BD     | 54         | 2.092  | NIP150-6   | 81         | 0.34   | RB200-075 | 81         | 0.18   |
| MV100BL      | 12, 38     | 1.2    | NIP150-SH  | 81         | 0.12   | RB200-100 | 79         | 0.17   |
| MV100CF      | 5, 12, 34  | 0.75   | NIP200-4   | 81         | 0.25   | RB200-125 | 81         | 0.14   |
| MV100SL      | 38         | 1.13   | NIP200-6   | 81         | 0.38   | RB200-150 | 81         | 0.12   |
| MV200BL      | 13, 38     | 2      | NIP200-SH  | 81         | 0.14   | RB300-150 | 81         | 0.415  |
| MV200CF      | 34         | 2.024  | NIP2101    | 67         | 0.3    | RB300-200 | 81         | 0.359  |
| MV200SL      | 38         | 2      | NIP300-4   | 81         | 0.434  | RB400-300 | 81         | 1.032  |
| MV220BL      | 13, 38     | 4.63   | NIP300-6   | 81         | 0.696  | RC100-075 | 81         | 0.15   |
| MV220CF      | 34         | 2.798  | NIP300-SH  | 81         | 0.307  | RC150-100 | 81         | 0.2    |
| MV220SL      | 38         | 2.75   | NIP400-SH  | 5, 81      | 1.558  | RC150-125 | 81         | 0.206  |
| MV225CF      | 34         | 7.3    | PLUG025    | 82         | 0.03   | RC200-050 | 81         | 0.28   |
| MV300        | 34         | 3.9    | PLUG038    | 82         | 0.02   | RC200-100 | 81         | 0.26   |
| MV300BL      | 38         | 6.68   | PLUG050    | 82         | 0.02   | RC200-125 | 81         | 0.26   |
| MV300CF      | 34         | 5.866  | PLUG075    | 41, 82     | 0.04   | RC200-150 | 81         | 0.26   |
| MV301CF      | 41         | 6      | PLUG100    | 82         | 0.06   | RC300-200 | 81         | 0.624  |
| MVS220CF     | 35, 41     | 1.744  | PLUG125    | 82         | 0.09   | RN050-038 | 81         | 0.018  |
| MVS220FP     | 35         | 1.804  | PLUG150    | 82         | 0.1    | RN075-050 | 81         | 0.03   |
| MVS300CF     | 5, 36      | 3.046  | PLUG200    | 82         | 0.152  | RN100-050 | 81         | 0.06   |
| MVS300CFFP   | 36         | 3.75   | PLUG300    | 82         | 0.445  | RN100-075 | 81         | 0.06   |
| MVS300HSFP   | 37         | 6.32   | PV075      | 19         | 0.53   | RN125-075 | 81         | 0.086  |
| MVSF220FP    | 35         | 1.78   | PV100      | 19         | 0.52   | RN125-100 | 81         | 0.08   |
| MVSF300      | 36         | 3.29   | PV100-075  | 19         | 0.64   | RN150-100 | 81         | 0.122  |
| MVSF300FP    | 36         | 4      | PV100-075V | 19         | 0.35   | RN150-125 | 81         | 0.14   |
| MVSMT220FP   | 35         | 1.75   | PV10265    | 19         | 0.07   | RN200-125 | 81         | 0.16   |
| MVSMT300     | 36         | 3.192  | PV10265V   | 19         | 0.2    | RN200-150 | 81         | 0.17   |
| MVSMT300HSFP | 37         | 6.44   | RB038-025  | 81         | 0.01   | RN300-200 | 81         | 0.365  |
| NIP025-SH    | 81         | 0.01   | RB050-018  | 5, 81      | 0.02   | RS21      | 85         | 0.756  |
| NIP038-SH    | 81         | 0.02   | RB050-025  | 81         | 0.02   | RSTB      | 85         | 0.704  |
| NIP050-3     | 81         | 0.04   | RB050-038  | 81         | 0.01   | SL025-90  | 83         | 0.02   |
| NIP050-SH    | 81         | 0.02   | RB075-025  | 81         | 0.04   | SL038-90  | 83         | 0.03   |
| NIP075-4     | 81         | 0.074  | RB075-038  | 81         | 0.03   | SL050-90  | 83         | 0.06   |
| NIP075-6     | 81         | 0.12   | RB075-050  | 81         | 0.03   | SL075-45  | 83         | 0.07   |
| NIP075-SH    | 81         | 0.03   | RB100-018  | 5, 81      | 0.60   | SL075-90  | 83         | 0.08   |
| NIP100-4     | 81         | 0.09   | RB100-025  | 81         | 0.07   | SL100-45  | 83         | 0.1    |
| NIP100-6     | 81         | 0.14   | RB100-050  | 81         | 0.05   | SL100-90  | 83         | 0.13   |

| PART NO  | PAGE NO(S) | WEIGHT | PART NO | PAGE NO(S) | WEIGHT | PART NO   | PAGE NO(S)  | WEIGHT |
|----------|------------|--------|---------|------------|--------|-----------|---|--------|
| SL125-45 | 83         | 0.14   | TEE075  | 82         | 0.14   | TL652E    | 68  | 0.64   |
| SL125-90 | 83         | 0.14   | TEE100  | 82         | 0.21   | TL652S    | 68  | 0.63   |
| SL150-45 | 83         | 0.22   | TEE125  | 82         | 0.32   | TL6531    | 69  | 0.084  |
| SL150-90 | 83         | 0.25   | TEE150  | 83         | 0.445  | TLVA10    | 68  | 2.25   |
| SL200-45 | 83         | 0.34   | TEE200  | 83         | 0.584  | TM075/050 | 6, 85   | 0.16   |
| SL200-90 | 83         | 0.41   | TEE300  | 83         | 1.594  | UB100     | 45  | 0.24   |
| SL300-45 | 83         | 0.833  | TEG075  | 6, 83      | 0.14   | UB202     | 45  | 0.26   |
| SL300-90 | 83         | 1.054  | TEG100  | 6, 83      | 0.22   | UB220     | 45  | 0.32   |
| ST200    | 68         | 0.809  | TF038SS | 72         | 0.25   | UV050FP   | 18  | 0.25   |
| ST300    | 68         | 1.332  | TF050   | 72         | 0.25   | UV075FP   | 18  | 0.25   |
| SUV050FP | 18         | 0.25   | TF050SS | 72         | 0.8    | UV100FP   | 18  | 0.37   |
| SUV075FP | 18         | 0.4    | TF075   | 72         | 0.2    | UV125FP   | 18  | 1      |
| SUV100FP | 18         | 0.4    | TF075SS | 72         | 1.15   | UV150FP   | 18  | 1      |
| SUV125FP | 18         | 0.88   | TF075V  | 72         | 0.22   | UV15163   | 51, 89, 93, 101, 103, 105, 107, 111, 119, 121, 125, 127, 129, 131, 133, 139, 141, 143, 147, 149, 153, 155, 157, 159 | 0.002  |
| SUV150FP | 18         | 0.88   | TF100   | 72         | 0.35   | UV15163V  | 93, 101, 105, 119, 153, 155, 157, 159   | 0.002  |
| SUV200FP | 18         | 1.45   | TF100AV | 73         | 0.44   | UV200FP   | 18  | 1.5    |
| SW100    | 85         | 0.16   | TF100G  | 5, 72      | 0.02   | UV204FFPD | 67  | 1.58   |
| SW150    | 85         | 0.36   | TF100GV | 5, 72      | 0.035  | V050      | 10  | 0.75   |
| SW220    | 85         | 0.52   | TF100SS | 72         | 2.85   | V07018    | 101, 103, 105, 107, 109, 111, 113, 115, 117, 119, 121, 125  | 0.1    |
| TA283    | 69         | 0.2    | TF125   | 72         | 0.35   | V07019    | 101, 103, 105, 107, 109, 111, 113, 115, 117, 119, 121, 125  | 0.008  |
| TA283QD  | 69         | 0.3    | TF125AV | 73         | 0.386  | V075      | 10  | 0.75   |
| TC120    | 80         | 0.1    | TF125SS | 72         | 1.92   | V075BL    | 16  | 1.35   |
| TC130    | 80         | 0.1    | TF138GV | 72         | 0.1    | V075SL    | 16  | 1.35   |
| TC150    | 80         | 0.11   | TF150   | 72         | 0.63   | V100      | 10  | 0.682  |
| TC162    | 80         | 0.12   | TF150AV | 73         | 0.68   | V100BL    | 13, 16  | 1.25   |
| TC181    | 80         | 0.14   | TF150SS | 72         | 4.88   | V100FP    | 10  | 1.16   |
| TC193    | 80         | 0.12   | TF200   | 72         | 0.55   | V100SL    | 16  | 1.31   |
| TC206    | 80         | 0.14   | TF200AV | 73         | 0.596  | V10117    | 149   | 0.1    |
| TC218    | 80         | 0.13   | TF200SS | 72         | 3.6    | V10118    | 125, 127, 129, 131, 133, 135, 137, 147, 149, 153, 155, 157, 159   | 0.004  |
| TC224    | 80         | 0.14   | TF200V  | 72         | 0.56   | V10119    | 105, 125, 127, 129, 131, 133, 135, 147, 153, 155, 157, 159  | 0.1    |
| TC231    | 80         | 0.15   | TF220   | 72         | 0.82   | V10153138 | 12  | 0.07   |
| TC250    | 80         | 0.16   | TF220G  | 72         | 0.038  | V10161    | 17  | 0.176  |
| TC287    | 80         | 0.17   | TF220SS | 72         | 5.27   | V10200    | 5, 10, 2, 34  | 0.143  |
| TC312    | 80         | 0.16   | TF300   | 72         | 2      | V10264    | 151   | 0.002  |
| TC331    | 80         | 0.17   | TF300G  | 72         | 0.094  | V10270    | 12  | 0.138  |
| TC343    | 80         | 0.17   | TF300SS | 72         | 7.9    | V10271    | 12  | 0.14   |
| TC425    | 80         | 0.18   | TF400   | 72         | 4.5    | V125      | 10  | 1.25   |
| TC438    | 80         | 0.36   | TF400G  | 72         | 0.7    | V125BL    | 13, 16  | 2.126  |
| TC456    | 80         | 0.38   | TF400GV | 72         | 0.752  | V125FP    | 10  | 1.91   |
| TEE025   | 82         | 0.02   | TL600C  | 68         | 0.46   | V125SL    | 16  | 2.07   |
| TEE038   | 82         | 0.05   | TL650S  | 68         | 0.5    | V150      | 10  | 1.87   |
| TEE050   | 82         | 0.1    | TL651S  | 68         | 0.7    | V150BL    | 13, 16  | 2      |



# REFERENCE

| PART NO    | PAGE NO(S)  | WEIGHT | PART NO      | PAGE NO(S) | WEIGHT |
|------------|---|--------|--------------|------------|--------|
| V150SL     | 16  | 2      | VSF200       | 13         | 1.25   |
| V200       | 10  | 1.88   | VSF200CF     | 35         | 1.49   |
| V20018     | 105, 107, 117, 125, 131, 133, 137, 139, 141, 143, 145, 151, 155, 157, 159 | 0.004  | VSF200FFAF   | 11         | 3.05   |
| V20019     | 137, 139, 141, 143, 159   | 0.016  | VSF204FP     | 14         | 1.82   |
| V200BL     | 13, 16  | 2.8    | VSF300       | 15         | 3.424  |
| V200FP     | 5, 11, 12   | 3.25   | VSFHB200     | 13         | 1.52   |
| V200SL     | 16  | 2.75   | VSFMT200     | 13         | 1.562  |
| V20153138  | 12  | 0.176  | VSFMT204FP   | 14         | 1.862  |
| V20207     | 69, 78  | 0.006  | VSFMT204HSFP | 14         | 2.95   |
| V204FP     | 10  | 2.74   | VSFMT300     | 15         | 3.374  |
| V20200     | 5, 10, 17, 34   | 0.206  | VSFMT300FP   | 15         | 4.29   |
| V20353TS   | 5, 17   | 0.002  | VSFMT300HSFP | 15         | 6.63   |
| V25153138  | 12  | 0.16   | VSMT200      | 13         | 1.35   |
| V25200     | 5, 10, 11, 17, 34   | 0.577  | VSMT200CF    | 35         | 1.432  |
| V25200BL   | 5, 16, 38   | N/A    | VSMT204FP    | 14         | 1.874  |
| V25270     | 12  | 0.194  | VSMT300      | 15         | 3.27   |
| V25271     | 12  | 0.356  | VSS025       | 19         | 0.634  |
| V300       | 5, 11, 12   | 3.75   | VSS038       | 19         | 0.59   |
| V300FP     | 5, 11, 12   | 5.67   | VSS050       | 19         | 0.7    |
| V30200     | 5, 11, 34   | N/A    | VSS075       | 19         | 1.298  |
| V35200     | 5, 11, 34   | 1.52   | VSS100       | 19         | 2.094  |
| V400       | 5, 11, 12   | 8.5    | VSS150       | 19         | 3.996  |
| V40200     | 5, 11   | 4.2    | VSS200       | 19         | 6.808  |
| VA150      | 17  | 2.592  | VSS300       | 19         | 18.43  |
| VA200      | 17  | 2.8    | W230237      | 66         | 1.07   |
| VA200/150  | 5, 17   | 4.62   | W230238      | 66         | 1.17   |
| VA200FP    | 17  | 3.958  | W230239      | 66         | 1.07   |
| VC200      | 73  | 0.219  | W230240      | 66         | 1.1    |
| VC230      | 73  | 0.26   | WSF210FSA    | 66         | 1.2    |
| VC300      | 73  | 0.54   | WSF210FSAV   | 66         | 1      |
| VC330      | 73  | 0.68   | WSMT210FSA   | 66         | 1.07   |
| VFMT200FP  | 5, 11, 12   | 3.368  | WSMT210FSAV  | 66         | 1      |
| VFMT204FP  | 10  | 3.33   |              |            |        |
| VL20153    | 12  | 0.35   |              |            |        |
| VL25153    | 12  | 0.41   |              |            |        |
| VN100      | 17  | 0.712  |              |            |        |
| VS204FP    | 14  | 1.834  |              |            |        |
| VS30200    | 5, 15, 36   | 0.622  |              |            |        |
| VSBHB204FP | 8   | 2.675  |              |            |        |
| VSBHB205FP | 8   | 2.965  |              |            |        |
| VSBHB304FP | 8   | 5.1    |              |            |        |
| VSBHB305FP | 8   | 5.52   |              |            |        |



**THE #ORIGINALYELLOWHANDLE**



**BANJO CORPORATION**  
 A Unit of IDEX Corporation  
 150 Banjo Drive  
 Crawfordsville, IN 47933 U.S.A.  
 Telephone: (765) 362-7367  
 Fax: (765) 362-0744  
 banjocorp.com  
 #OriginalYellowHandle



Follow us on:

Scan to visit  
 BanjoCorp.com